

**Introduction**

The flexible cable duct average temperature thermostat incorporates numerous precision thermistor temperature sensors and provides a Form C relay output (NO/NC) with an adjustable setpoint. The sensors are encapsulated at equal distances along the cable assembly and is available in various lengths. All probes provide excellent heat transfer, fast response and resist moisture penetration. Two enclosure styles are available.

**Before Installation**

Read these instructions carefully before installing and commissioning the temperature thermostat. Failure to follow these instructions may result in product damage. Do not use in an explosive or hazardous environment, with combustible or flammable gases, as a safety or emergency stop device or in any other application where failure of the product could result in personal injury. **Take electrostatic discharge precautions during installation and do not exceed the device ratings.**

**Mounting (Enclosure A)**

The duct average sensor installs directly into any air duct with several lengths available for a wide range of duct sizes. Select a suitable installation area in the middle of the duct wall. To achieve the best reading, do not place in an area where air stratification may be present. **Mount the sensor at least 1.5 m (5') in either direction from elbows, dampers, filters or other duct restrictions. Avoid areas where the sensor is exposed to vibrations or rapid temperature changes.**

Once a suitable spot is selected, drill a 9.5 - 12 mm (3/8" - 1/2") hole.

Uncoil the wire probe and slide into the drilled hole until the enclosure is flush against the duct. The airflow direction is not important. Secure the enclosure to the duct with #10 x 25 mm (1") self tapping screws (not provided). Tighten screws until the enclosure is tight against the duct and that there is no movement of the enclosure as shown in Figure 1.

A foam gasket is provided on the back of the enclosure that provides a tight seal against any air leaks.

The probe can easily shaped to fit any duct size but observe a minimum bend radius of 4" to prevent damage to the wire or sensors. Criss-cross the duct multiple times so that the probe covers a large section of the duct. The probe needs to be fastened onto hangers using tube clamps or wire ties. See Figure 2.

Using a Phillips screwdriver, remove the (2) screws, as shown in Figure 3.

Remove cover and set aside with screws for re-installing after wiring and set up.

Two 21 mm (0.8125") holes are provided for connection of either 12.77mm (0.5") EMT or a cable gland style connector as shown in Figure 4. Insert the EMT or cable gland connector through the hole and securely fasten using a locknut. If only one connection hole is required, use the included hole cap to cap off the unused one as shown in Figure 5. **Special care must be taken not to damage any internal components during installation.**

Make wire connections as per the "Wiring" illustrations on Page 2.

Once wiring and set up are complete, re-install cover and tighten the (2) screws using a Phillips screwdriver.

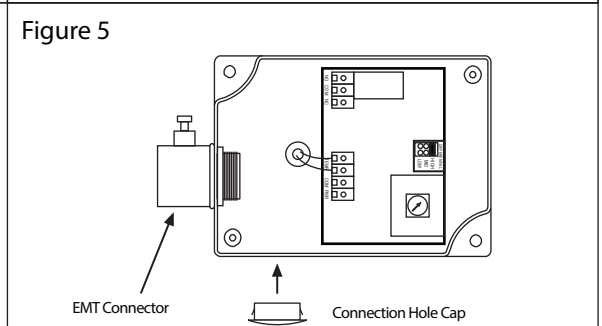
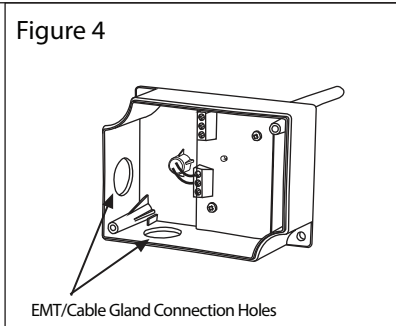
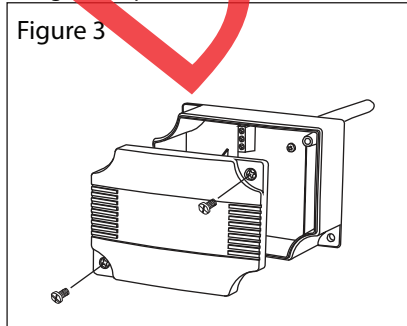
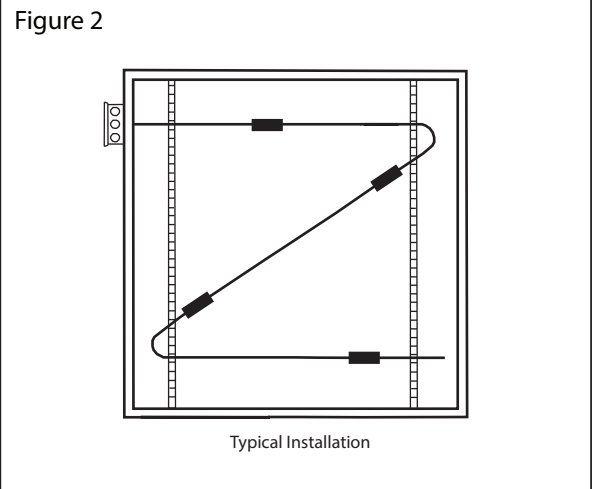
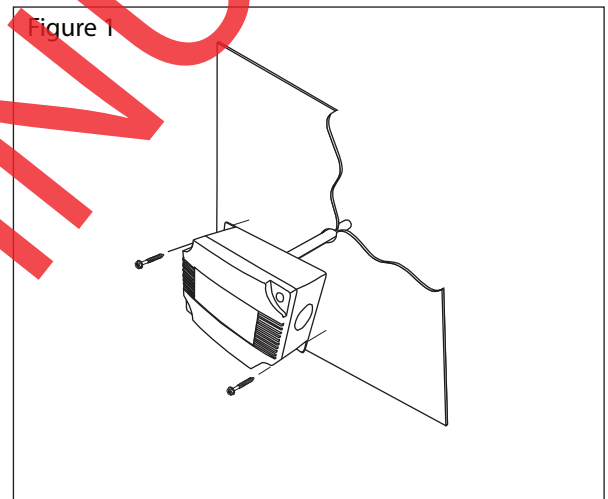

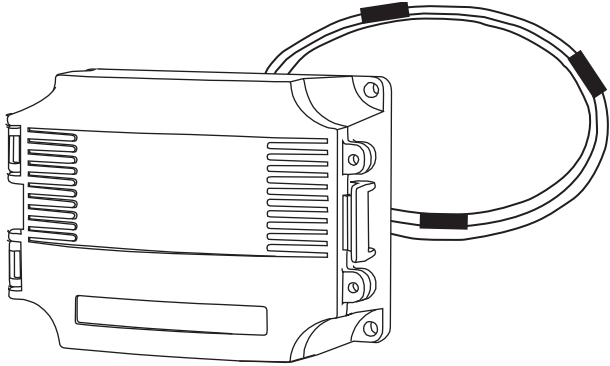

### Mounting (Enclosure D)

The sensor installs directly into any air duct with several lengths available for a wide range of duct widths/diameters. Select a suitable installation area in the middle of the duct wall. To achieve the best reading, do not place in an area where air stratification may be present. **Mount the sensor at least 1.5 m (5') in either direction from elbows, dampers, filters or other duct restrictions. Avoid areas where the sensor is exposed to vibrations or rapid temperature changes.**

Once a suitable spot is selected, drill a 9.5 - 12 mm (3/8" - 1/2") hole.

Uncoil the wire probe and slide into the drilled hole until the enclosure is flush against the duct. The airflow direction is not important. Secure the enclosure to the duct with #10 x 25 mm (1") self tapping screws (not provided). Tighten screws until the enclosure is tight against the duct and that there is no movement of the enclosure as shown in Figure 6.

A foam gasket is provided on the back of the enclosure that provides a tight seal against any air leaks.

The probe can easily be shaped to fit any duct size but observe a minimum bend radius of 4" to prevent damage to the wire or sensors. Criss-cross the duct multiple times so that the probe covers a large section of the duct. The probe needs to be fastened onto hangers using tube clamps or wire ties. See Figure 7.

The enclosure has a hinged cover with latch. Open cover by pulling slightly on the latch on the right side of the enclosure. At the same time pulling on the cover, as illustrated in Figure 8.

Feed conduit through the provided hole in bottom of enclosure and secure with a lock nut as shown in Figure 9. It is recommended that weatherproof conduit or cable gland fittings be used.

Make wiring connections as per the "Wiring" illustrations on Page 2.

Swing door closed until securely latched. For added security, 2 screws are provided that may be installed in the integrated screw tabs. See Figure 10.

Figure 6

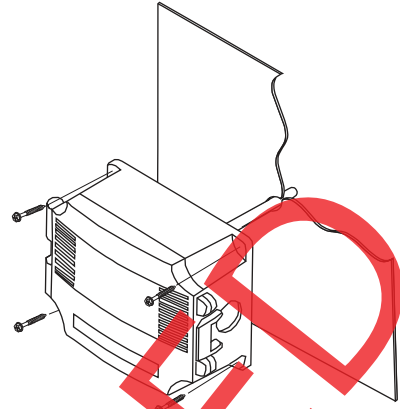
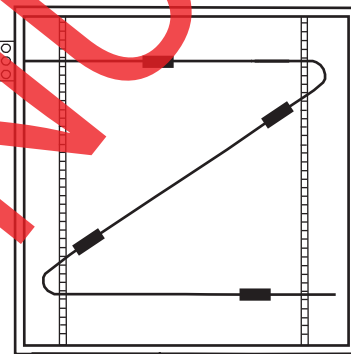

Figure 7



Typical Installation

Figure 8

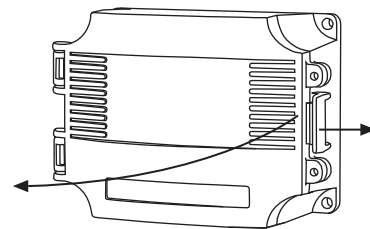
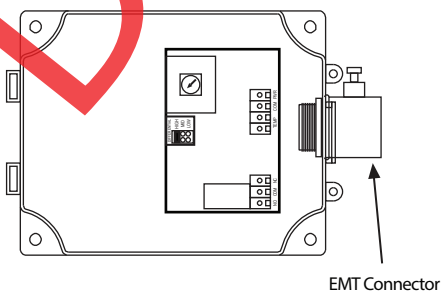
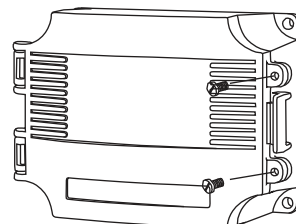

Figure 9



EMT Connector

Figure 10



## Wiring

- Deactivate the 24 Vac/dc power supply until all connections are made to the device to prevent electrical shock or equipment damage.
- Use 14-22 AWG shielded wiring for all connections and do not locate the device wires in the same conduit with wiring used to supply inductive loads such as motors. Make all connections in accordance with national and local codes.
- The temperature thermostat comes with the temperature sensor pre-wired to the PCB. If removal is required for installation then it may be re-wired as shown in Figure 11.
- Pull at least six inches of control wire into the enclosure, then complete the wiring connection according to the wire diagram for the applicable power supply as shown in Figure 12.
- Connect the DC positive or the AC voltage hot side to the PWR terminal. The supply common is connected to the COM terminal. See Figure 12.
- The relay has both Normally Open (NO) and Normally Closed (NC) contacts available. The relay output is available on the NO/COM/NC terminal. Make connections before applying power as shown in Figure 13.
- The setpoint differential has 3 jumper selectable settings (Low/Mid/High) Set jumper to desired differential as shown in Figure 14.
- To set the switching setpoint, turn the setpoint potentiometer to the desired temperature setting as shown in Figure 15.
- Once all connections settings are made and checked, power can be applied.

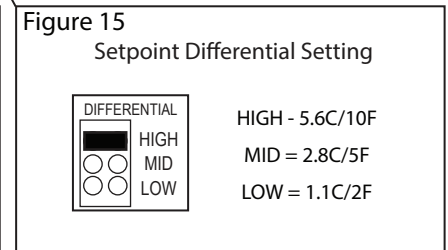
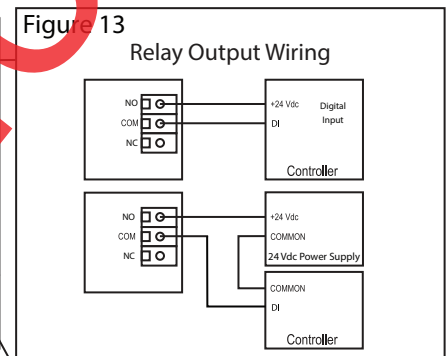
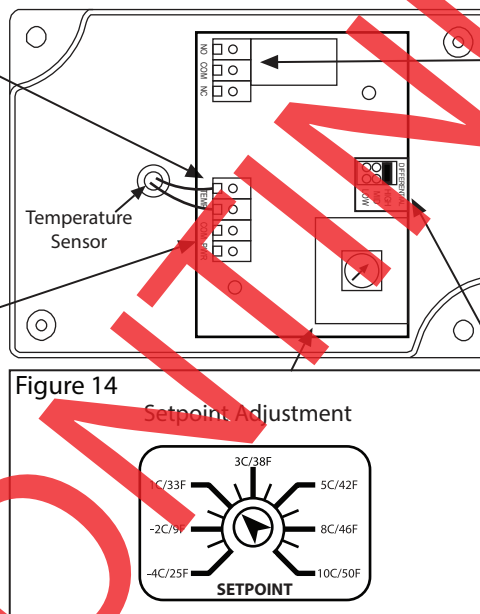
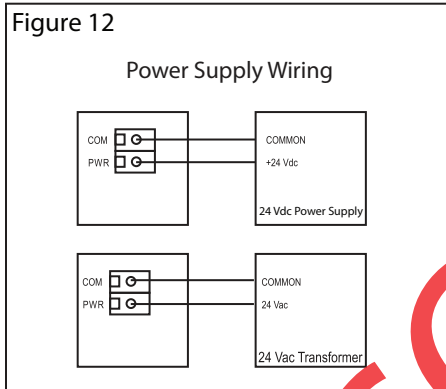
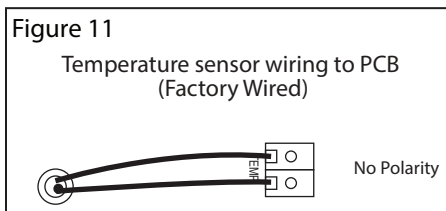

## Specification:

Power Supply	12 to 28 Vac/dc
Consumption	50 mA max
Relay Contacts	SPDT, Form C contacts (N.O. and N.C.) 5 Amps @ 30 Vdc/250 Vac resistive 1.5 Amps @ 30 Vdc/250 Vac inductive
Relay Action	Activates on temperature fall
Setpoint Operation	Single-turn knob-pot on pcb
Adjustable Setpoint	4 to 16°C (25 to 50°F)
Setpoint Temperature	Low/Mid/High jumper selectable
Differential	1.1/2.8/5.6 °C (2/5/10 °F)
Temperature Sensor	10K ohm curve matched precision thermistor
Sensor Accuracy	±0.2°C, 0 to 70°C (±0.36°F, 32 to 158°F)

Probe Sensing Range	-20 to 60 °C (-4 to 140 °F)
Probe Lengths	1800, 3600, 6100 or 7300 mm (6, 12', 20' or 24')
Probe/Wire Material	FT-6 Plenum-rated
Operating Conditions	-10 to 50°C (14 to 122°F), 5 to 95% RH non-condensing
Storage Conditions	-30 to 70°C (-22 to 158°F), 5 to 95%RH, non-condensing
Enclosure	(A) ABS, UL94-5VB, IP61 (NEMA 2) (D)-ABS, UL94-5VB, IP65 (NEMA 4X)
Wiring Connections	Screw terminal block (14 to 22 AWG)

**Dimensions:**

**Enclosure A**

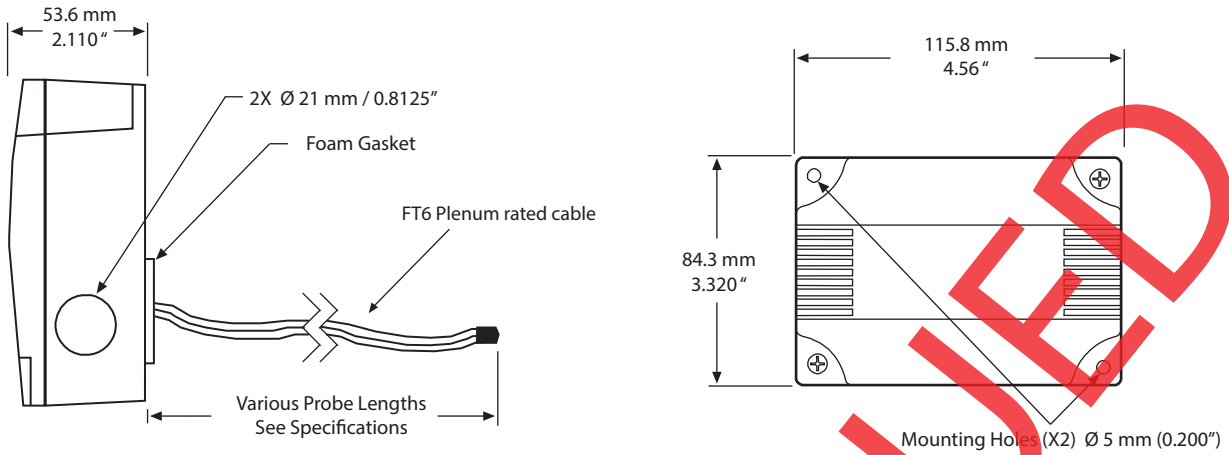

**Enclosure D**

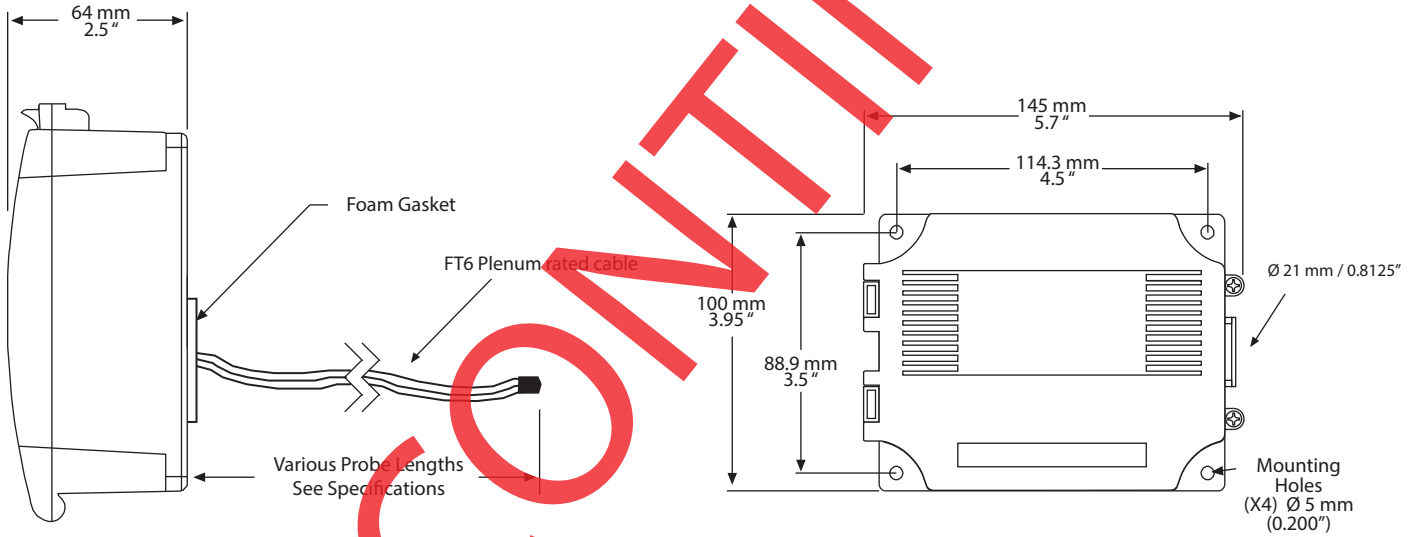

DISCONTINUED