

INTRODUCTION

The single point flying lead temperature thermostat utilizes a precision sensor that is encapsulated in a 50 mm (2") long x 6 mm (0.236") diameter OD, 304 series stainless steel probe and is provided with 3.05 m (10') of plenum rated FT-6 cable. All probes provide excellent heat transfer, fast response and resistance to moisture penetration. A Polycarbonate enclosure with a hinged and gasketed cover is provided for ease of installation.

BEFORE INSTALLATION

Read these instructions carefully before installing and commissioning the temperature sensor. Failure to follow these instructions may result in product damage. Do not use in an explosive or hazardous environment, with combustible or flammable gases, as a safety or emergency stop device or in any other application where failure of the product could result in personal injury. **Do not exceed the device ratings.**

MOUNTING

The flying lead sensor can be used in several different types of applications where single point temperature monitoring is required.

Listed below are some typical applications

The flying lead sensor can be installed directly into any air duct. Select a suitable installation area in the middle of the duct. To achieve the best reading, do not place in an area where air stratification may be present. Avoid areas where the sensor is exposed to vibrations or rapid temperature changes.

Once a suitable spot is selected, drill a 3/8" hole in the top of the duct and slide the probe through, mount a length of flexible duct hanger from top to bottom of the duct. Mount the probe to the duct hanger using a tube clamp or wire tie. See Figure 1.

The flying lead could also be used to measure pipe temperature. Select a suitable spot along the pipe, remove a small section of insulation if present and set aside. It is recommended that thermal compound be used to improve heat transfer. Spread a liberal amount on the pipe. Lay probe in thermal compound and secure sensor to pipe using a worm gear clamp (not included).

For added protection it is recommended to wrap the probe cable around the pipe 1-2 times. Re-install insulation if present, allowing sensor cable to protrude. See Figure 2.

The enclosure has a hinged cover with latch. Open cover by pulling slightly on the latch on the right side of the enclosure. At the same time pulling on the cover, as shown in Figure 3.

A 1/2" NPT threaded connection hole is provided in the bottom of the enclosure. Screw the EMT connector or cable gland connector in until tight. See Figure 4. It is recommended that weatherproof conduit or cable gland fittings be used. The F style enclosure includes a 1/2" NPT to M16 thread adapter and cable gland fitting.

Make wiring connections as per the "Wiring" illustrations on Page 2.

Swing door closed until securely latched. For added security, 2 screws are provided that may be installed in the integrated screw tabs. See Figure 5.

Figure 1

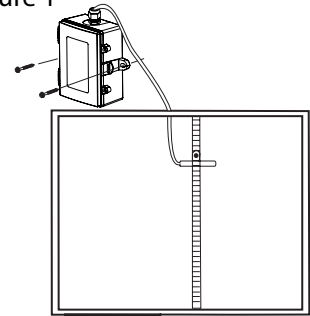

Figure 2

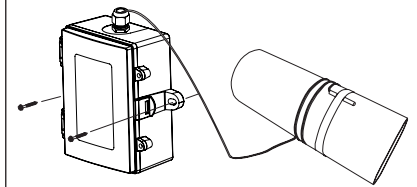

Figure 3

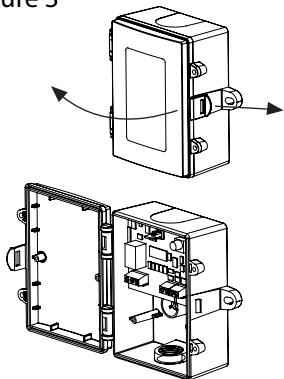

Figure 4

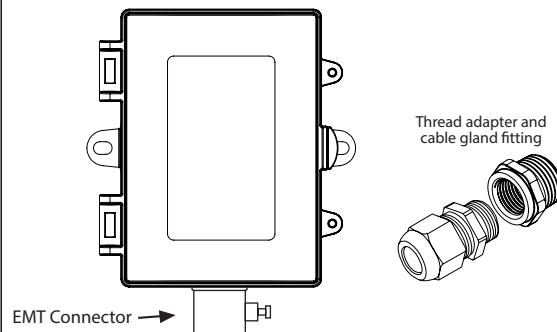
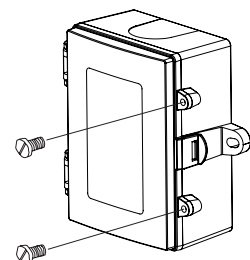
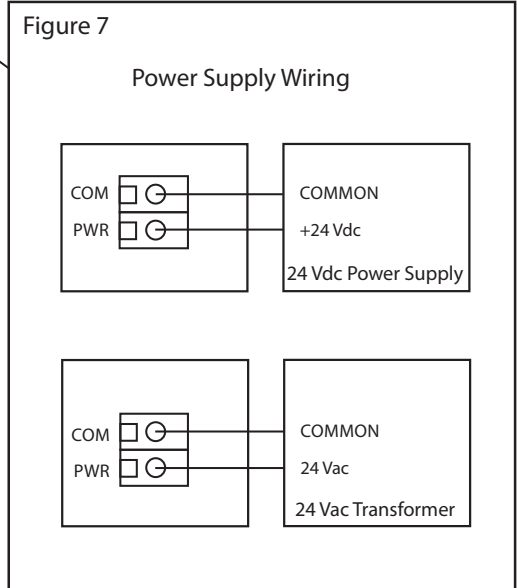
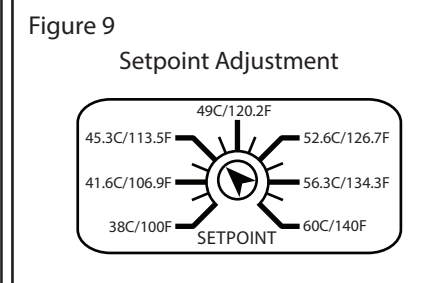
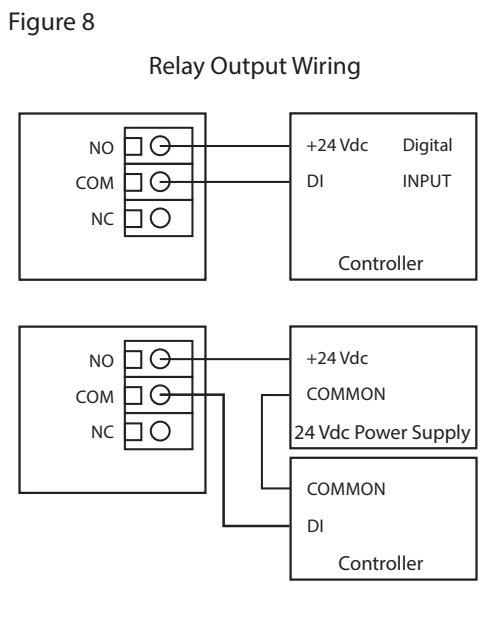
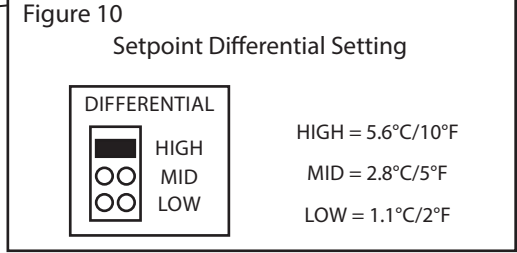
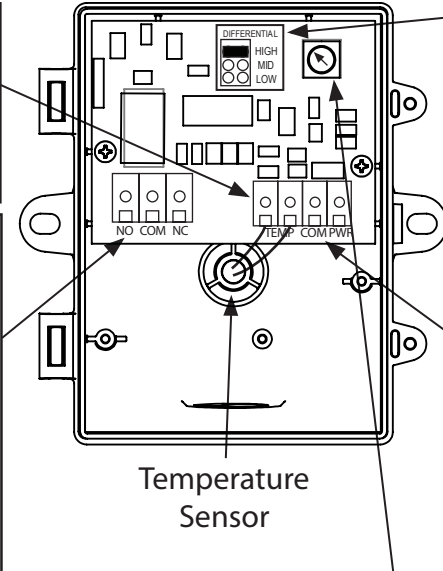
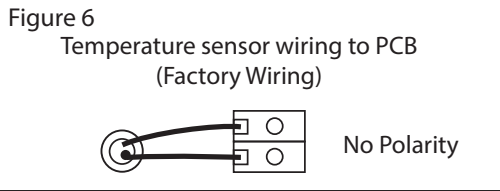

Figure 5



WIRING

- Deactivate the 24 Vac/dc power supply until all connections are made to the device to prevent electrical shock or equipment damage.
- Use 14-22 AWG shielded wiring for all connections and do not locate the device wires in the same conduit with wiring used to supply inductive loads such as motors. Make all connections in accordance with national and local codes.
- The temperature thermostat comes with the temperature sensor pre-wired to the PCB. If removal is required for installation then it may be re-wired as shown in Figure 6.
- Pull at least six inches of control wire into the enclosure, then complete the wiring connection according to the wire diagram for the applicable power supply as shown in Figure 7.
- Connect the DC positive or the AC voltage hot side to the PWR terminal. The supply common is connected to the COM terminal. See Figure 7.
- The relay has both Normally Open (NO) and Normally Closed (NC) contacts available. The relay output is available on the NO/COM/NC terminal. Make connections before applying power as shown in Figure 8.
- The setpoint differential has 3 jumper selectable settings (Low/Mid/High). Set jumper to desired differential as shown in Figure 10.
- To set the switching setpoint, turn the setpoint potentiometer to the desired temperature setting as shown in Figure 9.
- Once all connection settings are made and checked, power can be applied.



SPECIFICATIONS:

Power Supply:.....12 to 28 Vac/dc
 Consumption:.....50 mA max
 Relay Contacts:.....SPDT, Form C contacts (N.O. and N.C.)
 5 Amps @ 30 Vac/250 Vac resistive
 1.5 Amps @ 30 Vdc/250 Vac inductive
 Relay Action:.....Activates on temperature rise
 Setpoint Operation:.....Single-turn knob-pot on PCB
 Adjustable Setpoint:.....38 to 60°C (100 to 140°F)
 Setpoint Temperature:.....Low/Mid/High jumper selectable
 Differential 1.1, 2.8, 5.6°C (2, 5, 10°F)
 Temperature Sensor:.....10K ohm curve matched precision thermistor
 Sensor Accuracy:.....±0.2°C, 0 to 70°C (±0.36°F, 32 to 158°F)
 Probe Sensing Range:.....-20 to 60°C (-4 to 140°F)
 Probe Material:.....304 Series Stainless Steel
 Probe Diameter:.....6 mm (0.236")
 Wire Material:.....FT-6 Plenum-rated cable
 Wire Length:.....3.05m (10')
 Operating Conditions:.....-10 to 50°C (14 to 122°F), 5 to 95% RH, non-condensing
 Storage Conditions:.....-30 to 70°C (-22 to 158°F), 5 to 95% RH, non-condensing
 Wiring Connections:.....Screw terminal block (14 to 22 AWG)
 Enclosure:.....Grey Polycarbonate UL94-V0, IP65 (NEMA 4X)
 F style includes thread adapter (1/2" NPT to M16)
 and cable gland fitting
 Country of Origin:.....Canada

DIMENSIONS

