

TYPICAL INSTALLATION:

For complete installation and wiring details, please refer to the product installation instructions.

The duct type probes are installed through a hole in the side of the duct to monitor a single point temperature within the duct. Since the probes are tip sensitive, select a probe length that places the sensor well into the duct. Install the probe in a straight section of duct at a suitable distance downstream from any heating, cooling or humidification devices.

Each enclosure style provides mounting tabs on the outside for ease of installation.

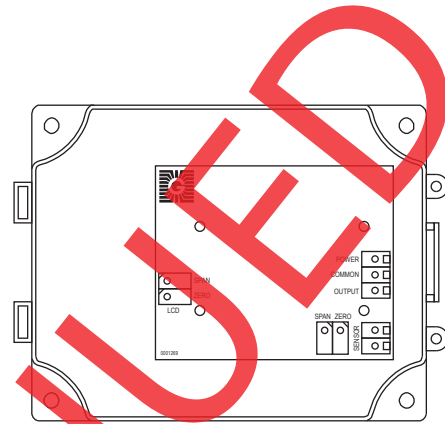
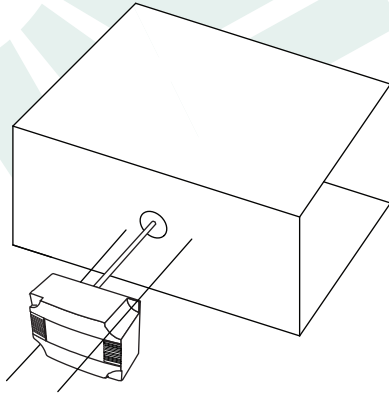

DIMENSIONS:

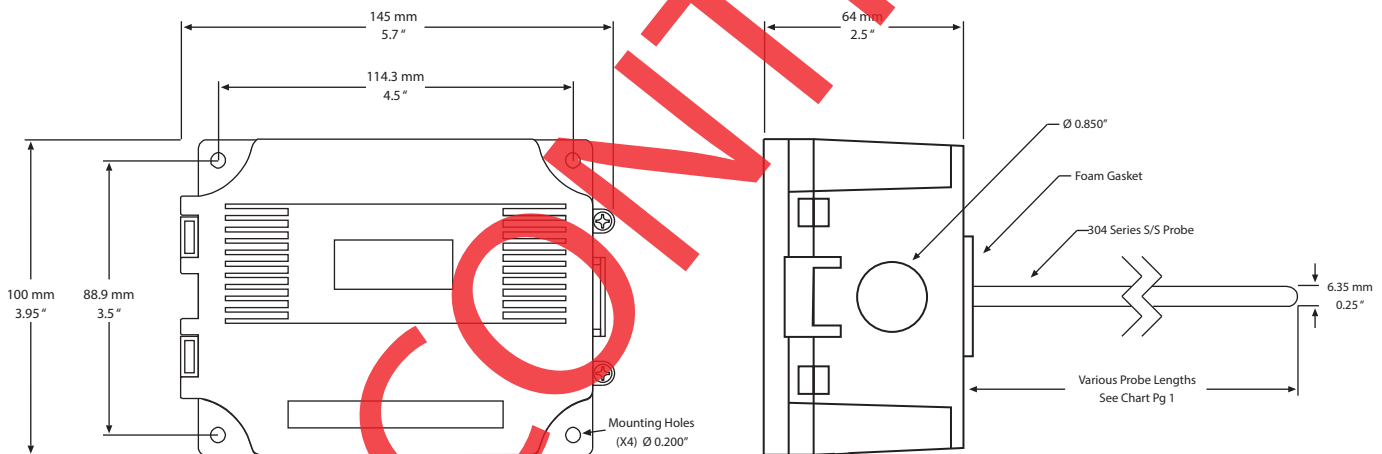

Greystone Energy Systems, Inc. reserves the right to make design modifications without prior notice.



GREYSTONE
ENERGY SYSTEMS INC
Greystone Energy Systems, Inc.
150 English Drive, Moncton,
New Brunswick, Canada E1E 4G7
(506) 853-3057 Fax: (506) 853-6014
North America: 1-800-561-5611
e-mail: mail@greystoneenergy.com
www.greystoneenergy.com

RoHS
COMPLIANT



Greystone Energy Systems Inc. is one of North America's largest ISO registered manufacturers of HVAC/R sensors and transmitters for Building Automation Management Systems. We have conscientiously established a worldwide reputation as an industry leader by maintaining leading-edge design technology, prompt technical support, and a commitment to on-time deliveries. We take pride in our Quality Management System which is ISO 9001 certified, assuring our customers of consistent product reliability.

GREYSTONE HAS AN ISO 9001 REGISTERED QUALITY SYSTEM