



## FLEX DUCT AVERAGE TEMPERATURE TRANSMITTER TE500FD Series

The TE500FD is a flexible, multi-point duct averaging mounted temperature transmitter and is available with a selection of platinum RTD sensors and a transmitter that provides a high accuracy signal with excellent long term stability, low hysteresis and fast response. They are available with various scaled ranges. The sensing cable is constructed to provide excellent heat transfer, fast response time and is available in several lengths and quantity of sensing elements.



### SPECIFICATION:

Sensor.....100 ohm Platinum RTD or  
1000 ohm Platinum RTD  
Sensor Accuracy.....±0.3°C (±0.54°F) @ 0°C (32°F)  
probe Sensing Range.....-20 to 60°C (-4 to 140°F)  
Sensing Cable.....FT-6 rated plenum cable  
Output Signal.....4-20mA current loop, 0-5 vdc, or  
0-10 Vdc (factory configured)  
Transmitter Accuracy .....±0.1% of span, including  
linearity  
4-20 mA loop power Supply .....15-35 Vdc or 22-32 Vac  
Minimum Current Loop .....2 mA nominal (occurs with  
shorted sensor)  
Maximum loop Current.....22.5 mA nominal (occurs with  
open sensor)  
Maximum Loop Load.....>600 ohms  
0-5 Vdc Power Supply .....10-35 vdc or 10-32 Vac  
0-10 Vdc Power Supply.....15-35 Vdc or 15-32 Vac  
Maximum Current (Voltage).....5 mA nominal  
Maximum Output (Voltage) .....limited to <5.5 Vdc for 0-5 Vdc,  
<10.5 for 0-10 vdc  
Input Voltage Effect.....Negligible over specified  
operating range  
RFI rejection.....Good RFI rejection of normal  
frequencies  
Protection Circuitry.....Reverse voltage protected and  
output limited  
Ambient Operating Range.....-40 - 85°C (-40 - 185°F), 0-95% RH  
non-condensing  
Enclosure.....(B) ABS, UL94-5VB, IP61 (NEMA 2)  
(E) ABS, UL94-5VB, IP65 (NEMA 4X)  
(D) - Gal. Steel, IP50 (NEMA 1)  
(C) - Cast Aluminum IP64 (NEMA3X)  
\*In order to maintain the  
published NEMA/IP ratings,  
properly rated conduit or cable  
gland adapters must be used.  
Wiring Connections.....Screw terminal block  
(14 to 22 AWG)

PART NUMBER SELECTED

### PRODUCT SELECTION INFORMATION:

MODEL	Product Description
TE500FD	Flex-Duct Average Temperature Transmitter

CODE	Enclosure (ABS enclosure is standard)
B	ABS enclosure, standard (no code required, leave blank)
E	Round ABS, w/gasketed cover
D	Metal utility box
C	Aluminum weatherproof box

CODE	Sensor
2	100 Ω Platinum, IEC 751, 385 Alpha, thin film
12	1000 Ω Platinum, IEC 751, 385 Alpha, thin film (Standard)

CODE	Cable Length/No. of Sensors
A	1800 mm (6') (4 Sensors)
B	3600 mm (12') (4 Sensors)
C	6100 mm (20') (4 Sensors)
D	7300 mm (24') (9 Sensors)

CODE	Output
1A	4-20mA
1D	0-5 Vdc
1E	0-10 Vdc

CODE	Scaled Range
1	0-35°C (32 - 95°F)
2	0-50°C (32 - 122°F)
*	Custom Range Contact Greystone

Greystone Energy Systems, Inc. reserves the right to make design modifications without prior notice.

## TYPICAL INSTALLATION:

For complete installation and wiring details, please refer to the product installation instructions.

The Flex-duct average sensing cable is installed through a hole in the side of the duct to monitor an average temperature within the duct. Select a probe length that allows for criss-crossing the duct multiple times. Install the probes in a straight section of duct at a suitable distance downstream from any heating, cooling or humidification elements.

Each enclosure style provides mounting tabs on the outside for ease of installation.

## DIMENSIONS:

ABS Enclosure

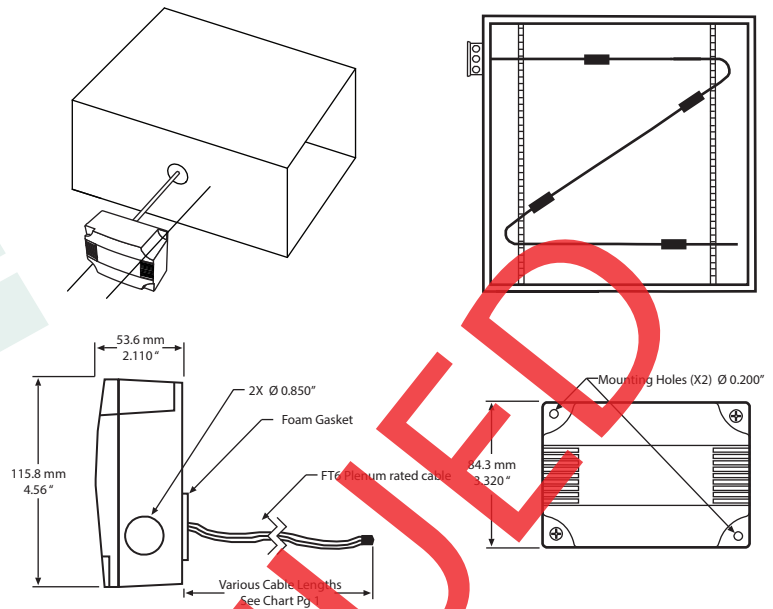
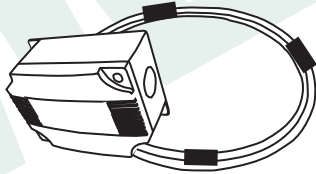

Round ABS Enclosure

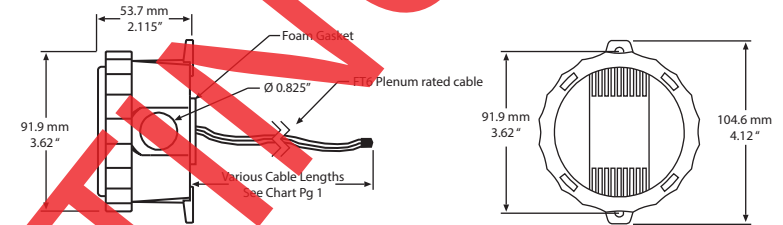
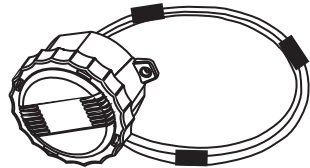

Metal Enclosure

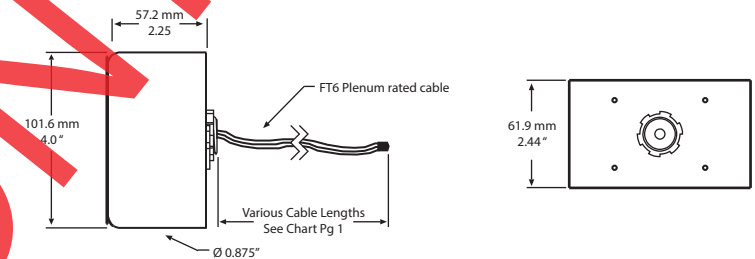
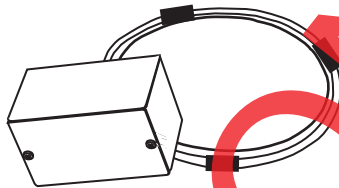

Weatherproof Enclosure

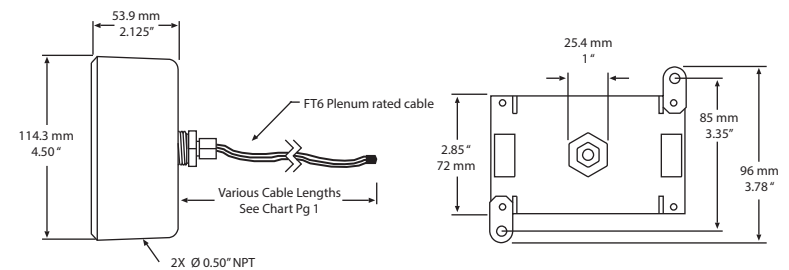
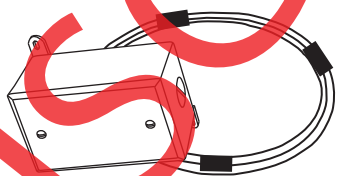

Greystone Energy Systems, Inc. reserves the right to make design modifications without prior notice.



**GREYSTONE**  
ENERGY SYSTEMS INC

Greystone Energy Systems, Inc.  
150 English Drive, Moncton,  
New Brunswick, Canada E1E 4G7  
(506) 853-3057 Fax: (506) 853-6014  
North America: 1-800-561-5611  
e-mail: mail@greystoneenergy.com  
www.greystoneenergy.com

**RoHS**  
COMPLIANT



Greystone Energy Systems Inc. is one of North America's largest ISO registered manufacturers of HVAC/R sensors and transmitters for Building Automation Management Systems.

We have conscientiously established a worldwide reputation as an industry leader by maintaining leading-edge design technology, prompt technical support, and a commitment to on-time deliveries. We take pride in our Quality Management System which is ISO 9001 certified, assuring our customers of consistent product reliability.

GREYSTONE HAS AN ISO 9001 REGISTERED QUALITY SYSTEM