



### ABS Enclosure



### Flex Duct Temperature Sensor

The averaging sensor incorporates several sensors encapsulated at equal distances across the length of the probe. The complete assembly acts as a single sensor to monitor the average temperature in a duct.

### Specifications

Standard Lengths	6', 12', 20' & 24'
Operating Temperature Range	-20 to 105 °C (-4 to 221 °F)
Cable Type	FT6 Plenum Rated (CSA)
Wiring Connections	Pig Tail (2 or 3 wire)
Enclosures	ABS, Metal or Weatherproof
Sensor Types	100 Ω, 1K PT, 1K Nickel RTD's, 1801 Ω, 3K, 10K (type 2 & 3),

### Other Enclosure Styles

#### Metal Enclosure



#### Weatherproof Enclosure



#### European Enclosure



### Installation

The flexible averaging sensors can be installed onto hangers in the duct using tube clamps or wire ties and should be located in a straight section of duct away from heating, cooling or humidifier elements. The flex duct sensor can be easily shaped to fit any duct size but observe a minimum bend radius of two inches to prevent damage to wires or sensors. Flex duct elements are not recommended for high humidity applications.

### Example Placement

PLACEMENT OF A 12' FLEX-DUCT SENSOR IN A 48" SQUARE DUCT

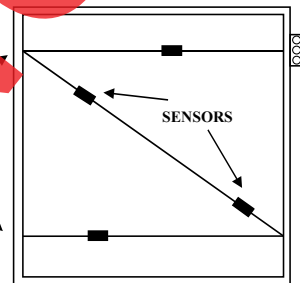

### Typical Wire Resistance Values

When using low resistance sensors (i.e. 100 ohm RTD), long wire runs can add significant error to the readings. Use the following chart to determine errors due to wire resistance or consider using a 1000 ohm sensor or a transmitter for better accuracy. Locate the type of wire being used. Multiply the total length of the wire (distance from the controller to the sensor and back) by the number found in the following chart for total resistance.

GAUGE WIRE TYPE	18 AWG	22 AWG	24 AWG
STRANDED (OHMS/FOOT)	5.85 mΩ	14.75 mΩ	23.29 mΩ
SOLID (OHMS/	6.4 mΩ	15.85 mΩ	25.72 mΩ

### Wiring & Color codes

All two-wire sensors are polarity insensitive. The three-wire sensors have the following color code:

Connection	Flex Duct Wire Color
EXCitation	RED
SENse	GREEN
NEGative	BLACK

To connect a three-wire sensor as a two-wire, tie the EXCitation and SENse lines together. All connections should be made using either butt-splices or soldering. The use of wire nuts is not recommended.

## Specifications

Power Supply . . . . . 15-35 Vdc or 12-26 Vac (no LCD)  
 22-35 Vdc or 18-26 Vac (with LCD)  
 Accuracy . . . . .  $\pm 0.1\%$  FSO  
 Operating Range . . . 0-70 °C (32-158 °F), 5-95 %RH  
 -40-85 °C (-40-185 °F) for OSA  
 Output Signal . . . . . 4-20 mA or 0-5 Vdc or 0-10 Vdc  
 Output Drive . . . . . >550 ohms (>325 ohms with LCD)  
 5K ohm min for voltage outputs  
 Wire Connections . . . Screw terminal block (14-22 AWG)  
 Standard Sensors . . . 100 ohm and 1000 ohm RTD

## Wiring

Use shielded twisted pair wiring of at least 22 AWG for all connections and do not run the signal or power wires in the same conduit with wiring used to supply inductive loads such as motors. Disconnect the power supply before making any connections to prevent electrical shock or equipment damage. Make all connections in accordance with national and local electrical codes.

The transmitter is available with either 4-20 mA, 0-5 Vdc or 0-10 Vdc output signals. Follow the example wiring diagrams to determine the correct wiring for the product. All models have the same terminal functions. For 4-20 mA loop powered operation, only **PWR** and **OUT** are required. The **COM** terminal is only used for voltage output types or for AC power.

Ensure the controller Analog Input (AI) matches the transmitter output signal type before power is applied. The device is reverse voltage protected and will not operate if connected backwards. The voltage output signal has a minimum load that it is able to drive and the current signal has a maximum load. Follow the ratings in the Specification section or inaccurate readings may result.

If the TE510 has a dual sensor probe, connect the RTD (Red/Black) leads to the **SENSOR** terminals. The second sensor is Green/White.

## Operation

The product should be allowed to warm-up for several minutes before attempting to verify accuracy. Allow the transmitter to operate for 20 minutes before any calibration is performed.

Operation can be verified by measuring the output signal. For voltage output models, measure the voltage between the **OUT** and **COM** terminals. The voltmeter should read between 0-5 or 0-10 Vdc depending on the model. For current output models, insert a mA meter in series with the **OUT** terminal and it should read between 4 and 20 mA. If an LCD is installed, it should indicate the same value as the output.

## Calibration

The unit can be calibrated in the field using precision resistance values equal to the zero and span of the temperature range. Simply replace the attached probe with the resistor, then adjust the **ZERO** and **SPAN** pots accordingly to obtain the correct output signal. Repeat the adjustments until both values are correct. Note the TE510 also has adjustments for the LCD which can be done at the same time. For units with 3-wire sensors, remember to jumper the **SEN** and **EXC** terminals with a wire.

Loop Powered Connection With Controller 24 Vdc Power

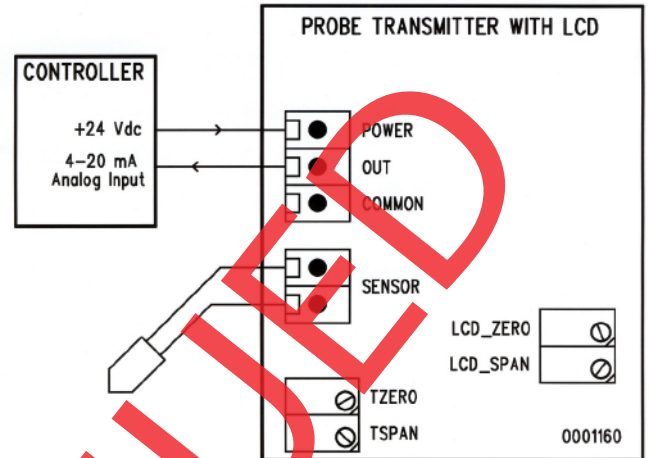

Voltage Connection With Controller 24 Vdc Power

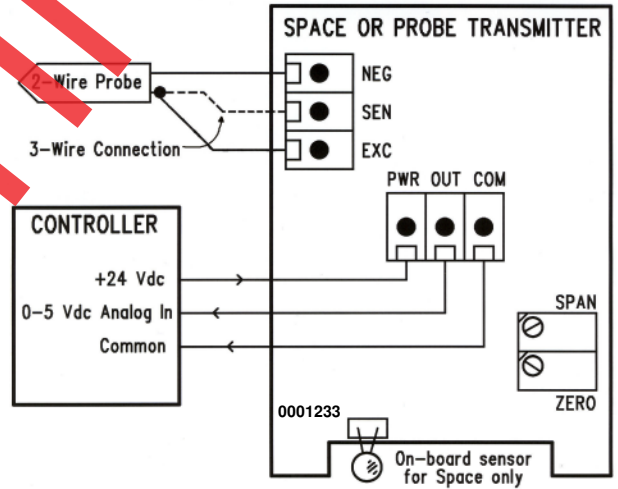

4-20 mA Connection With External 24 Vac Power

