

Description

The Low Pressure Transducer can be used to measure positive, negative or differential pressure in the ranges of 1"wc to 20"wc. The highly accurate piezoresistive sensor is ideal for monitoring pressure of non-corrosive, non-ionic working fluids such as clean dry air or other inert gases. It features field selectable pressure ranges and output signal types for the most flexible application. Typical HVAC applications include monitoring of filter differential pressure or clean room pressure. The output signal is factory calibrated and temperature compensated for highest startup accuracy and trouble-free operation.

Before Installation

Read these installation instructions carefully before commissioning the Pressure Transducer. Failure to follow these instructions may result in product damage. Do not use in an explosive or hazardous environment, with combustible or flammable gasses, as safety or emergency stop devices or in any other application where failure of the product could result in personal injury. Use electrostatic discharge precautions during installation and do not exceed the device ratings.

Mounting

Mount the Pressure Transducer on any surface using the two holes on the base of the unit. Ensure there is enough space around the unit to connect the pressure tubing without kinking and avoid locations with severe vibrations or excessive moisture. Mount the enclosure with two screws but do not over-tighten. It may be mounted in any position but typically is installed on a vertical surface with the pressure ports on the right and the cable entrance on the left. The enclosure has a standard ½" conduit opening and may be installed with either conduit and a conduit coupler or a cable gland type fitting.

Wiring Instruction

The transmitter has standard screw block connectors and easy wire access to facilitate wiring. It is recommended that shielded twisted pair wiring at least 22 AWG be used for all connections and that the device wires not be run in the same conduit with wiring used to supply inductive loads such as motors. Disconnect the power supply before making any connections to prevent electrical shock or equipment damage. Make all connections in accordance with national and local electrical codes.

The device power (24 Vac/dc) is connected to the terminal marked **PWR**. This terminal is used for the positive dc voltage or the hot side of the ac voltage. The device is reverse voltage protected and as such will not operate if connected backwards.

For voltage output signal types (3-wire) or for AC power supply operation (3-wire), the common of the power supply is connected to the terminal marked **COM**. Note that this device has a half-wave type power supply which means the power supply common is the same as the output signal common. Therefore, several devices may be connected to one power supply and the output signals all share the same signal common. Use caution when grounding the secondary of an ac transformer or when wiring multiple devices to ensure that the circuit ground point is the same on all devices and the controller. This terminal is not used for loop-powered 4-20 mA output type (2-wire).

The analog output signal is available on the **OUT** terminal. This signal is switch selectable for either a voltage output or a standard loop-powered 4-20 mA output signal type. When voltage mode is selected, either 0-5 Vdc or 0-10 Vdc can also be selected. These options are clearly indicated on the device circuit board. The analog output signal is typically connected directly to the Building Automation System (B.A.S.) and used as a control parameter or for logging purposes.

For voltage type output signal the device has a minimum load that it is able to drive, similarly for current type output signal the device has a maximum load that it is able to drive with a particular power supply voltage. Observe and follow these ratings in the Specification section or inaccurate reading may result. The 4-20 mA output signal can easily be converted to a 1-5 Vdc signal for controllers accepting this type of input. Simply insert a 250 ohm (0.1% is best) resistor between the "+" and "-" inputs of the controller. This will convert the 4-20 mA signal to the desired 1-5 Vdc.

Pneumatic Connections

The two pressure ports on the end of the enclosure are labeled **High** and **Low**. The output signal reads a positive value when the port pressure is higher on the **High** port than the **Low** port so ensure these ports are connected correctly. Use 0.170" I.D. flexible tubing for the pressure connections. Arrange the tubing to minimize stress on the connections and ensure there are no kinks in the tubing. For most accurate measurements, do not leave the **Low** port open to the atmosphere, run a return line from the **Low** port to the vicinity of the point being measured.

Ensure the tubing to be used is clean and do not allow material to fall into the pressure ports as contamination could damage the sensor. When removing tubing use care to avoid breaking the ports. In some cases it is better to cut the tubing off rather than pulling it off but be careful not to cut the fitting or an air leak may occur.

Configuration

The transmitter is configured with switches located on the circuit board as shown on the pcb drawing. These switches are used to select the output signal type and the input pressure range.

The unit is factory configured to operate in the 4-20 mA output mode. This can be changed to the voltage mode by moving the switch from the position marked **4-20 mA** to the position marked **Voltage**. Once the output mode is changed to voltage, the output scale may be changed to either 0-5 Vdc or 0-10 Vdc. This is done by moving the switch to the **5V** or **10V** position. The pressure range is set with a four position DIP switch. The available ranges are marked in the **MODEL** section on the circuit board. The pressure ranges are shown in the following chart:

Switch Setting	LP3-00	LP3-01	LP3-02	LP3-03	LP3-04	LP3-05
LOW	1" wc	3" wc	6" wc	10" wc	0.25 kPa	0.5 kPa
MID	2" wc	5" wc	10" wc	15" wc	0.5 kPa	1 kPa
HIGH	4" wc	8" wc	12" wc	20" wc	1 kPa	2 kPa

For example, if the LOW range is selected on the LP3-00 model, the pressure range will be 0-1" wc. If the 4th DIP switch labeled (+/-) is also set to ON, then the pressure range will be -1 to +1" wc. This means that each model has six pressure ranges. For the LP3-00 they will be 0-1, 0-2, 0-4, ± 1, ± 2 and ± 4 "wc.

Power Up Instruction

Before turning on the power, verify all wiring to ensure that it complies with one of the included wiring diagrams and verify that the output signal type is correctly selected with the switches. Also, review the specifications to ensure the power supply is correct and that the pressure is within the correct range. At this time, also inspect the internal pressure tubing that connects the sensor to the external ports to ensure that the tubing did not get kinked during shipping or installation.

Proper operation can be verified by measuring the output signal. For voltage output configuration, measure the voltage between the **OUT** and **COM** terminals. The voltmeter should read between 0-5 Vdc or 0-10 Vdc depending on the output range selected. For current output configuration, insert a mA meter in series with the **OUT** terminal. The mA meter should read between 4 and 20 mA.

Operation

If the unit is set to a unipolar range such as 0-2" wc, then the pressure applied to the **High** port must be higher than the pressure applied to the **Low** port. In this case, if the **Low** port is left open to ambient pressure and the **High** port is used to measure a positive pressure, then the output pressure can be calculated as follows:

4-20 mA Pressure = [(Output current – 4 mA) / 16 mA] x Range
 0-5 Vdc Pressure = (Output voltage / 5 V) x Range
 0-10 Vdc Pressure = (Output voltage / 10 V) x Range

In the case of 0-2" wc, 4 mA or 0 V = 0" wc and 20 mA or 5 V or 10 V = 2" wc. Since the transmitter is linear, 1" wc would be 12 mA or 2.5 V or 5 V. If the positive pressure connection is reversed then the transmitter will always output 4 mA or 0 V.

If the unit is set to a bipolar range such as ± 2" wc, then the pressure applied to the **High** port should be higher than the pressure applied to the **Low** port for a positive output response. In this case, differential pressure can be measured using both ports. If the **High** port has a positive pressure with respect to the **Low** port, then the output indicates a positive pressure. Negative pressure is indicated if the **High** pressure is less than the **Low** pressure. For bipolar ranges, the output pressure can be calculated as follows:

4-20 mA Pressure = [(Output current – 4 mA) / 16 mA] x 2 x Range – Offset
 0-5 Vdc Pressure = (Output voltage / 5 V) x 2 x Range – Offset
 0-10 Vdc Pressure = (Output voltage / 10 V) x 2 x Range – Offset

In the case of $\pm 2''$ wc, 4 mA or 0 V = -2'' wc and 20 mA or 5 V or 10 V = +2'' wc. Since the transmitter is linear, 0'' wc would be 12 mA or 2.5 V or 5 V.

Calibration

All pressure ranges are factory calibrated and no calibration is necessary. The user may adjust the zero point if desired when changing ranges for example. Make sure the unit is warmed up for at least 10 minutes (1 hour is best) before making a zero adjustment. With both ports open to the ambient pressure, press and hold the ZERO button for at least 3 seconds. Release the button after at least 3 seconds and the device will calculate and store the new zero point.

Generally, it is not recommended that the span calibration be performed in the field unless a high quality calibrator with low differential pressure ranges is available and the temperature of the sensor can be maintained. Contact the factory for information on this type of calibration.

Specifications

- Pressure Ranges (6 per model, switch selectable) . . . 0-1'', 0-2'', 0-4'', $\pm 1''$, $\pm 2''$, $\pm 4''$ wc
 0-3'', 0-5'', 0-8'', $\pm 3''$, $\pm 5''$, $\pm 8''$ wc
 0-6'', 0-10'', 0-12'', $\pm 6''$, $\pm 10''$, $\pm 12''$ wc
 0-10'', 0-15'', 0-20'', $\pm 10''$, $\pm 15''$, $\pm 20''$ wc
 0-0.25, 0-0.5, 0-1, ± 0.25 , ± 0.5 , ± 1 kPa
 0-0.5, 0-1, 0-2, ± 0.5 , ± 1 , ± 2 kPa
- Accuracy $\pm 0.5\%$ F.S.O.
- Measurement Type Differential (two port)
- Response Time 250 mS
- Stability $< \pm 1\%$ F.S.O. per year
- Thermal Effects $< \pm 3\%$ over compensated range
- Compensated Range 0 - 50 °C (32 - 122 °F)
- Proof Pressure 40'' wc all models (100'' wc for 12'' and 20'' models)
- Burst Pressure 60'' wc all models (200'' wc for 12'' and 20'' models)
- Operating Conditions 0 - 70 °C (32 - 158 °F), 10 - 90 %RH non-condensing

- Media Compatibility Non-corrosive, non-ionic fluids such as clean dry air or inert gases

- Power Supply 20 - 28 Vac/dc (non-isolated half-wave rectified)
- Supply Current < 4 mA
- Input Voltage Effect Negligible over specified operating range
- Protection Circuitry Reverse voltage protected and output limited

- Output Signal 4-20 mA (2-wire), 0-5 Vdc or 0-10 Vdc (3-wire), switch selectable

- Current Output Drive Capability 400 ohms max @ 24 Vdc
- Voltage Output Drive Capability 10K ohms min

- Zero Adjustment Pushbutton auto-zero
- Wiring Connections Screw terminal block (14 to 22 AWG)
- Pressure Connections Barbed ports for 0.170'' ID flexible tubing
- Conduit Connection Access hole for 1/2'' NPT conduit or cable gland
- Optional Display 3 1/2 digit LCD, 0.4'' digit height

- Enclosure High Impact Black ABS, plenum rated with optional gasket
 5.00" W x 3.3" H x 2.1" D (127mm x 84mm x 53mm)
- Weight 159 grams (5.6 oz)

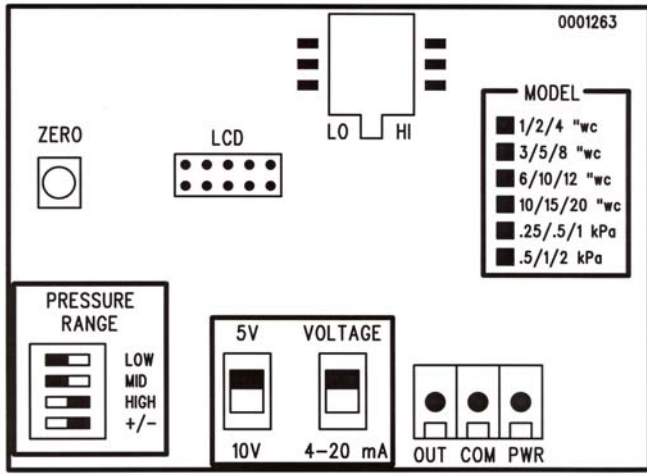

24 Vdc Power Supply, 0-5 Vdc Output

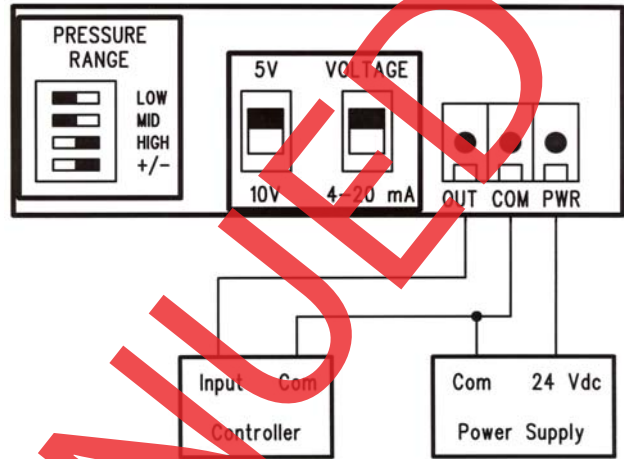

24 Vac Power Supply, 4-20 mA Output

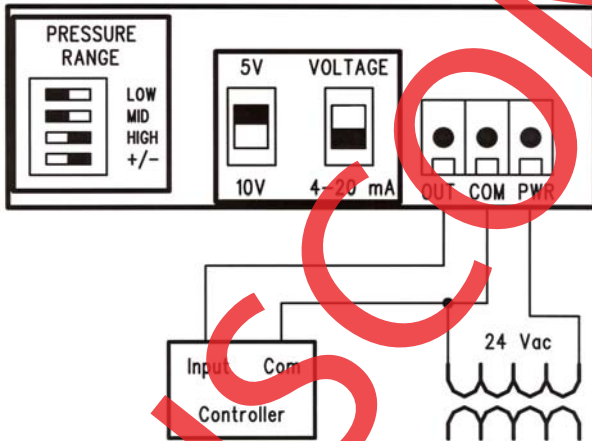

24 Vdc Power Supply, 4-20 mA Output

