



GREYSTONE ENERGY SYSTEMS INC

HIGH ACCURACY DUCT HUMIDITY /TEMPERATURE NETWORK SENSOR HANTD Series

The HANTD Series duct RH/temperature network sensor uses a highly accurate and reliable Thermoset Polymer based capacitance humidity sensor and curve-matched NTC thermistor temperature sensor together with embedded BACnet® or Modbus communication to provide the most efficient monitoring and control solution.

The device connects to an RS-485 MS/TP network to offer a single-point solution for control of indoor air comfort.

The HANTD Series is provided in an ABS enclosure with a 230 mm (9") S/S probe with porous filter that allows for ease of installation and protection from the elements.

SPECIFICATION:

General Specifications:

Power Supply.....	BACnet®: 24 Vac/dc ± 10% (non-isolated half-wave rectified) Modbus: 15 - 30 Vac/dc (non-isolated half-wave rectified)
Consumption.....	BACnet®: 25 mA max @ 24 Vdc Modbus: 10 mA max @ 24 Vdc
Protection Circuitry.....	Reverse voltage and over voltage protected
Operation Conditions.....	-40 - 50 °C (-40 -122 °F), 0-95% RH, non-condensing
Wiring Connections.....	Screw terminal block (14 to 22 AWG)
Enclosure.....	Grey ABS UL94-V0 - IP61 (NEMA 2)
Enclosure Dimensions.....	114 W x 84 H x 53 D mm (4.5" x 3.3" x 2.1")
Probe.....	230 mm (9") long x 12.7 mm (0.5") diameter Stainless steel with porous filter

Relative Humidity:

Sensing Element.....	Thermoset polymer based capacitive
Accuracy.....	± 1% (20 to 80% RH)
Range.....	0 - 100% RH
Resolution.....	0.1% RH
Hysteresis.....	± 1.5% RH
Response Time.....	15 seconds typical
Stability.....	± 1.2% RH typical @ 50% RH in 5 years

Temperature:

Sensing Element.....	20KΩ NTC thermistor
Accuracy.....	±0.1 °C (±0.18 °F) curve matched
Range.....	-40 - 50 °C (-40 - 122 °F)
Resolution.....	0.1 °C/°F

BACnet® Communications Interface:

Hardware.....	2-wire RS-485
Software.....	Native BACnet® MS/TP protocol
Baud Rate.....	9600, 19200, 38400 or 76800
Network Address Range.....	Locally set to 0-127

Modbus Communications Interface:

Hardware.....	2-wire RS-485
Software.....	Native Modbus MS/TP protocol (RTU)
Baud Rate.....	38400
Network Address Range.....	Locally set to 1- 255
Parity.....	None
Stop Bits.....	1
CRC.....	A001 (CRC-16 reverse)

* Modbus parameters may be factory customized



PART NUMBER SELECTED

PRODUCT SELECTION INFORMATION:

MODEL	Product Description
HANTDA	Duct Humidity/Temperature Network Sensor

CODE	Communications Output
BAC	BACnet®
MOD	Modbus

Greystone Energy Systems, Inc. reserves the right to make design modifications without prior notice.

BACnet® COMMUNICATION

BACnet® is a data communication protocol for building automation and control networks. The sensor communicates on a standard 2-wire RS-485 MS/TP network designed to run at speeds from 9600 to 76800 baud over twisted pair wiring.

BACnet® is a registered trademark of ASHRAE. ASHRAE does not endorse, approve or test products for compliance with ASHRAE standards. Compliance of BACnet® listed products to the requirements of ASHRAE Standard 135 is the responsibility of BACnet® International (BI). BTL is a registered trademark of BI.

MODBUS COMMUNICATION

Modbus is a network protocol for industrial manufacturing environments. The sensor communicates on a standard Modbus network using the RTU (Remote Terminal Unit) transmission mode. The hardware interface is RS-485.

TYPICAL INSTALLATION:

For complete installation and wiring details, please refer to the product installation instructions.

The duct type probes are installed through a hole in the side of the duct to monitor a single point humidity and temperature within the duct. Install the probe in a straight section of duct at a suitable distance downstream from any heating, cooling or humidification devices.

Mounting tabs on the outside of the enclosure for ease of installation.

A terminal block connection is provided for connection to the Building Automation System.

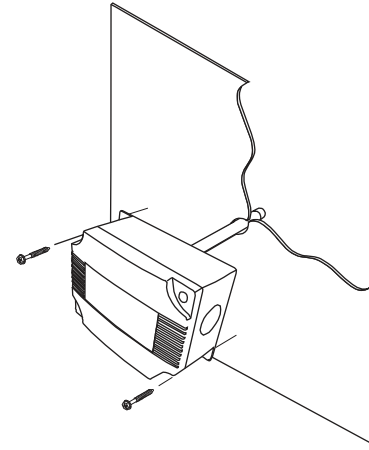

PCB/WIRING INFORMATION

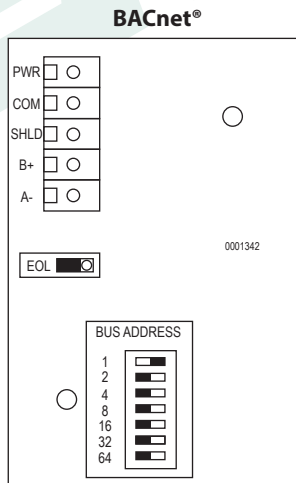

Terminal

PWR
COM
SHLD
B +
A -

Function

24 Vac/dc of controller or power supply
To GND or COMMON of controller
To communications bus shield
To + of communications bus
To - of communications bus

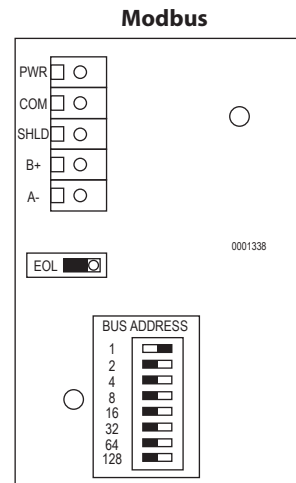

DIMENSIONS:

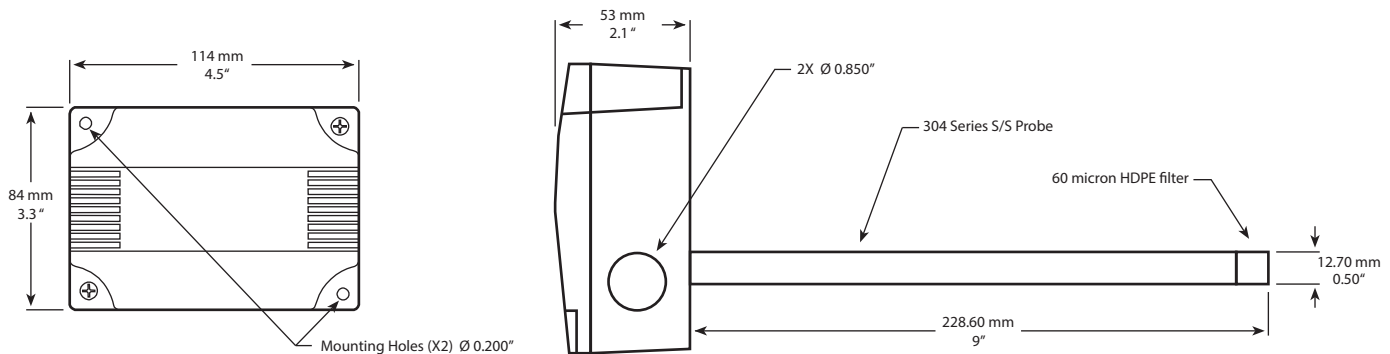

Greystone Energy Systems, Inc. reserves the right to make design modifications without prior notice.



GREYSTONE
ENERGY SYSTEMS INC

Greystone Energy Systems, Inc.
150 English Drive, Moncton,
New Brunswick, Canada E1E 4G7
(506) 853-3057 Fax: (506) 853-6014
North America: 1-800-561-5611
e-mail: mail@greystoneenergy.com
www.greystoneenergy.com

RoHS
COMPLIANT



Greystone Energy Systems Inc. is one of North America's largest ISO registered manufacturers of HVAC/R sensors and transmitters for Building Automation Management Systems. We have conscientiously established a worldwide reputation as an industry leader by maintaining leading-edge design technology, prompt technical support, and a commitment to on-time deliveries. We take pride in our Quality Management System which is ISO 9001 certified, assuring our customers of consistent product reliability.

GREYSTONE HAS AN **ISO 9001** REGISTERED QUALITY SYSTEM