

INTRODUCTION

The dual channel spot water detector is used to detect the presence of water or conductive liquids. It features two sensing points, each with an independent relay output and is designed to signal alarms if one or more of three conditions are met: water is detected, power is lost to the unit, or if there is an internal failure.

The dual channel spot water detector features spot detection on channel 1, with sensing probes protruding from the bottom of the enclosure and on channel 2, the selection of either remote spot or conductivity cable which are available in several lengths.

It is housed in an IP65 rated enclosure with height adjustable mounting legs. An LED provides visual status indication.

BEFORE INSTALLATION

- Read these instructions carefully before installing and commissioning the water detector. Failure to follow these instructions may result in product damage.
- Do not use in an explosive or hazardous environment, with combustible or flammable gases, as a safety or emergency stop device or in any other application where failure of the product could result in personal injury.
- **Take electrostatic discharge precautions during installation and do not exceed the device ratings.**

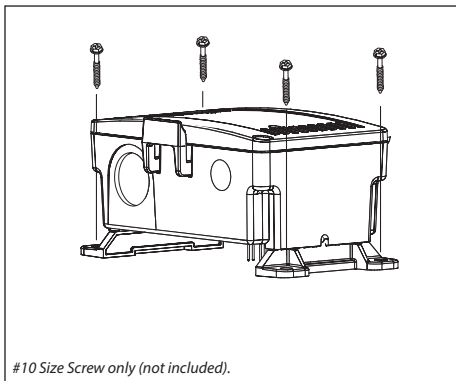
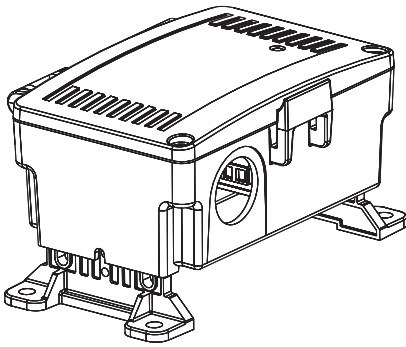

1 Select a suitable installation area to mount the device. Secure to the floor using silicone adhesive or with a #10 screw (not provided) using the integrated mounting holes.

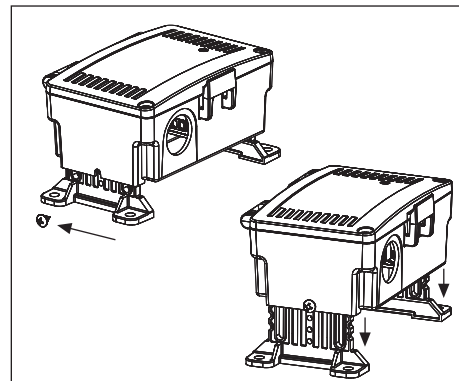

2 The legs have five pre-set heights. To adjust, remove screws from both legs. Pull/push the legs to the desired height, and re-insert screws.

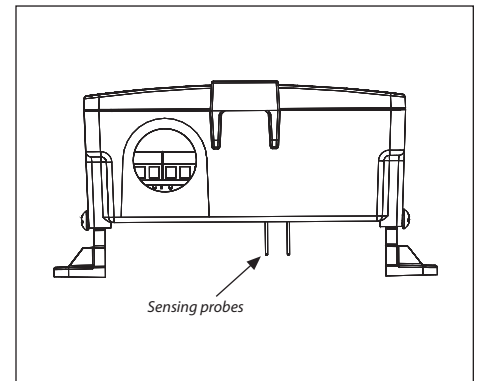

3 The sensing probes distance to floor is 1 mm (0.04") on lowest leg setting and 26.5 mm (1.04") on highest leg setting.

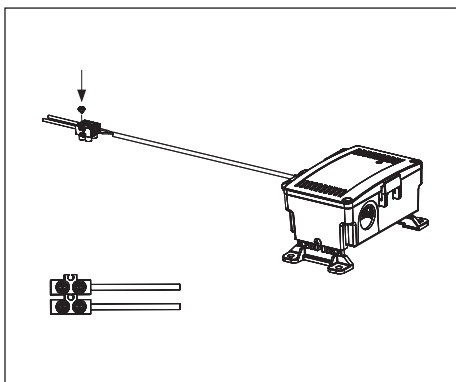

4 If channel 2 is remote spot detection, route the cable to desired location. Mount the terminal block using a screw or adhesive. Make sure sensing probes do not contact any surface.

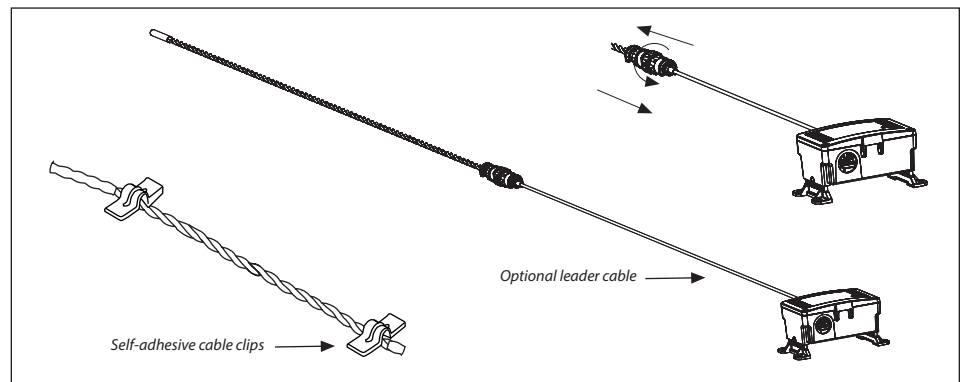

5 If Channel 2 is Conductivity Cable, Once laid in place, secure using the self-adhesive cable clips provided. For best results adhere clips at each end of the cable first. Clips are provided to secure cable approximately every 1.5 m (5').

NOTE: If the device was ordered with a leader cable, the conductivity cable can be disconnected to assist in installation. To remove, twist connector counter-clockwise and pull apart.

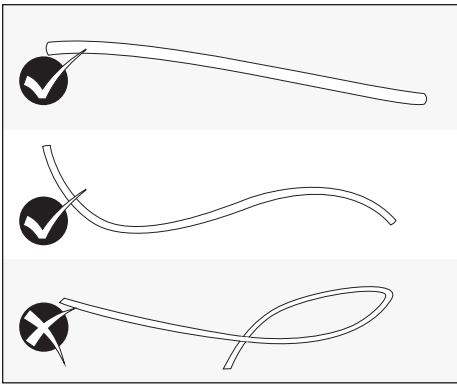

5 The cable may be laid in a straight line or in a serpentine configuration. Be careful not to kink cable.

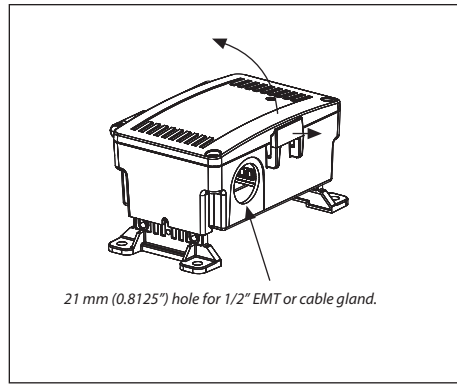

6 Open the cover by pulling slightly on the latch on the enclosure and at the same time pulling up on the cover.

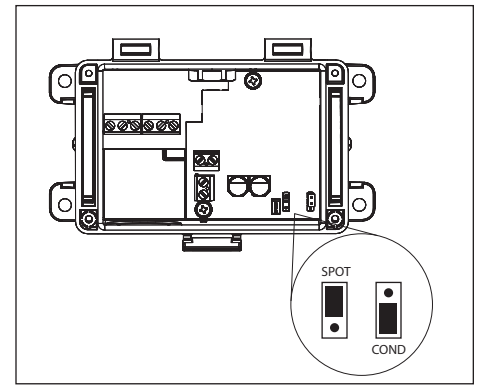

7 All jumpers are factory set. Improper positioning will cause device to be in constant alarm state.

Spot = SPOT position
Remote Spot = SPOT position
Conductivity Cable = COND position

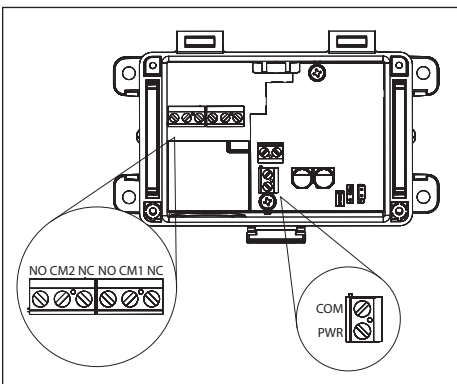

8 Make all connections in accordance with national and local codes. Use 14-22 AWG shielded wire and do not locate the device wires in the same conduit with wiring used to supply inductive loads such as motors. The device is reverse voltage protected and will not operate if connected backwards.

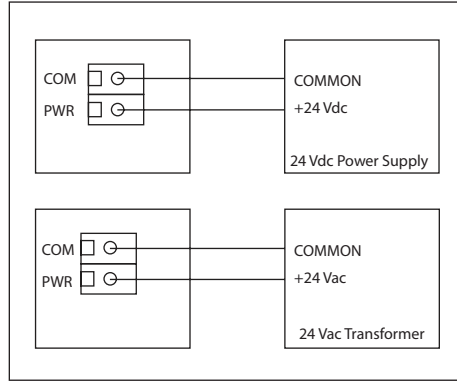

9 To prevent electrical shock or equipment damage make all connections before applying power. Connect 24 Vac/Vdc to PWR & COM terminals.

NOTE: Use caution when wiring multiple devices or when grounding the secondary of a transformer to ensure that the circuit ground point is the same on all devices and the controller.

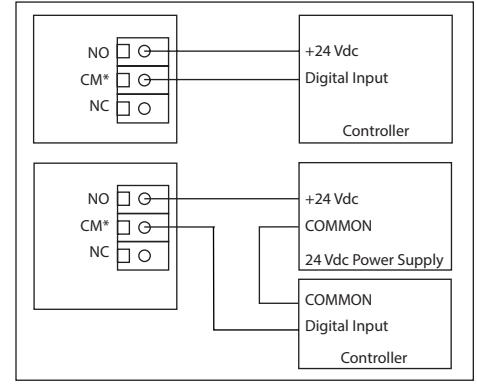

10 Do not exceed the device contact ratings. The relays are Form C type with both a normally open (NO) and a normally closed (NC) contact. Relay terminals are designated NO, CM* and NC.

NOTE: Each relay output is independent and isolated from the other and the relays COMs are not connected to the device COM.

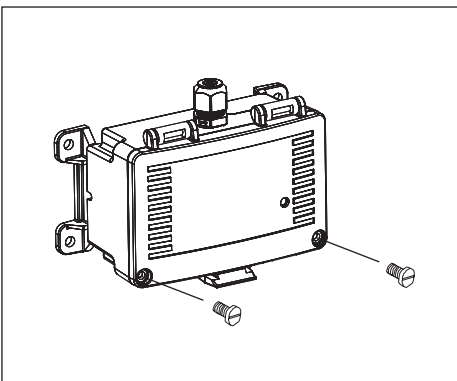

11 Use the provided security screws to secure the cover.

OPERATION

When the sensor is powered on the controller will monitor the liquid detection channels. If a conductive liquid comes in contact with the sensor probes or conductive cable the controller will trigger the relays to indicate liquid is present.

The relays are fail-safe, meaning when power is applied to device the relay is powered. If power is lost to device the relay will de-energize signaling a fault to the system.

Channel 1: Relay Activates on water detection.

Channel 2: Remote Spot: Relay activates on water detection.

Channel 2: Conductivity: Relay activates on water detection or trouble.

LED: Green = No water detected

Yellow Solid = Channel 1 Water Detection

Red Solid = Channel 2 Water Detection

Red Flash = Channel 2 Trouble (Conductivity Cable Only)

SPECIFICATIONS

POWER SUPPLY	12 - 27 Vac/dc
SUPPLY CURRENT	125 mA max @ 24 Vac
ALARM OUTPUT	1 or 2 Form C relay(s), NO/NC, rated 2 Amps @ 30 VAC/VDC, 0.5 Amps @ 120 VAC (resistive load)
VISUAL INDICATION	Tri-color LED - Green, Yellow, Red
OPERATING TEMPERATURE	0 to 50°C (32 to 122°F)
ENCLOSURE	ABS with hinged and gasket cover, IP65
DIMENSIONS	133.2mm L x 86.7mm W x 60.3-85.7mm H (5.2" x 3.4" x 2.4" - 3.4")
SENSOR PROBE HEIGHT	1 mm - 26.5 mm (0.04" - 1.04") Adjustable
CABLE TYPE (REMOTE SPOT)	FT-6 Plenum rated
APPROVALS	CE, RoHS
COUNTRY OF ORIGIN	Canada

DIMENSIONS

