

INTRODUCTION

The Ultra Low Pressure Transducer is used to measure differential pressure up to 1"wc or 250 Pa. It combines precision high sensitivity silicon sensing capabilities and the latest ASIC technology to substantially reduce offset errors due to changes in temperature, stability to warm-up, long term instability and position sensitivity. It is ideal for monitoring pressure for air or other clean inert gas. It features bi-directional pressure measurement, an on-board auto-zero function, a backlight LCD to display the pressure value and an alarm relay with variable trip points. The device is field-configurable via the local menu or the BACnet connection.

BEFORE INSTALLATION

Read these instructions carefully before installing and commissioning the Pressure Transducer. Failure to follow these instructions may result in product damage. Do not use in an explosive or hazardous environment, with combustible or flammable gases, as a safety or emergency stop device or in any other application where failure of the product could result in personal injury. **Take electrostatic discharge precautions during installation and do not exceed the device ratings.**

MOUNTING

The transmitter has two integrated mounting holes and best fastened with pneumatic ports in the down position. Ensure there is enough space around the unit to connect tubing without kinking by having gradual bends and no sharp angles that might restrict pressure reading. Avoid locations with severe vibrations or excessive moisture. The two mounting holes will facilitate a #10 size screw (not supplied). See Figure 1.

The enclosure has a standard 1/2" conduit opening and may be installed with either conduit and a conduit coupler or a cable gland type fitting.

The enclosure has a hinged cover with a latch. Open the cover by pulling slightly on the latch on the bottom of the enclosure. At the same time pulling on the cover, as illustrated in Figure 2.

A 1/2" NPT threaded connection hole is provided in the bottom of the enclosure. Screw the EMT connector or cable gland connector in until tight. See Figure 3. It is recommended that weatherproof conduit or cable gland fittings be used. The F style enclosure includes 1/2" NPT to M16 thread adapter and cable gland fitting.

Make wiring connections as per the "Wiring" illustrations on Page 2.

Swing door closed until securely latched. For added security, 2 screws are provided that may be installed in the integrated screw tabs. See Figure 4.

Figure 1

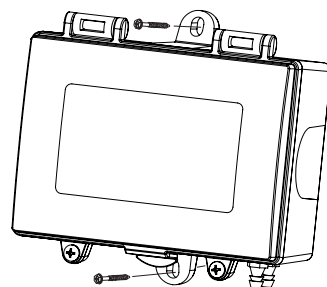

Figure 2

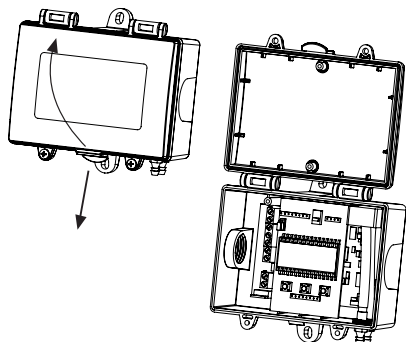

Figure 3

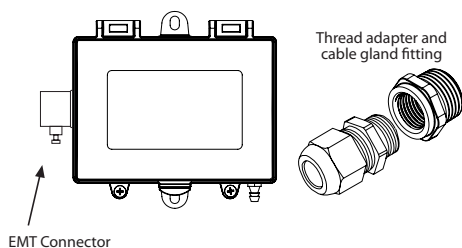
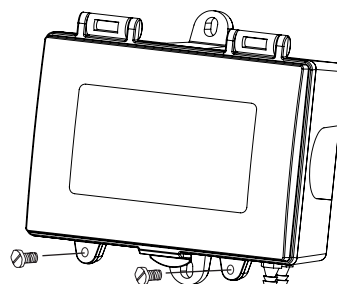

Figure 4



WIRING

The device has standard screw block connectors. Use shielded twisted pair wiring of at least 22 AWG for all connections and do not run device wires in the same conduit with wiring used to supply inductive loads such as motors. Disconnect the power supply before making any connections to prevent electrical shock or equipment damage. Make all connections in accordance with national and local electrical codes.

Connect the positive dc or the ac voltage hot side (24 Vac/dc \pm 10%) to the POWER terminal. The supply common is connected to the COMMON terminal. The device is reverse voltage protected and will not operate if connected backwards. Use caution if 24 Vac power is used and one side of the transformer is earth-grounded. In general, the transformer should NOT be connected to earth ground when using devices with RS-485 network connections.

Connect the RS-485 network with twisted shielded pair to the terminals marked A(-), B(+) and SHIELD. The positive wire connects to B(+) and the negative wire connects to A(-) and the cable shield must be connected to the SHIELD terminal on each device. If the device is installed at either end of an RS-485 network, an end-of-line (EOL) termination resistor (121 ohm) should be installed in parallel to the A(-) and B(+) terminals. This device includes a network termination jumper and will connect the 121 ohm resistor correctly on the PCB. Simply move the jumper to the EOL position and no external resistor is required. The ground wire of the shielded pair should be connected to earth ground at one end of the network. Do not run bus wiring in the same conduit as line voltage wiring or other wiring that switches power to highly inductive loads such as contactors, coils or motors.

A network segment is a single shielded wire loop run between several devices (nodes) in a daisy chain configuration. The total segment length should be less than 4000 feet (1220 meters) and the maximum number of nodes on one segment is 127. Nodes are any device connected to the loop and include controllers, repeaters and sensors such as the UP but do not include the EOL terminators. To install more than 127 devices, or to increase the network length, repeaters will be required for proper communication. The maximum daisy chain length (segment) depends on transmission speed (baud rate), wire size and number of nodes. If communication is slow or unreliable, it may be necessary to wire two daisy chains to the controller with a repeater for each segment.

The RELAY output is a normally open dry contact. This signal can be used to directly control an alarm, ventilation fan or may be connected to a digital input of the BAS for status monitoring. Ensure any loads connected to the relay are within the relay rating in the Specification section.

Figure 5

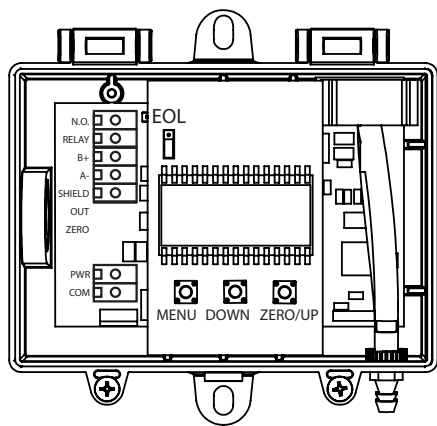
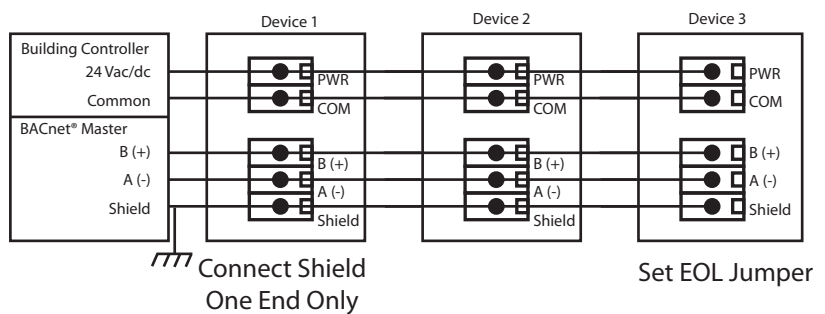

Figure 6



SET-UP

The device parameters must be set before connection to the network and will ensure that each device has a unique MAC address and Device Instance for startup. On startup, the MAC address is appended to the Device Object : Vendor Identifier to create the unique Device Instance (Device Object : Object Identifier). Once connected to a network, the Device Object : Object Identifier can be written to any unique value via BACnet and then the MAC address will no longer be appended to the value. All parameters are saved in memory. The local menu and LCD are used to set the BACnet MAC device address (0-127) and the baud rate. The factory defaults are address 3 and 9600 baud. The menu and setup procedure is described later.

Figure 7

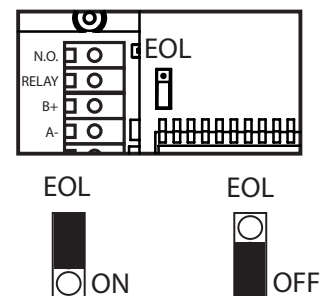

PNEUMATIC CONNECTIONS

The two pressure ports on the enclosure are labeled High and Low. The output value is positive when the port pressure is higher on the High port than the Low port so ensure these ports are connected correctly. Use 1/8" to 3/16" ID flexible tubing for the pressure connections. A flexible silicone tube is recommended. Arrange the tubing to minimize stress on the connections and ensure there are no kinks in the tubing. For most accurate measurements, do not leave the Low port open to the atmosphere, run a return line from the Low port to the vicinity of the point being measured.

Ensure the tubing to be used is clean and do not allow material to fall into the pressure ports as contamination could damage the sensor. When removing tubing use care to avoid breaking the ports. In some cases it is better to cut the tubing off rather than pulling it off but be careful not to cut the fitting or an air leak may occur.

NORMAL OPERATION

The device has a bipolar pressure range (± 1 "wc for example) so the pressure applied to the **HIGH** port should be higher than pressure applied to the **LOW** port for a positive output response. Differential pressure is measured using both ports. If the **HIGH** port has a positive pressure with respect to the **LOW** port, then the output indicates a positive pressure. Negative pressure is indicated if the High pressure is less than the **LOW** pressure.

During normal operation the device reads the pressure sensor and calculates the pressure value depending on the device model range. The pressure value is displayed on the LCD and sent to the pressure object.

The output value may be affected by the pressure averaging time setting in the menu. The pressure averaging setting controls how many readings are averaged to form the output value. The pressure averaging time defaults to 5 seconds and can be set from 1 to 60 seconds. This value effectively filters the output to prevent noise and false alarms.

The device also compares the output pressure value to the alarm setpoints and takes appropriate action. If the pressure value exceeds either setpoint then an alarm condition is set and the device will operate in alarm mode. Alarm mode activation is controlled by certain delay times and user settings described later. The device also monitors the keys and takes appropriate action if a key is pressed. The installer can enter the setup menu by pressing the <MENU> key at any time.

ALARM OPERATION

The alarm feature includes an on-board control relay and appropriate BACnet objects.

The alarm feature has several settings that can be controlled by the setup menu or via BACnet. The device has two alarm trip points designated the high pressure alarm limit and the low pressure alarm limit. The high pressure alarm defaults to 50% of the maximum pressure range and the low pressure alarm defaults to 50% of the minimum pressure range. For example, if the device has a ± 1 "wc range, then the default low pressure alarm limit will be -0.5 "wc and the default high pressure alarm limit will be +0.5 "wc. This is the same result for Pa ranges.

The alarm setpoints can be set over the pressure range with certain conditions. For this example the pressure range is ± 1 "wc.

- The low pressure alarm limit cannot go below the minimum pressure range setting (-1.0 "wc).
- The high pressure alarm limit cannot go above the maximum pressure range setting (+1.0 "wc).
- The high pressure alarm limit must always be greater than the low pressure alarm limit.
- The minimum alarm span (high alarm - low alarm) must be at least 25% of the pressure span (2 "wc x 25% = 0.5 "wc).
- If the minimum span is reached while adjusting one of the alarm limits, then the other alarm limit will be "pushed".

In this example for the ± 1 "wc range, these are some possible alarm settings: -1.0 to -0.5 "wc, -0.75 to -0.25 "wc, -0.5 to 0 "wc, -0.25 to 0.25 "wc, 0 to 0.5 "wc, 0.5 to 1.0 "wc.

The alarm also has settings for on delay and off delay which can be set via the menu or BACnet. Both of these default to 5 seconds but may be changed from 1-59 seconds or 1-10 minutes. For an alarm condition

to be set the pressure value must exceed either alarm trip point for more than the alarm on delay time. For an alarm condition to be reset the pressure value must return to a non-alarm value for more than the alarm off delay time.

When an alarm condition is set the relay output will activate. If the alarm condition is reset the relay output will deactivate. The alarm can be disabled via the menu or BACnet and no alarm will be activated.

AUTO ZERO OPERATION

A sensor auto zero can be initiated by pressing and holding the internal auto zero switch for at least 3 seconds. If both pressure ports are close to zero pressure (open to ambient), then the device will calibrate with a new zero point. The auto zero can also be initiated via BACnet. The device must be in the normal operating mode and close to zero differential pressure for the auto zero to initiate.

Generally, it is not recommended that a span calibration be performed in the field unless a high quality calibrator with low differential pressure ranges is available and the temperature of the sensor can be maintained. Contact the factory for information on this type of calibration.

START-UP

The Setup Menu can be accessed by pressing the internal <MENU> key at any time after the start-up mode.

The system suspends operation when in the menu and holds the last pressure value as the output value. If an alarm condition was present then it will be reset to enter the menu and alarm operation is disabled while in the menu (except for alarm test). If the Setup menu is not active for 5 minutes (no key press), then the menu will exit and the device returns to normal operation.

The Setup menu operation and parameters are explained below

<MENU> Press and release to enter the SETUP menu

1. PRESSURE SCALE



The pressure scale defaults to "wc. Use <UP> or <DOWN> to toggle it to Pa.

<MENU> Press to advance to next menu item

2. PRESSURE AVERAGING TIME



The pressure averaging time defaults to 5 seconds. This can be changed from 1 to 60 seconds using <UP> or <DOWN>.

<MENU> Press to advance to next menu item

3. ALARM



The alarm enable/disable defaults to enable (ON). The alarm can be disabled here. Use <UP> or <DOWN> to disable (OFF) the alarm. If the alarm is disabled, no alarm condition will be set. Note if the alarm is disabled, then none of the alarm settings will be shown in the menu

<MENU> Press to advance to next menu item

4. HIGH PRESSURE ALARM LIMIT



The high pressure alarm limit defaults to 75% of the range. This equals + 0.5 for the ± 1 "wc range, + 125 for the ± 250 Pa range, etc. It can be changed using <UP> or <DOWN> throughout the range. Resolution for each range is ± 1 "wc (0.05), ± 0.25 "wc (0.01), ± 250 Pa (10) and ± 60 Pa (2). Note that the ± 250 Pa range must be displayed as /10 such that it is - 25H to 25H.

<MENU> Press to advance to next menu item

5. LOW PRESSURE ALARM LIMIT



The low pressure alarm limit defaults to 25% of the range. This equals - 0.5 for the ± 1 "wc range, - 125 for the ± 250 Pa range, etc. It can be changed using <UP> or <DOWN> throughout the range. Resolution for each range is ± 1 "wc (0.05), ± 0.25 "wc (0.01), ± 250 Pa (10), ± 60 Pa (2). Note that the ± 250 Pa range must be displayed as /10 such that it is - 25H to 25H.

<MENU> Press to advance to next menu item

6. ALARM DELAY



The alarm on delay defaults to 5" (seconds). It can be changed from 1-59" (seconds) and 1-10' (minutes) using <UP> or <DOWN>.

<MENU> Press to advance to next menu item

7. ALARM DELAY



The alarm off delay defaults to 5" (seconds). It can be changed from 1-59" (seconds) and 1-10' (minutes) using <UP> or <DOWN>.

<MENU> Press to advance to next menu item

8. ALARM TEST



The alarm test defaults to OFF. It can be set to On using <UP> or <DOWN>. This forces the relay to activate.

<MENU> Press to advance to next menu item

9. MAC ADDRESS



The default BACnet® MAC address is 3. This can be changed from 0 to 127 using <UP> and <DOWN>

<MENU> Press to advance to next menu item

10. BAUD RATE



The default network baud rate is 96 (9600). It can be changed to 192 (19200), 384, 768 384 (38400) or 768 (76800) using <UP> or <DOWN>.

<MENU> Press to advance to next menu item



Press <MENU> or <ROLL> to exit the menu and return to normal operation.

SPECIFICATIONS

Pressure Ranges	UPB1B: $\pm 1''\text{WC} / \pm 250\text{Pa}$ UPB2B: $\pm 0.25''\text{WC} / \pm 60\text{Pa}$ UPB1A: $\pm 1'', 0-1'', \pm 0.5'', 0-0.5''\text{WC} / \pm 250, 0-250, \pm 125, 0-125\text{Pa}$ UPB2A: $\pm 0.25'', 0-0.25'', \pm 0.125'', 0-0.125''\text{WC} / \pm 60, 0-60, \pm 30, 0-30\text{Pa}$
Media Compatibility	Dry air or inert gas
Proof Pressure	UPB1: 100''WC (24.9 kPa) UPB2: 40''WC (9.96 kPa)
Burst Pressure	UPB1: 200''WC (49.8kPa) UPB2: 80''WC (19.9kPa)
Response Time	BACnet®: 1 to 60 seconds, menu or BACnet® selectable Analog: 1 to 60 seconds, menu selectable
Zero Adjust	BACnet®: Pushbutton or via BACnet® communication Analog: Pushbutton or via remote auto zero
Accuracy	$\pm 1\%$ F.S. of selected range @ 22°C (72°F)
Stability	$< \pm 1\%$ F.S.O. / year @ 22°C (72°F)
Operating Environment	0 to 50°C (32 to 122°F), 0 to 95%RH non-condensing
Storage Temperature	-30 to 60°C (-22 to 140°F)
Wiring Connection	14-22 AWG screw terminal block
Pressure Connection	6.35 mm (1/4'') Nylon barb fitting for 3.175 mm (1/8'') to 4.762 mm (3/16'') ID tubing
Conduit Connection	Access hole for 1/2'' NPT conduit or cable gland
Power Source UL	24Vac/Vdc ($\pm 10\%$); SELV (Class 2), non-isolated half-wave rectified Consumption: Analog @ 37mA max, BACnet® @ 52mA max
Outputs	Analog: 4-20mA (3-wire), 0-5 or 0-10Vdc (field select) Relay: N.O. SPST, 2 Amps @ 120Vac or 30Vdc Relay Trip Point: Upper & lower alarms adjust over pressure range Relay Delay: 0 to 10 minutes via keypad or BACnet®
Output Drive	Current: 750Ω max; Voltage: 2000Ω min
BACnet®	Communications: 2-Wire RS-485, BACnet® MS/TP protocol Baud Rate: Locally set to 9600, 19200, 38400, or 76800 MAC Address Range: Locally set to 0-127 (factory default is 3)
LCD Display	Size: 38.1 x 16.5 mm (1.5" x 0.65") Digit Height: 11.43 mm (0.45") Symbols: ''WC, Pa Backlight: Enable/disable/auto
Protection Class	III
Protection Circuitry	Reverse voltage protected and output limited
UL Model	MDPRSMCSUP
Certification	UL 60730 & CSA E60730, (UL E539555 file#)
UL2043 / CSA / ULC S142 Compliant	Suitable for Use in Air Handling Spaces in Accordance with Section 300.22, (C) of the National Electrical Code
Purpose of Control	Operating Control
Type of Action	Type 1
Impulse Voltage	330V
Pollution Degree	2
Enclosure	B: IP65 & NEMA 4X, Grey Polycarbonate UL94-V0 F: Same as B w/thread adapter (1/2'' NPT to M16) & cable gland fitting Liquid tight cable gland cord grip 1.7-5.8mm (0.067-0.228'')
EU Conformity / Approvals	CE / RoHS
Country of Origin	Canada

DIMENSIONS

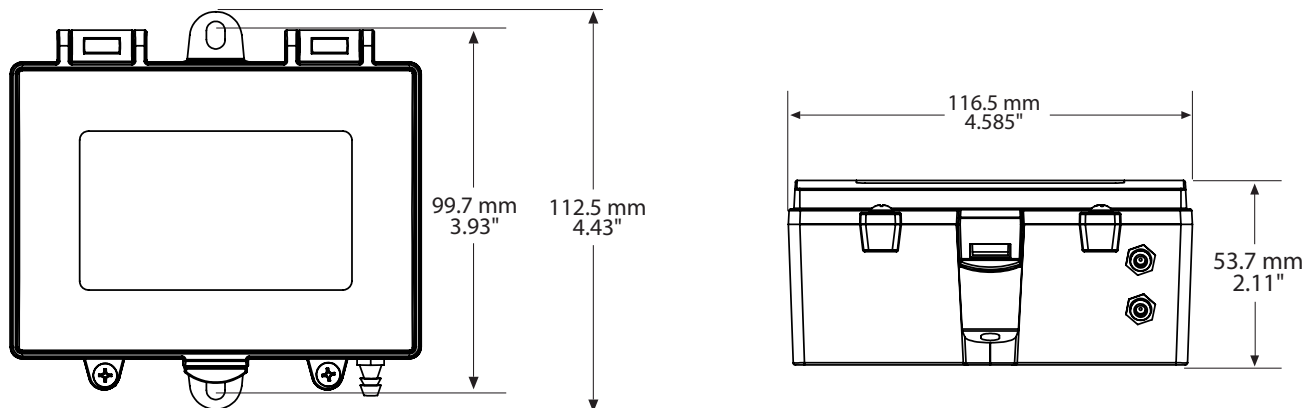

NETWORK SETUP GUIDE

The network setup guide describes the implementation of the BACnet® or Modbus protocol. It is intended to assist control system programmers who may need to add support to their systems to communicate with this device.

BACnet® setup guide download is available online.



BACnet® PROTOCOL

<https://downloads.greystoneenergy.com/Website%20Documents/UP/SG-UPXXXBAC-01.pdf>