

INTRODUCTION

The single point slab temperature sensor utilizes a precision sensor encapsulated in a thermal conductive coating and used to measure the temperature of a concrete slab. It is available with various sensor types, wire types and lengths. All probes are constructed to provide excellent heat transfer, fast response, and resist moisture penetration.

BEFORE INSTALLATION

Read these instructions carefully before installing and commissioning the device. Failure to follow these instructions may result in product damage. Do not use in an explosive or hazardous environment, with combustible for flammable gases, as a safety or emergency stop device or in any other application where failure of the product could result in personal injury. Take electrostatic discharge precautions during installation. **Do not exceed the device ratings.**

MOUNTING

ZW, FT & MP: Typically a predetermined area is defined where the temperature reading is required. During concrete installation a sufficient length of conduit or copper tubing is imbedded from this point to an area that will be accessible once complete. At the entrance to the sensor chamber, unravel the TSSL and carefully insert sensor and feed into chamber until the chamber end is reached.

A typical installation of this product is as follows: A predetermined area is defined where the temperature reading is required. During concrete installation a sufficient length of conduit or copper tubing is embedded from this point to an area that will be accessible once complete.

At the entrance to the sensor chamber, unravel the cable and carefully inset the sensor and feed it into the chamber until the chamber end is reached. See Figure 1.

MS: Unravel the sensor and lower the probe in the tank until below the liquid line or at desired depth. Secure cable to maintain depth. The probe may also be attached to the tank wall with some form of clamp at desired depth.

Once installed, complete the wiring instructions below.

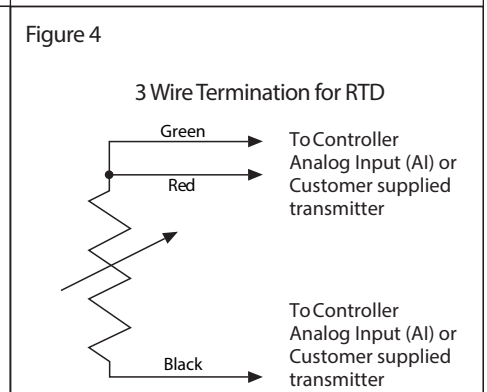
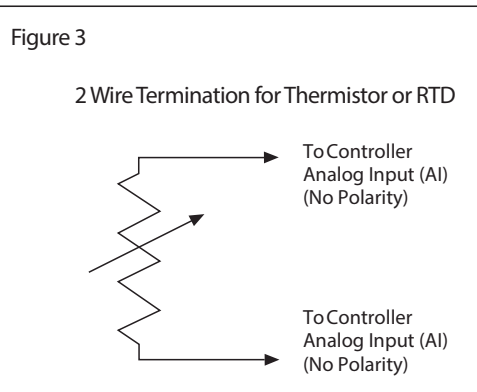
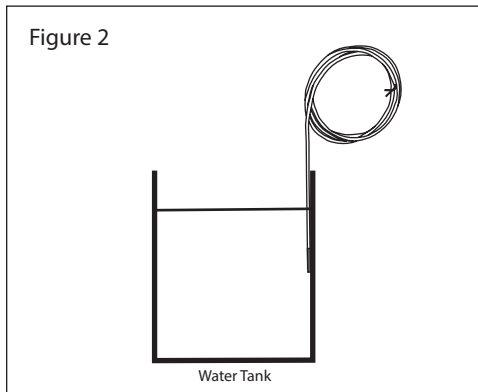
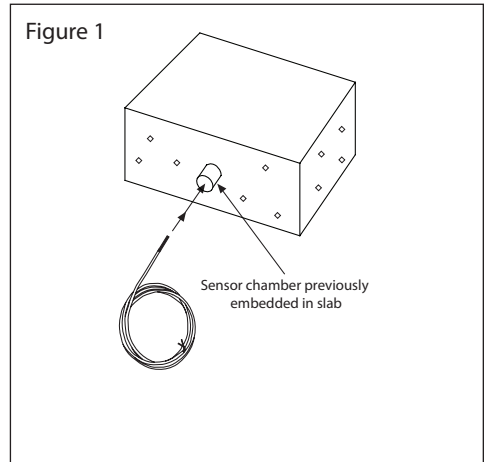

SPECIFICATIONS

Sensor Type	Various Thermistor or RTD
Temperature Range	ZW: -20 to 105°C (-4 to 221°F) FT: -20 to 60°C (-4 to 140°F) MP/MS: -20 to 80°C (-4 to 176°F)
Wire Material	ZW: PVC zip wire, 22 AWG FT: Plenum rate FT-6, 22 AWG MP: EPC moisture proof, 20 AWG MS: EPC Moisture proof, 20 AWG
Probe	MS: Double walled, 304 S/S, 12.7mm D x 101.5mm L (0.5" x 4")
Termination	Pigtail, 2 or 3 wire
Country of Origin	Canada

DIMENSIONS

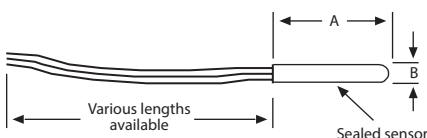

Model	A	B
ZW, FT, MP	25.4mm (1")	6.35mm (0.25")
MPS	101.6mm (4")	12.7mm (0.5")

TYPICAL WIRE RESISTANCE VALUES

When using low resistance sensors (i.e. 100 Ω RTD), long wire runs can add significant error to the readings. Use the following chart to determine errors due to wire resistance or consider using 1000 Ω sensor or a transmitter for better accuracy. Locate the type of wire being used. Multiply the total length of the wire (distance from the controller to the sensor and back) by the number found in the following chart for total resistance.

GAGE WIRE TYPE	18 AWG	22 AWG	24 AWG
STRANDED (OHMS/FOOT)	5.85 mΩ	14.75 mΩ	23.29 mΩ
SOLID (OHMS/FOOT)	6.4 mΩ	15.85 mΩ	25.72 mΩ