

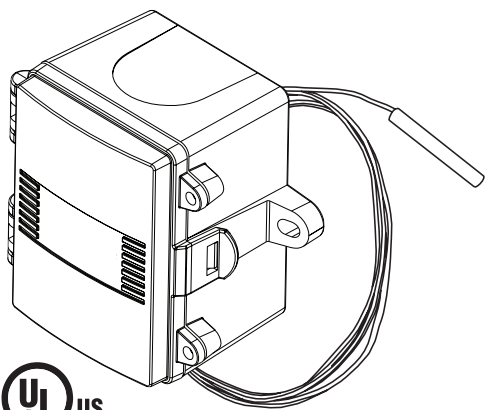

INTRODUCTION

The single point strap-on temperature transmitter incorporates a precision sensor encapsulated in a 6 mm (0.236") OD, 304 stainless steel probe and is available in various lengths. All probes provide excellent heat transfer, fast response and resist moisture penetration. A transmitter that provides a high accuracy signal with excellent long term stability, low hysteresis and fast response is provided. A compact ABS enclosure with a hinged and gasketed cover is provided for ease of installation.

Features include a -40 to 100°C (-40 to 212°F) temperature measurement range, high accuracy and resolution, and auto-detect baud rate. The network temperature sensor includes network variables for the temperature reading °C/°F units and calibration offset.



BEFORE INSTALLATION

Read these instructions carefully before installing and commissioning the temperature sensor. Failure to follow these instructions may result in product damage. Do not use in an explosive or hazardous environment, with combustible or flammable gases, as a safety or emergency stop device or in any other application where failure of the product could result in personal injury. **Follow electronic discharge precautions during installation and do not exceed the device ratings.**

MOUNTING

The strap-on sensor installs directly onto any pipe where an immersion sensor with a thermowell can't be installed.

Once a suitable spot is selected, remove a small section of insulation, if present, and set aside. It is recommended that thermal compound be used to improve heat transfer. Spread a liberal amount on the pipe. Lay probe in thermal compound and secure sensor to pipe using a worm gear clamp (not included). For added protection it is recommended to wrap probe cable around pipe 1 to 2 times as shown in Figure 1. Re-install insulation if present, allowing sensor cable to protrude.

Mount the enclosure on a flat surface in close proximity to the area where the probe inserted on the pipe. Secure the enclosure with two #10 x 25 mm (1") self tapping screws (not provided). As shown in Figure 2.

The enclosure has a hinged cover with a latch. Open the cover by pulling slightly on the latch on the right side of the enclosure. At the same time pulling on the cover, as shown in Figure 3.

A 1/2" NPT threaded connection hole is provided in the bottom of the enclosure. Screw the EMT connector or cable gland connector in until tight. See Figure 4. It is recommended that weatherproof conduit or cable gland fittings be used. The E style enclosure includes a 1/2" NPT to M16 thread adapter and cable gland fitting.

Figure 1

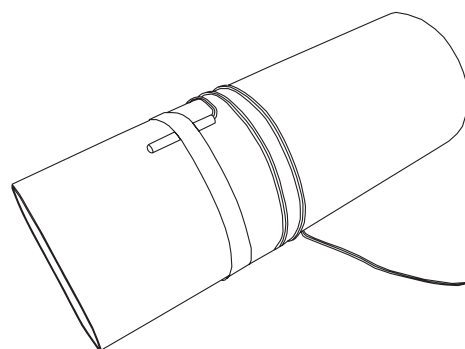

Figure 2

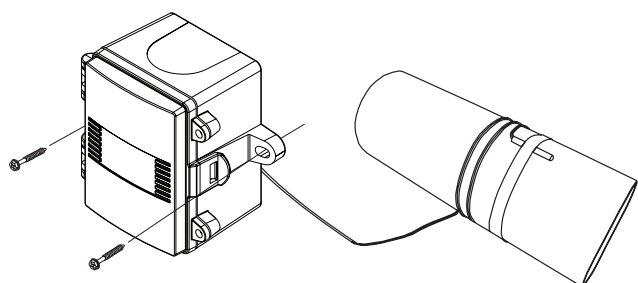

Figure 3

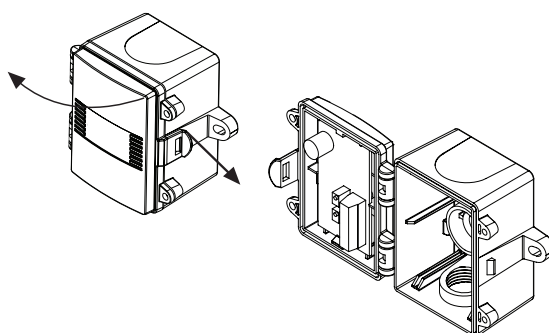

Figure 4

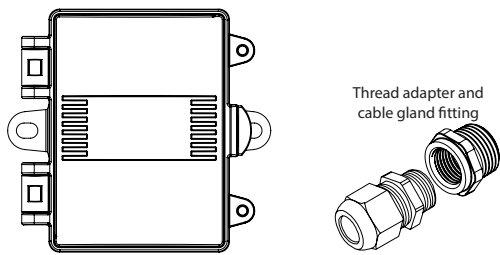
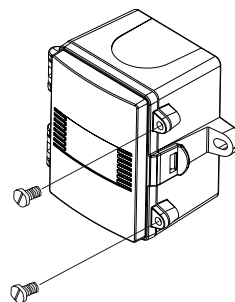

Figure 5



Make wiring connections as per the “Wiring” illustrations below.

Swing door closed until securely latched. For added security, 2 screws are provided that may be installed in the integrated screw tabs. See Figure 5.

WIRING

Deactivate the 24 Vac/dc power supply until all connections are made to the device to prevent electrical shock or equipment damage. Use 14-22 AWG shielded wire for all connections and do not locate the device wires in the same conduit with wiring used to supply inductive loads such as motors. Pull at least six inches of wire into the enclosure and complete the wiring connection according to the wiring diagram. Make all connections in accordance with national and local codes.

Connect the plus DC or the AC voltage hot side to the PWR terminal and the power supply common is connected to the COM terminal. The device has a half-wave power supply so use caution when wiring multiple devices so that the circuit ground point is the same on all devices and the controller.

Use caution if 24 Vac power is used and one side of the transformer is earth grounded. In general, the transformer should NOT be connected to earth ground when using devices with a RS-485 network connection. The device is reverse voltage protected and will not operate if connected backwards.

Connect the RS-485 network with twisted shield pair to the terminals marked A-, B+ and SHLD (shield) as shown in Figure 6.

The positive wire connects to B+ and the negative wire connects to A- and the cable shield must be connected to the SHLD terminal of each device. If the device is connected to the end of the network, and end-of-line (EOL) termination resistor (121 ohm) should be installed in parallel with the A- and B+ terminals.

This device includes a network termination jumper and will connect the resistor correctly on the PCB.

Figure 6

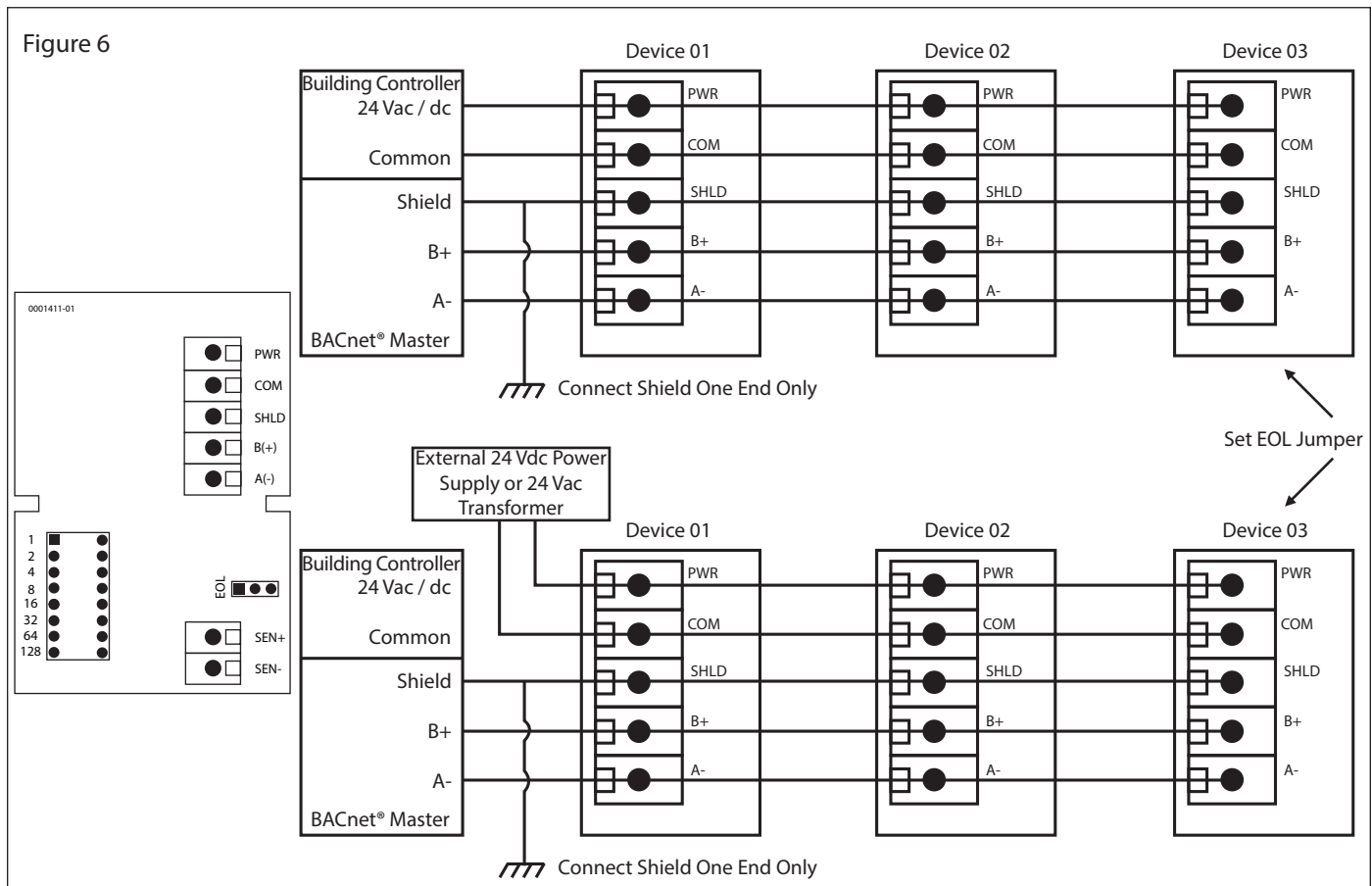

Simply move the PCB jumper to the EOL position as shown in Figure 7 and no external resistor is required.

The ground wire of the shielded pair should be connected to earth ground at the end of the network and the master is not grounded. Do not run bus wiring in the same conduit as line voltage wiring.

A network segment is a single shielded wire loop run between several devices (nodes) in a daisy chain configuration. The total segment length should be less than 4000 feet (1220 meters) and the maximum number of nodes on one segment is 127.

Nodes are any device connected to the loop and include controllers, repeaters and sensors such as the Network Temperature Sensor but does not include the EOL terminators.

To install more devices, or to increase the network length, repeaters will be required for proper communication. The maximum daisy chain length (segment) depends on transmission speed (baud rate), wire size and number of nodes. If communication is slow or unreliable, it may be necessary to wire two daisy chains to the controller with a repeater for each segment.

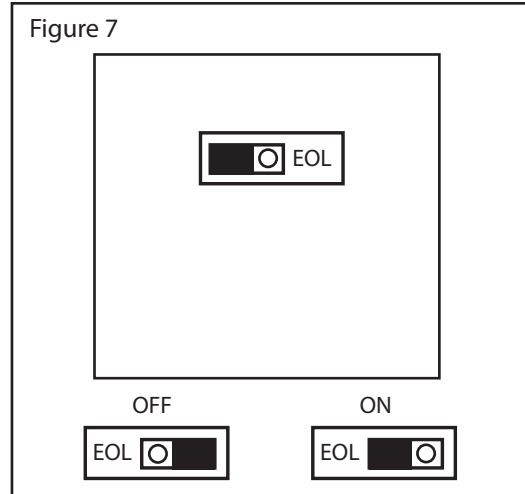

LED OPERATION

In normal operating mode, the LED blinks for 30 seconds on start-up at 1 Hz, then indicates a communication activity. If the sensor reading is out of range then the LED stays on constantly to indicate a defect or over / under range condition.

NETWORK COMMUNICATION

The device parameters must be set before connection to the network and will ensure that each device has a unique MAC address and Device Instance for startup. On startup, the MAC address is appended to the Device Object : Vendor Identifier to create the unique Device Instance (Device Object : Object Identifier). Once connected to a network, the Device Object : Object Identifier can be written to any unique value via BACnet and then the MAC address will no longer be appended to the value. All parameters are saved in memory. The PCB DIP switch is used to set the BACnet address (0-127) as shown in Figure 8.

Note that the BACnet network baud rate may be 9600, 19200, 38400, 57600, 76800 or 115200 and is auto-detected on startup.

The sensor operates as a slave. It will not communicate unless a master is connected to the network and sends a request for information, then the slave will answer. If the device does not communicate properly, first check that the communication wires are not reversed. Then check that the slave address has a unique setting for the network segment it is connected to. Ensure the device object name and object identifier are unique on the entire BACnet network, not just on the MS/TP sub-net. Both of these properties are writable.

Ensure the application software is not set to poll the devices too frequently. For example, if the software is polling the devices every 500 mS, the network could be heavily congested with the network traffic and may not operate reliably. A slower polling rate such as 5 to 10 seconds will usually produce better results on a typical network segment.

Use care when setting the MS/TP MAC address and the device object Max_Master property since both can have a significant effect on the network efficiency. Some MAC address and Max_Master combinations will operate more efficiently than others. MAC addresses should be selected sequentially, starting at the lowest possible value. For example, on a five node segment, the MAC addresses should be set to 1, 2, 3, 4 and 5. In this case, if the Max_Master property value is left at the 127 default, then there will be a lot of wasted time on the network polling for masters that are not present. In this example, the five RH/T nodes should be set such that Max_Master is equal to 5. The Max_Master value initially defaults to 127 so that any master can be found when the device first starts.

Figure 8

DIP Switch Position								BACnet® Address
128	64	32	16	8	4	2	1	
Not Used	OFF	OFF	OFF	OFF	OFF	OFF	OFF	0
↓	OFF	OFF	OFF	OFF	OFF	OFF	ON	1
↓	OFF	OFF	OFF	OFF	OFF	ON	OFF	2
↓	OFF	OFF	OFF	OFF	OFF	ON	ON	3
↓	↓	↓	↓	↓	↓	↓	↓	↓
↓	ON	ON	ON	ON	ON	ON	OFF	126
Not Used	ON	ON	ON	ON	ON	ON	ON	127

1

2

4

8

16

32

64

128

OFF

ON

BACnet® PROTOCOL

The device has BACnet objects to identify the device, read the current temperature value, calibrate the sensor and set the temperature units. There are four standard supported BACnet objects as shown below.

Object Type	Object Identifier	Object Name	Description	Default
Device	381001	TN-001		381001
Analog Input	AI 1	Temperature	-40 to 100°C, Resolution = 0.1°C -40 to 212°F, Resolution = 0.1°F	
Analog Value	AV 1	Temperature Offset	-5 to 5 Δ°C, Resolution = 0.1 Δ°C -10 to 10 Δ°F, Resolution = 0.1 Δ°F	0.0 Δ°C 0.0 Δ°F
Binary Value	BV 1	Temperature Units	0 = °C, 1 = °F	°C

DEVICE OBJECT: 381001 TN-001

Property	Default Value	Property Data Type	Access
Object Identifier	381001	BACnetObjectIdentifier(numeric)	Read/Write
Object Name	TN-001	CharacterString (32)	Read/Write
Object Type	DEVICE (8)	BACnetObjectType	Read
System Status	Operational (0)	BACnetDeviceStatus	Read
Vendor Name	Greystone Energy Systems	CharacterString	Read
Vendor Identifier	381	Unsigned16	Read
Model Name	TN	CharacterString	Read
Firmware Revision	1.0	CharacterString	Read
Application Software Version	V1.0	CharacterString	Read
Location	150 English Drive, Moncton, NB	CharacterString (32)	Read/Write
Description	Greystone Temp Sensor	CharacterString (32)	Read/Write
Protocol Version	1	Unsigned	Read
Protocol Revision	14	Unsigned	Read
Protocol Services Supported	See description below	BACnetServicesSupported	Read
Protocol Object Types Supported	See description below	BACnetObjectTypesSupported	Read
Object List	See description below	BACnetArray	Read
Maximum APDU Length Accepted	50, B'0000'	Unsigned	Read
Segment Supported	NO SEGMENTATION (3)	BACnetSegmentation	Read
ADPU Timeout	6000	Unsigned	Read/Write
Number of ADPU Retries	3	Unsigned	Read/Write
Max Master	127	Unsigned	Read/Write
Max Info Frames	1	Unsigned	Read
Device Address Binding	empty	BACnetAddressBinding	Read
Database Revision	0	Unsigned	Read
Property List		BACnetArray	Read

Object Identifier

Initial default number is 381001, where 381 is the vendor ID and 001 is the default network MAC address. When the MAC address is initially changed the value is updated and saved. For example, if the MAC address is set to 50 via the DIP Switch for startup, then the device instance will be set to 381050. This property is also writable via BACnet. If the Device:Object_Identifier is written to via BACnet then the MAC address is no longer appended to the vendor ID to create this value.

Object Name Initial string is "TN-001" where TN is the device model name and 001 is the default network address. Can be written with a new string of maximum length of 32 characters and the value is saved. The "001" is the MAC address as set by the DIP Switch and is automatically changed if the MAC address is changed. Once written to via BACnet, the MAC address no longer gets appended to the value.

Protocol Services Supported readProperty, readProperty-Multiple, writeProperty, deviceCommunicationControl, who-Has, who-Is
Binary bit string = {00000000 00001011 01000000 00000000 01100000 0}

Protocol Object Types Supported Device, Analog_Input, Analog_Value, Binary_Value, Device
Binary bit string = {10100100 10000000 00000000 00000000 00000000 00000000 00000000 00000000}

Object List ((Device, Instance 1), (Analog Input, Instance 1), (Analog Value, Instance 1), (Binary Value, Instance 1))

APDU Timeout Value is 6,000. Can be modified from 1 to 10,000.

Number Of APDU Retries Value is 3. Can be modified from 1 to 10.

Max Master Value is 127. Value is saved. Can be modified from 1 to 127.

Database Revision Value is 0 to 255.

ANALOG INPUT OBJECT: AI1 TEMPERATURE

Property	Default Value	Property Data Type	ACCESS
Object Identifier	AI1 (Analog Input 1)	BACnetObjectIdentifier	Read
Object Name	Temperature	CharacterString (32)	Read
Object Type	ANALOG_INPUT (0)	BACnetObjectType	Read
Present Value	current reading	Real	Read
Description	Temperature	CharacterString (32)	Read
Device Type	Temperature Sensor	CharacterString (32)	Read
Status Flags	{false, false, false, false} (0000) or (1100) if no sensor	BACnetStatusFlags	Read
Event State	NORMAL (0) or FAULT (1) if no sensor	BACnetEventState	Read
Reliability	NO_FAULT_DETECTED (0) or NO SENSOR (1)	BACnetReliability	Read
Out of Service	FALSE (0)	Boolean	Read
Units	degrees-Fahrenheit (64) or degrees-Celsius (62)	BACnetEngineeringUnits	Read
Property List		BACnetArray	Read

Rules Enforced: -40°C <= Present Value <= 100°C, Resolution = 0.1°C
-40°F <= Present Value <= 212°F, Resolution = 0.1°F

ANALOG VALUE OBJECT: AV1 TEMPERATURE OFFSET

Property	Default Value	Property Data Type	ACCESS
Object Identifier	AV1 (Analog Value 1)	BACnetObjectIdentifier	Read
Object Name	Temperature Offset	CharacterString (32)	Read
Object Type	ANALOG_VALUE (2)	BACnetObjectType	Read
Present Value	0	Real	Read/Write
Description	Temperature Offset	CharacterString (32)	Read
Status Flags	{false, false, false, false} (0000)	BACnetStatusFlags	Read
Event State	NORMAL (0)	BACnetEventState	Read
Out of Service	FALSE (0)	Boolean	Read
Units	delta-degrees-Fahrenheit (120) or Δ°C (121)	BACnetEngineeringUnits	Read
Property List		BACnetArray	Read

Rules Enforced:

-5.0 Δ°C ≤ Present Value ≤ 5.0 Δ°C, Resolution = 0.1 Δ°C
-10.0 Δ°F ≤ Present Value ≤ 10.0 Δ°F, Resolution = 0.1 Δ°F
Units depend on the device units, either °C or °F
Changing units always resets Present Value to 0

BINARY VALUE OBJECT: BV1 TEMPERATURE UNITS

Property	Default Value	Property Data Type	ACCESS
Object Identifier	BV1 (Binary Value 1)	BACnetObjectIdentifier	Read
Object Name	Temperature Units	CharacterString (32)	Read
Object Type	BINARY_VALUE (5)	BACnetObjectType	Read
Present Value	INACTIVE (0)	BACnetBinaryPV	Read/ Write
Description	Celsius (0) or Fahrenheit (1)	CharacterString (32)	Read
Status Flags	{false, false, false, false} (0000)	BACnetStatusFlags	Read
Event State	NORMAL (0)	BACnetEventState	Read
Reliability	NOT_FAULT_DETECTED (0)	BACnetReliability	Read
Out of Service	FALSE (0)	Boolean	Read
Property List		BACnetArray	Read

Rules Enforced:

Present Value = 0 for °C
Present Value = 1 for °F

BACnet® Protocol Implementation Conformance Statement (PICS)

Date: Feb 28, 2019
Vendor Name: Greystone Energy Systems
Product Name: Network Temperature Sensor
Product Model Number: TN
Application Software Version: 1.0
Firmware Revision: 1.0
BACnet® Protocol Revision: 14

Product Description: The TN Greystone Network Temperature Sensor is a smart sensor with native BACnet MS/TP protocol for network communication. It measures local temperature and reports values back to a building automation system (BAS).

BACnet Standardized Device Profile (Annex L): BACnet Application Specific Controller (B-ASC)

BACnet Interoperability Building Blocks Supported (Annex K):

DS-RP-B, DS-RPM-B, DS-WP-B, DM-DDB-B, DM-DOB-B, DM-DCC-B

Segmentation Capability: Not supported

Standard Object Types Supported:

Object Type	Dynamically Creatable	Dynamically Deletable	Optional Properties Supported	Writable Properties
Device	No	No	Location, Description, Max_Master, Max Info Frames	Object_Identifier, Object_Name, Location, Description, APDU_Timeout, Max_Master, Number Of APDU Retires
Analog Input	No	No	Description, Reliability, Device Type	
Analog Value	No	No	Description	Present Value
Binary Value	No	No	Description, Reliability	Present_Value

Data Link Layer Options: MS/TP master (Clause 9),
 Baud rates: 9600, 19200, 38400, 57600, 76800, 115200

Device Address Binding: Not supported

Networking Options: None

Character Set Supported: ISO 10646 (UTF-8)

SPECIFICATIONS

GENERAL

Power Supply 24 Vac/dc $\pm 10\%$ (non-isolated half-wave rectified)

Consumption 25 mA max @ 24 Vdc

Protection Circuitry..... Reverse voltage protected, transient protected

Operating Environment -40 to 60°C (-40 to 140°F), 10 to 95 %RH non-condensing

Wire Material:..... PVC insulated, parallel bonded, 22 AWG

Wire Length: 1.524 m (5')

Probe Material: 304 Series Stainless Steel

Probe Diameter:..... 6 mm (0.236")

Standard Lengths:..... 50, 100, 150, 200, 300, 450 mm (2", 4", 6", 8", 12", 18")

Wiring Connection..... Screw terminal block (14-22 AWG)

Enclosure ABS, UL94-V0, IP65 (NEMA 4X)
 E style includes thread adapter (1/2" NPT to M16) and cable gland fitting

Dimensions 82.5mm W x 76.2mm H x 52.0mm D (3.25" x 3.0" x 2.05")

Protection Class III

Power Source UL 24VAC/DC, 50/60HZ, 25mA, SELV, Class 2

EU Conformity CE

Certification UL 60730 & CSA E60730

UL 2043 / CSA /

ULC S142 Compliant Suitable for Use In Air Handling Spaces in Accordance with Section 300.22, (C) of the National Electrical Code

Purpose of Control Operating Control

Type of Action Type 1

Impulse Voltage 330V

Pollution Degree 2

Country of Origin..... Canada

TEMPERATURE SENSOR

Sensing Element..... 20 K Ω NTC thermistor

Sensor Accuracy..... $\pm 0.2^\circ\text{C}$ ($\pm 0.36^\circ\text{F}$) @ 0 to 70°C (32 to 158°F)

Probe Sensing Range..... -40 to 100°C (-40 to 212°F), 10 to 95 %RH non-condensing

Resolution 0.1°C/°F

BACnet®

Interface..... MS/TP, 2 wire RS-485

Baud Rate 9600, 19200, 38400, 57600, 76800 or 115200 (auto-detect)

Address Range..... 0 to 127 (switch selectable)

Serial Configuration..... 8N1

DIMENSIONS

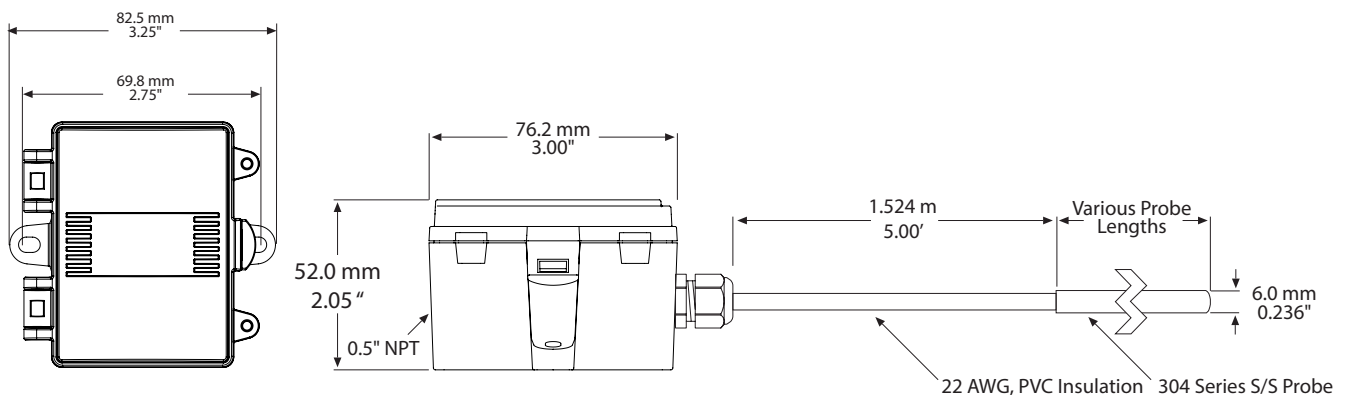

PRINTED IN CANADA