

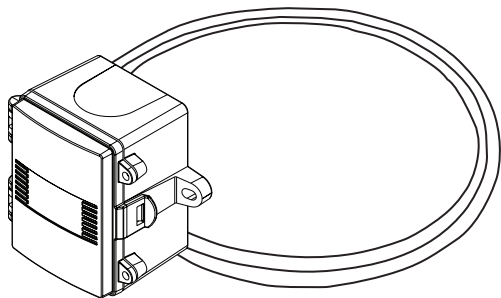

INTRODUCTION

The multi point duct average temperature transmitter incorporates numerous precision sensors at equal distances and encapsulated in a 7.94 mm (0.3125") OD, soft copper probe and is available in various lengths. All probes provide excellent heat transfer, fast response and resist moisture penetration. A transmitter that provides a high accuracy signal with excellent long term stability, low hysteresis and fast response is provided. A compact ABS enclosure with a hinged and gasketed cover is provided for ease of installation.



Features include a -40 to 60°C (-40 to 140°F) temperature measurement range, high accuracy and resolution, and auto-detect baud rate. The network temperature sensor includes network variables for the temperature reading, °C/°F units and a calibration offset.

BEFORE INSTALLATION

Read these instructions carefully before installing and commissioning the temperature sensor. Failure to follow these instructions may result in product damage. Do not use in an explosive or hazardous environment, with combustible or flammable gases, as a safety or emergency stop device or in any other application where failure of the product could result in personal injury. **Follow electrostatic discharge precautions during installation and do not exceed the device ratings.**

MOUNTING

The sensor installs directly into any air duct with several lengths available for a wide range of duct widths/diameters. Select a suitable installation area in the middle of the duct wall. To achieve the best reading, do not place in an area where air stratification may be present. Mount the sensor at least 1.5 m (5') in either direction from elbows, dampers, filters or other duct restrictions. Avoid areas where the sensor is exposed to vibrations or rapid temperature changes.

Once a suitable spot is selected, drill a 9.5 - 12 mm (3/8" - 1/2") hole. Uncoil the copper probe and slide into the drilled hole until the enclosure is flush against the duct. The airflow direction is not important. Secure the enclosure to the duct with #10 x 25 mm (1") self tapping screws (not provided). Tighten screws until the enclosure is tight against the duct and ensure that there is no movement of the enclosure as shown in Figure 1.

A foam gasket is provided on the back of the enclosure that provides a tight seal against any air leaks.

The probe can be easily shaped to fit any duct size but observe a minimum bend radius of 4" to prevent damage to the wire or sensors. Criss-cross the duct multiple times so that the probe covers a large section of the duct. The probe needs to be fastened onto hangers using tube clamps or wire ties. See Figure 2.

Figure 1

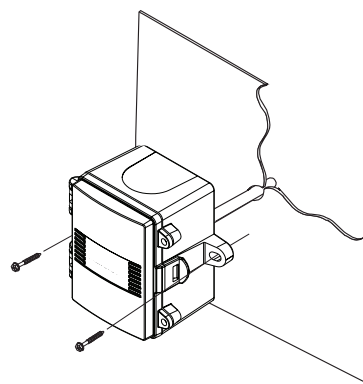

Figure 2

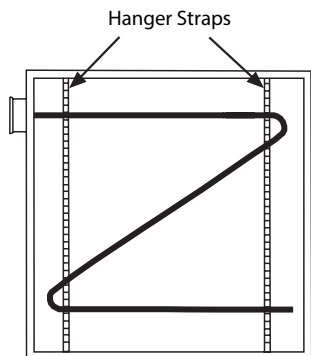

Figure 3

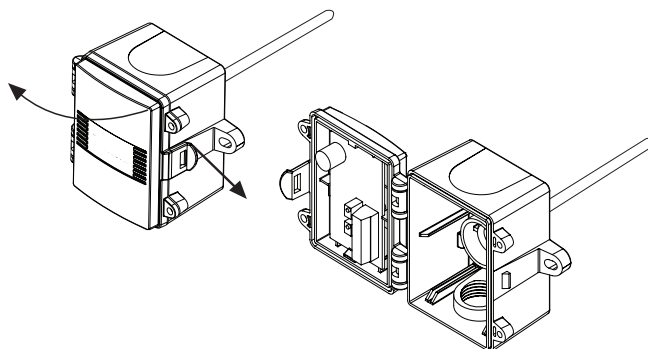

Figure 4

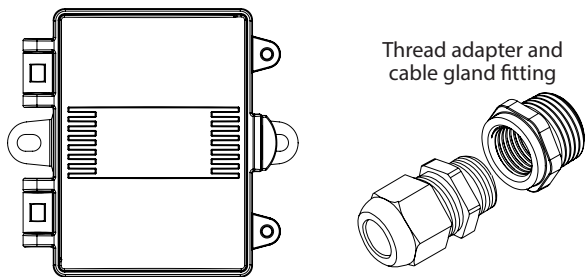
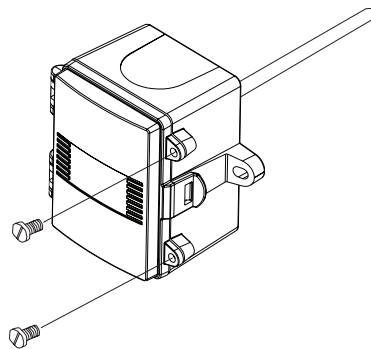

Figure 5



The enclosure has a hinged cover with a latch. Open the cover by pulling slightly on the latch on the right side of the enclosure, at the same time pulling on the cover, as illustrated in Figure 3.

A 1/2" NPT threaded connection hole is provided in the bottom of the enclosure. Screw the EMT connector or cable gland connector in until tight. See figure 4. It is recommended that weatherproof conduit or cable gland fittings be used. The E style enclosure includes a 1/2" NPT to M16 thread adapter and cable gland fitting.

Make wiring connections as per the "Wiring" illustrations below.

Swing door closed until securely latched. For added security, 2 screws are provided that may be installed in the integrated screw tabs. See Figure 5.

WIRING

Deactivate the 24 Vac/dc power supply until all connections are made to the device to prevent electrical shock or equipment damage. Use 14-22 AWG shielded wire for all connections and do not locate the device wires in the same conduit with wiring used to supply inductive loads such as motors. Pull at least six inches of wire into the enclosure and complete the wiring connections according to the wiring diagram. Make all connections in accordance with national and local codes.

Connect the plus DC or the AC voltage hot side to the PWR terminal and the power supply common is connected to the COM terminal. The device has a half-wave power supply so use caution when wiring multiple devices to that the circuit ground point is the same on all devices and the controller. Use caution

Figure 6

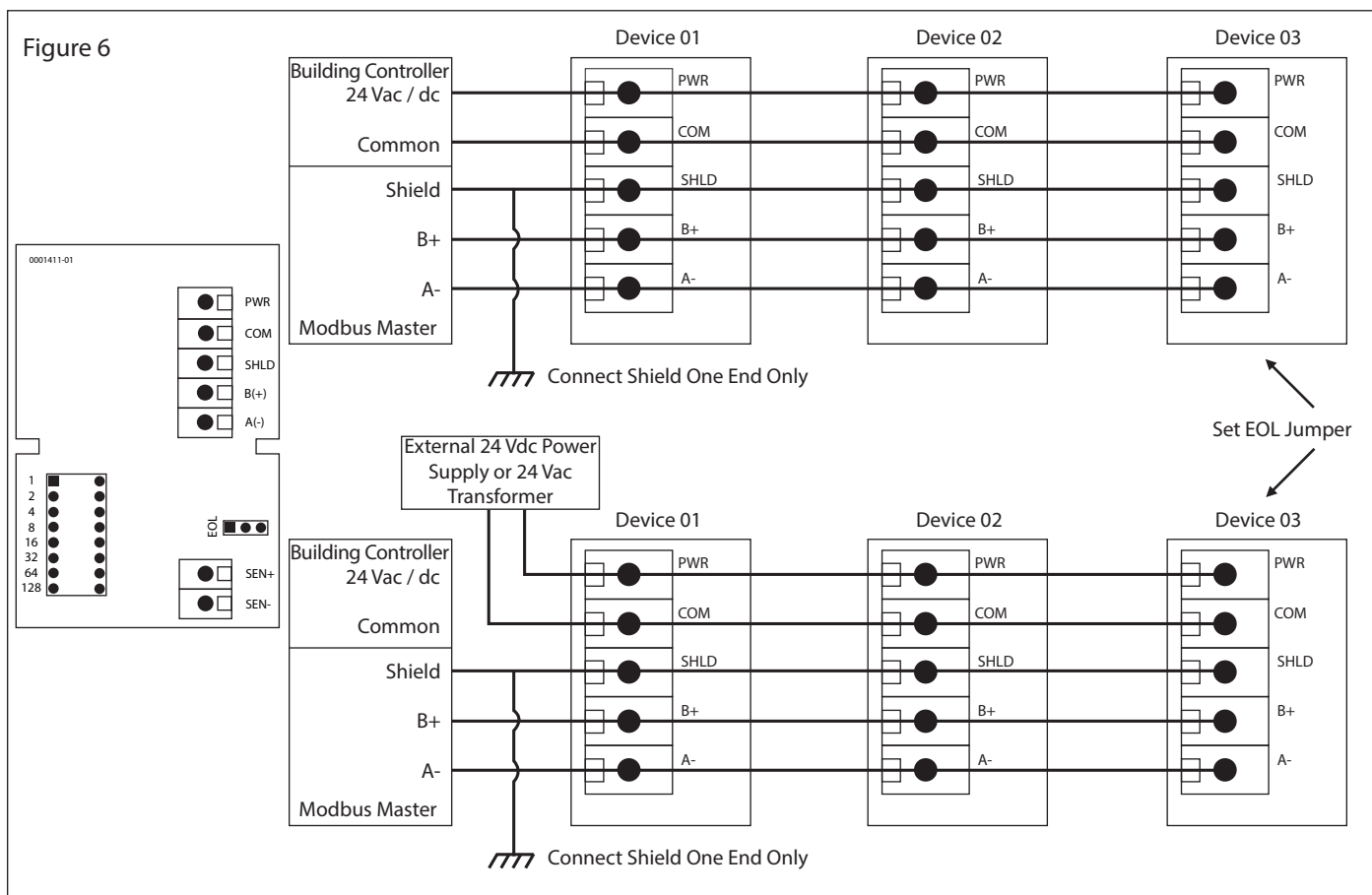

if 24 Vac power is used and one side of the transformer is earth grounded. In general, the transformer should NOT be connected to earth ground when using devices with an RS-485 network connection. The device is reverse voltage protected and will not operate if connected backwards.

Connect the RS-485 network with twisted shield pair to the terminals marked A-, B+, and SHLD (shield) as shown in Figure 6. The positive wire connects to B+ and the negative wire connects to A- and the cable shield must be connected to the SHLD terminals of each device. If the device is connected to the end of the network, and end-of-line (EOL) termination resistor (121 Ω) should be installed in parallel with the A- and B+ terminals. This device includes a network termination jumper and will connect the resistor correctly on the PCB. Simply move the PCB jumper to the EOL position as shown in Figure 7 and no external resistor is required. The ground wire of the shielded pair should be connected to earth ground at the end of the network and the master is not grounded. Do not run bus wiring in the same conduit as line voltage wiring.

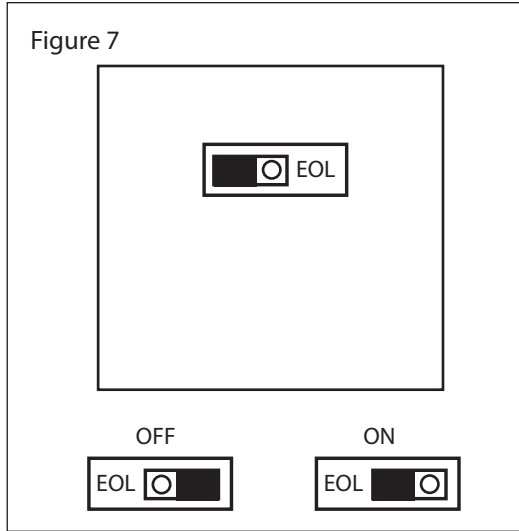

A network segment is a single shielded wire loop run between several devices (nodes) in a daisy chain configuration. The total segment length should be less than 1220 metres (4000 feet) and the maximum number of nodes on one segment is 127. Nodes are any device connected to the loop and include controllers, repeaters and sensors such as the Network Temperature Sensor but does not include the EOL terminators. To install more devices, or to increase the network length, repeaters will be required for proper communication. The maximum daisy chain length (segment) depends on transmission speed (baud rate), wire size and number of nodes. If communication is slow or unreliable, it may be necessary to wire two daisy chains to the controller with a repeater for each segment.

LED OPERATION

In normal operating mode, the LED blinks for 30 seconds on setup at 1 Hz, then indicates communication activity. If the sensor reading is out of range then the LED stays on constantly to indicate a defect or over / under range condition.

NETWORK COMMUNICATION

The device parameters must be set before connection to the network and will ensure that each device has a unique Modbus address. The PCB DIP switch is used to set the Modbus address (1-255) as shown in Figure 7.

Note that the Modbus network baud rate may be 9600, 19200, 38400, 57600, 76800, or 115200 and is auto-detected on start-up.

The sensor operates as a slave. It will not communicate unless a master is connected to the network and sends a request for information, then the slave will answer. If the device does not communicate properly, first check that the communication wires are not reversed. Then check that the slave address has a unique setting for the network segment it is connected to. Finally, verify that the device parity bit, stop bit, and RTU mode CRC polynomial are correct for the network it is connected to.

Figure 8

DIP Switch Position								Modbus Address
128	64	32	16	8	4	2	1	
OFF	OFF	OFF	OFF	OFF	OFF	OFF	ON	1
OFF	OFF	OFF	OFF	OFF	OFF	ON	OFF	2
OFF	OFF	OFF	OFF	OFF	OFF	ON	ON	3
OFF	OFF	OFF	OFF	OFF	ON	OFF	OFF	4
↓	↓	↓	↓	↓	↓	↓	↓	↓
ON	ON	ON	ON	ON	ON	ON	OFF	254
ON	ON	ON	ON	ON	ON	ON	ON	255

1

2

4

8

16

32

64

128

OFF ON

MODBUS PROTOCOL

This section describes the implementation of the Modbus protocol. It is intended to assist control system programmers who may need to add support to their systems to communicate with this device. The device communicates on standard Modbus networks using RTU mode transmission. It operates as a slave device (address from 1 to 255) and expects a Modbus master device to transmit queries, which it will answer.

RTU MESSAGE FORMAT

Modbus Framing	8 bit binary
Data Bits	start bits --- 1, data bits --- 8, parity bits --- none, stop bits --- 1
Baud Rate	9600, 19200, 38400, 57600, 76800, or 115200 (auto-detect)
Duplex	Half duplex
Error Checking	Cyclical Redundancy Check (CRC) CRC-16 Reversed --- polynomial $x^{16}+x^{15}+x^2+x^0$ (0xA001)
Latency	More than 3.5 characters --- minimum

RTU FRAMING SUPPORT AND BIT SEQUENCES

Start	1	2	3	4	5	6	7	8	Stop
-------	---	---	---	---	---	---	---	---	------

MODBUS REGISTER ADDRESSING

Modbus Address	Typical Offset	Units	Data Type	Access	Notes
40001	+0	°C/°F	Word	Read	16-bit integer, TEMPERATURE_VALUE x 10 Multiplier = 10 -400 to 1000 for -40.0 to 100.0°C, -400 to 2120 for -40.0 to 212.0°F
40002	+1	°C/°F	Word	Read Write	16-bit integer, TEMPERATURE_OFFSET x 10 Multiplier = 10 -50 to 50 for -5.0 to 5.0°C, -100 to 100 for -10.0 to 10.0°F
40003	+2		Word	Read Write	16-bit integer, TEMPERATURE_UNITS 0 = °C, 1 = °F

RTU FUNCTION CODES

0x03 --- Read holding registers

Query

Slave address (0x01 to 0xFF)	Function code (0x03)	Starting address MSB	Starting address LSB	Quantity of Registers MSB	Quantity of registers MSB	CRC LSB	CRC MSB
---------------------------------	----------------------	----------------------	----------------------	---------------------------	---------------------------	---------	---------

*Starting address = 0x0000 to 0xFFFF, Quantity of registers = 0x0000 to 0x007D

Response

Slave address (0x01 to 0xFF)	Function code (0x03)	Byte count 2N	Register value MSB	Register value LSB	...	CRC LSB	CRC MSB
---------------------------------	----------------------	------------------	--------------------	--------------------	-----	---------	---------

*N = Quantity of registers

0x06 --- Write single register

Query

Slave address (0x01 to 0xFF)	Function code 0x06	Register address MSB	Register address LSB	Register value MSB	Register value LSB	CRC LSB	CRC MSB
---------------------------------	--------------------	----------------------	----------------------	--------------------	--------------------	---------	---------

Response

Slave address (0x01 to 0xFF)	Function code 0x06	Register address MSB	Register address LSB	Register value MSB	Register value LSB	CRC LSB	CRC MSB
---------------------------------	--------------------	----------------------	----------------------	--------------------	--------------------	---------	---------

*Register address = 0x0000 to 0xFFFF, Registers value = 0x0000 to 0xFFFF

Exception Response

Slave address (0x01 to 0xFF)	Function code + 0x80	Exception code 0x01, 0x02 or 0x03	CRC LSB	CRC MSB
---------------------------------	-------------------------	--------------------------------------	------------	------------

*An exception response is only returned if the CRC is correct
Exception code 01 --- illegal function, 02 --- illegal address, 03 --- illegal data value

The RTU function codes supported are shown below.

Note that the registers may be read individually or all registers may be read at the same time as shown below.

To read all registers with one query...

0x03 --- Read ALL REGISTERS

Query

Slave address (0x01 to 0xFF)	0x03	0x00	0x00	0x00	0x03	CRC LSB	CRC MSB
---------------------------------	------	------	------	------	------	------------	------------

Response

Slave address (0x01 to 0xFF)	0x03	0x06	Register value MSB	Register value LSB	...	CRC LSB	CRC MSB
---------------------------------	------	------	-----------------------	-----------------------	-----	------------	------------

0x03 --- Read TEMPERATURE_VALUE

Query

Slave address (0x01 to 0xFF)	0x03	0x00	0x00	0x00	0x01	CRC LSB	CRC MSB
---------------------------------	------	------	------	------	------	------------	------------

Response

Slave address (0x01 to 0xFF)	0x03	0x02	Register value MSB	Register value LSB	CRC LSB	CRC MSB
---------------------------------	------	------	-----------------------	-----------------------	------------	------------

*Register value = 0xFE70 to 0x03E8, corresponding to -40.0 to 100.0°C (multiplier = 10)
or = 0xFE70 to 0x0848, corresponding to -40.0 to 212.0°F (multiplier = 10)

The temperature value is either in °C (default) or °F depending on the value of the TEMPERATURE_UNITS register.

This register has a multiplier of 10, the application must divide by 10 to obtain the correct value.

0x03 --- Read TEMPERATURE_OFFSET

Query

Slave address (0x01 to 0xFF)	0x03	0x00	0x01	0x00	0x01	CRC LSB	CRC MSB
---------------------------------	------	------	------	------	------	------------	------------

Response

Slave address (0x01 to 0xFF)	0x03	0x02	Register value MSB	Register value LSB	CRC LSB	CRC MSB
---------------------------------	------	------	-----------------------	-----------------------	------------	------------

*Register value = 0xFFCE to 0x0032, corresponding to -5.0 to 5.0°C (multiplier = 10)
or = 0xFF9C to 0x0064, corresponding to -10.0 to 10.0°F (multiplier = 10)

The temperature offset value is either in °C (default) or °F depending on the value of the TEMPERATURE_UNITS register.

This register has a multiplier of 10, the application must divide by 10 to obtain the correct value.

0x03 --- Read TEMPERATURE_UNITS

Query

Slave address (0x01 to 0xFF)	0x03	0x00	0x02	0x00	0x01	CRC LSB	CRC MSB
---------------------------------	------	------	------	------	------	------------	------------

Response

Slave address (0x01 to 0xFF)	0x03	0x02	Register value MSB	Register value LSB	CRC LSB	CRC MSB
---------------------------------	------	------	-----------------------	-----------------------	------------	------------

*Register value = 0x0000 corresponding to °C
 = 0x0001 corresponding to °F

0x06 --- Write TEMPERATURE_OFFSET

Query

Slave address (0x01 to 0xFF)	0x06	0x00	0x01	Register value MSB	Register value LSB	CRC LSB	CRC MSB
---------------------------------	------	------	------	-----------------------	-----------------------	------------	------------

Response

Slave address (0x01 to 0xFF)	0x06	0x00	0x01	Register value MSB	Register value LSB	CRC LSB	CRC MSB
---------------------------------	------	------	------	-----------------------	-----------------------	------------	------------

*The register is used to add or subtract an offset to the temperature value if necessary to confirm to a local reference.

Register value = 0xFFCE to 0x0032, corresponding to -5.0 to 5.0°C (multiplier = 10)
 or = 0xFF9C to 0x0064, corresponding to -10.0 to 10.0°F (multiplier = 10)

The temperature offset value is either in °C (default) or °F depending on the value of the TEMPERATURE_UNITS register.

This register has a multiplier of 10, the application must divide by 10 to obtain the correct value. The operating temperature units (°C or °F) for the device should be selected first, and then add any offset if necessary.

0x06 --- Write TEMPERATURE_UNITS

Query

Slave address (0x01 to 0xFF)	0x06	0x00	0x02	0x00	Register value LSB	CRC LSB	CRC MSB
---------------------------------	------	------	------	------	-----------------------	------------	------------

Response

Slave address (0x01 to 0xFF)	0x06	0x00	0x02	0x00	Register value LSB	CRC LSB	CRC MSB
---------------------------------	------	------	------	------	-----------------------	------------	------------

*Register value = 0x0000 = sets the device to °C operation
 = 0x0001 = sets the device to °F operation

Exception response

Slave address (0x01 to 0xFF)	Function code + 0x80	Exception code * 0x01, 0x02 or 0x03	CRC LSB	CRC MSB
---------------------------------	-------------------------	----------------------------------------	------------	------------

*An exception response is only returned if the CRC is correct
 Exception code 01 --- illegal function
 Exception code 02 --- illegal address
 Exception code 03 --- illegal data value

SPECIFICATIONS

GENERAL

Power Supply	24 Vac/dc \pm 20% (non-isolated half-wave rectified)
Consumption	10 mA max @ 24 Vdc
Protection Circuitry.....	Reverse voltage protected, transient protected
Operating Environment	-40 to 50°C (-40 to 122°F), 5 to 95 %RH non-condensing
Wiring Connection.....	Screw terminal block (14 to 22 AWG)
Enclosure	ABS, UL94-V0, IP65 (NEMA 4X)
Dimensions.....	82.5mm W x 76.2mm H x 52.0mm D (3.25" x 3.0" x 2.05")
Probe Material	Soft copper
Probe Diameter	7.94 mm (0.3125")
Probe Lengths	1800, 3600, 6100, 7200 mm (6', 12', 20', 24')
Country of Origin.....	Canada

TEMPERATURE SENSOR

Temperature Sensor	20 K Ω NTC thermistor
Sensor Accuracy.....	\pm 0.2°C (\pm 0.36°F) @ 0 to 70°C (32 to 158°F)
Probe Sensing Range.....	-20 to 60°C (-4 to 140°F)
Resolution	0.1°C/°F

MODBUS COMMUNICATION

Modbus Interface	MS/TP (RTU), 2 wire RS-485
Baud Rate	9600, 19200, 38400, 57600, 76800, or 115200 (auto-detect)
Address Range.....	1 to 255 (switch selectable)
Serial Configuration.....	8N1
Error Checking.....	CRC-16 reverse (A001)

DIMENSIONS

