

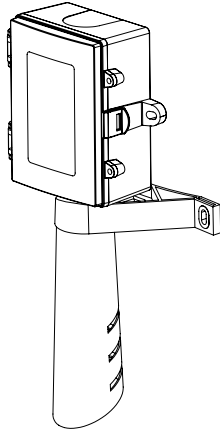

Outside High Limit Thermostat with Sun and Windshield

THOB Series - Installation Instructions



INTRODUCTION

The single point outside air high limit thermostat incorporates a precision thermistor temperature sensor and provides a Form C relay output (NO/NC) with an adjustable setpoint. All probes are constructed to provide excellent heat transfer, fast response and are potted to resist moisture penetration. A sun and wind shield is integrated into a hinged and gasketed weatherproof Polycarbonate enclosure.

BEFORE INSTALLATION

Read these instructions carefully before installing and commissioning the thermostat. Failure to follow these instructions may result in product damage. Do not use in an explosive or hazardous environment, with combustible or flammable gases, as a safety or emergency stop device or in any other application where failure of the product could result in personal injury. **Do not exceed the device ratings.**

MOUNTING

Select a suitable mounting spot on an exterior wall where the temperature sensor is best protected from direct exposure to sunlight, wind, etc. Preferably on a north facing wall. Do not mount the sensor near opening windows, supply/exhaust air louvres or other known air disturbances. Avoid areas where the sensor is exposed to vibrations or rapid temperature changes.

The temperature sensor provides a connection hole for 1/2" conduit. Run a length of conduit through exterior wall and seal. Use 14-24 AWG shielded wiring for all connections and do not locate the device wires in the same conduit with wiring used to supply inductive loads such as motors. Make all connections in accordance with national and local codes.

The temperature sensor installs directly on an exterior wall using the two integrated mounting holes provided on the enclosure. Select the best mounting technique based on the exterior wall material. The two mounting holes are suitable for a #10 size screw (not supplied). The sensor fitting must be pointing down. See Figure 1.

The enclosure has a hinged cover with a latch. Open the cover by pulling slightly on the latch on the right side of the enclosure. At the same time pulling on the cover, as illustrated in Figure 2.

A 1/2" NPT connection hole is provided in the back of the enclosure. Connect the EMT connector with a locknut. See Figure 3. It is recommended that a weatherproof conduit fitting be used. Make wiring connections as per the "wiring" illustrations on Page 2.

Swing door closed until securely latched. For added security, two screws are provided that may be installed in the integrated screw tabs. See Figure 4.

Figure 1

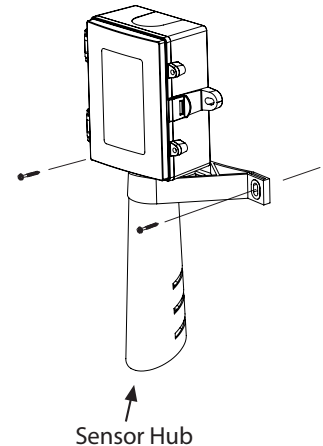

Figure 2

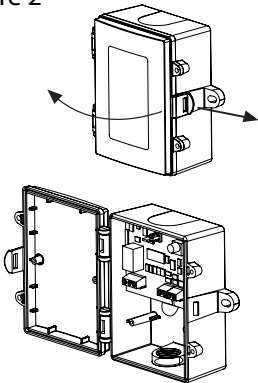

Figure 3

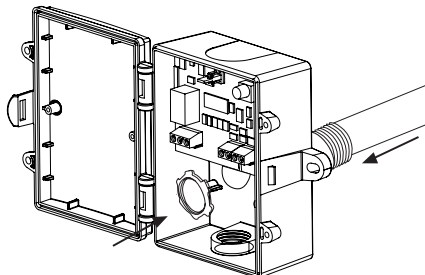

Figure 4

