

#### INTRODUCTION

The room temperature sensor is designed for temperature measurement of occupied spaces and utilizes a precision sensor encapsulated in PVC insulated cable with various thermistors available. The sensor is housed within an attractive, low profile wall mount enclosure.

#### BEFORE INSTALLATION

Read these instructions carefully before installing and commissioning the temperature sensor. Failure to follow these instructions may result in product damage. Do not use in an explosive or hazardous environment, with combustible or flammable gases, as a safety or emergency stop device or in any other application where failure of the product could result in personal injury. **Do not exceed device ratings.**

#### MOUNTING

The room temperature sensor installs directly to an electrical wall box, or can be mounted directly to the wall. The temperature sensor should be mounted five feet from the floor of the area to be controlled. Do not mount the sensor near doors, opening windows, supply air diffusers or other known air disturbances. Avoid areas where the sensor is exposed to vibrations.

Begin by removing the cover. Grasp the bottom of the cover and pull outward from the backplate as shown in Figure 1. Set the cover aside. Do not remove the PCB from the enclosure base.

Feed at least 6 inches of wire through the wall and out of the junction box. Feed connection wires through the center hole on the backplate and the PCB, then secure the backplate to the electrical box or wall with suitable screws (not supplied) as shown in Figure 2. The mounting holes allow for up/down and side to side movement to compensate for unlevel electrical box installation.

Make wire connections as per the "Wiring" section on Page 2.

Re-install decorative cover by placing the top of the cover into the cover holders on the top of the backplate and snapping the bottom into place.

Two 1/16" Allen Key set screws are provided on the bottom of the enclosure to add security and lock cover in place. To engage, insert Allen Key and turn counter-clock-wise 2-3 rotations. As seen in Figure 3.

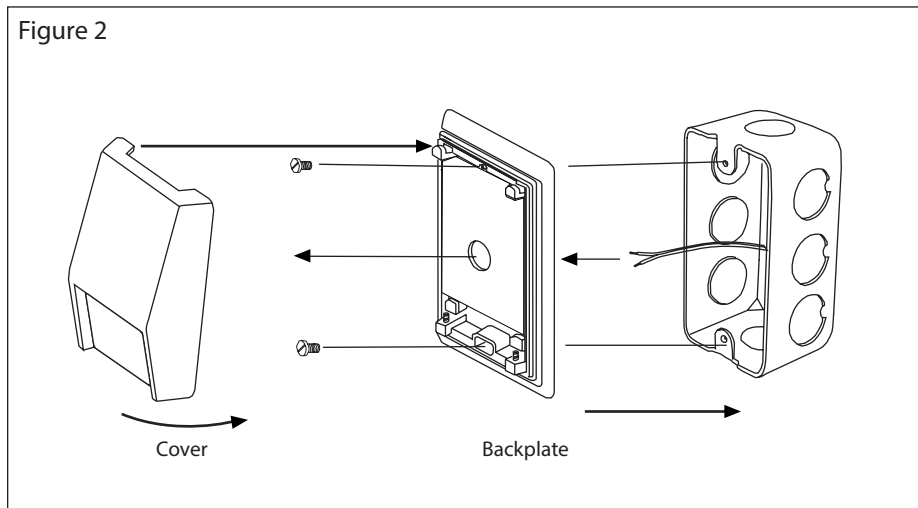
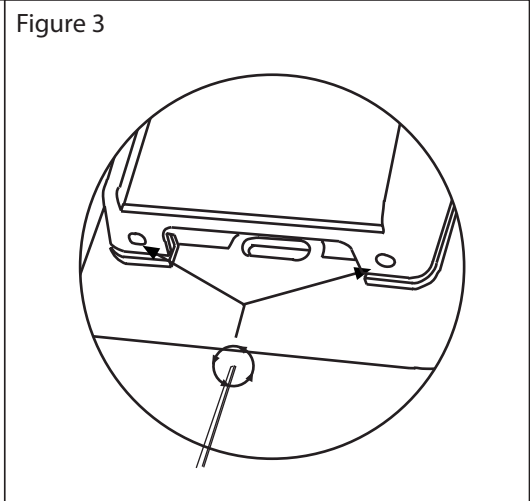
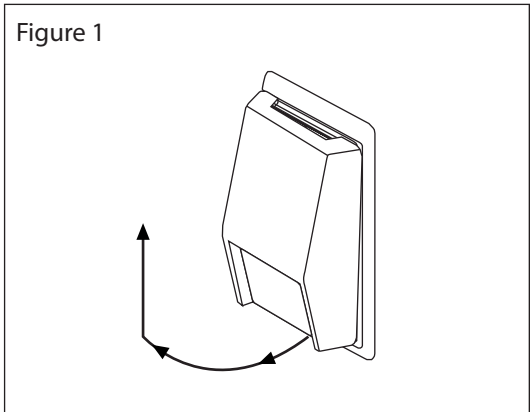

## WIRING

- Follow proper electrostatic discharge (ESD) handling procedures when installing the device or equipment damage may occur.
- Use 22 AWG shielded wiring for all connections and do not locate the device wires in the same conduit with wiring used to supply inductive loads such as motors. Connect the cable shield to ground at the controller only. Make all connections in accordance with national and local codes.
- Connector layout is shown in Figure 5. The diagram shown includes all options, if an option is not ordered, the connector will not be present.

Figure 4 2 Wire Termination for Thermistor or RTD

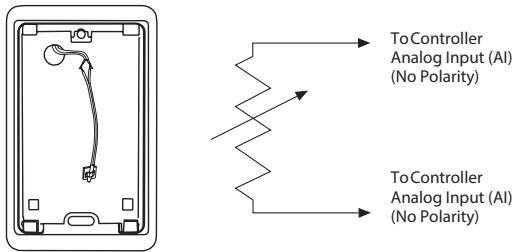

3 Wire Termination for Thermistor or RTD

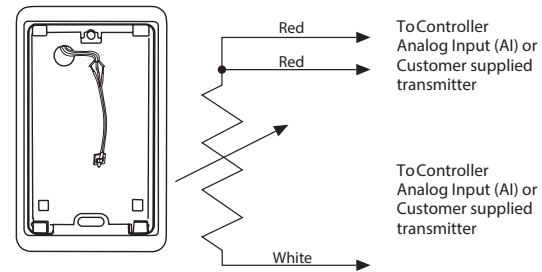
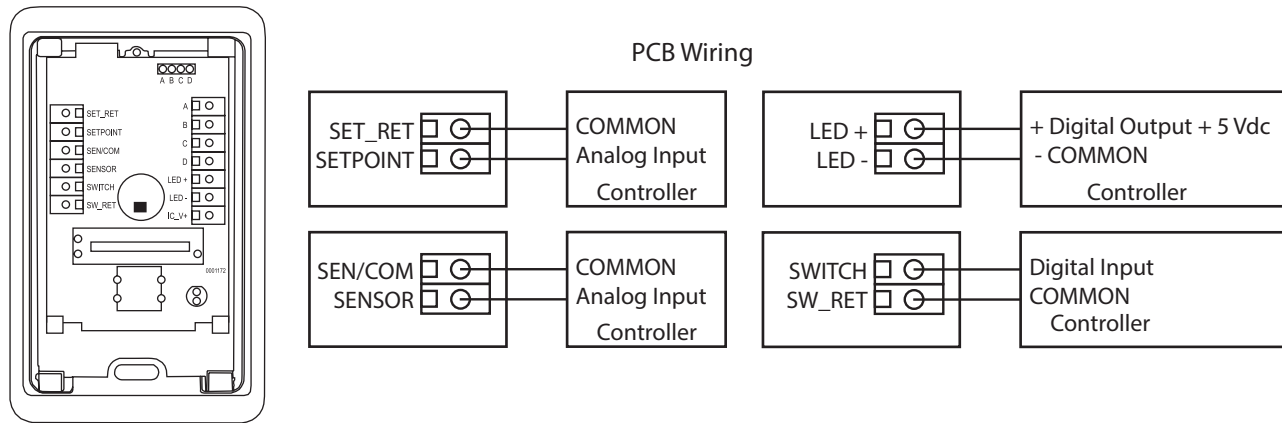

Figure 5



## TYPICAL WIRE RESISTANCE VALUES

When using low resistance sensors (i.e. 100  $\Omega$  RTD), long wire runs can add significant error to the readings. Use the following chart to determine errors due to wire resistance or consider using 1000  $\Omega$  sensor or a transmitter for better accuracy. Locate the type of wire being used. Multiply the total length of the wire (distance from the controller to the sensor and back) by the number found in the following chart for total resistance.

GAGE WIRE TYPE	18 AWG	22 AWG	24 AWG
STRANDED (OHMS/FOOT)	5.85 m $\Omega$	14.75 m $\Omega$	23.29 m $\Omega$
SOLID (OHMS/FOOT)	6.4 m $\Omega$	15.85 m $\Omega$	25.72 m $\Omega$

## SPECIFICATIONS

Sensor Type .....	<b>Thermistors:</b> 1801 $\Omega$ , 3K, 10K (type 2 & 3), 20K & 100K, IC Sensors
	<b>Ni RTD's:</b> 100 $\Omega$ , 1K PT, 1K $\Omega$ Ni
Temperature Range .....	-20 to 70°C (-4 to 158°F)
Cable Material .....	PVC insulated, parallel bonded (100 $\Omega$ , IC sensors - twisted 3 wire)
Wiring Connections .....	Pigtail, 2 or 3 wire
Enclosure .....	White ABS, IP20 (NEMA 1)
Dimensions .....	70 W x 114 H x 30mm D (2.75" x 4.5" x 1.2")
Country of Origin .....	Canada

## DIMENSIONS

