

#### INTRODUCTION

The SC-675 series split-core current sensor monitors line current for electrical loads such as pumps, conveyors, machine tools or fans and outputs an analog true RMS 4-20 mA signal to represent the load current. The SC-675 split-core series opens to allow ease of installation on existing electrical cables.

The sensor is loop powered and requires an external 15-30 Vdc power supply. The power supply must be  $10 \text{ Vdc} + (R_{load} \times 20 \text{ mA})$  where  $R_{load}$  is the input resistance of the device measuring the signal. So if  $R_{load}$  is  $250 \Omega$  the minimum power supply is 15 Vdc. The measured AC line current can be calculated as  $I_{line} = (I_{loop} - 4 \text{ mA}) \times I_{range} / 16$ . The device is factory calibrated to  $< \pm 2\%$  FSO and features either three jumper-selectable current ranges or fixed range models.

The sensors are typically used to monitor motor operation and can be used to determine motor failure, belt loss, machine feed rates or tool wear.

#### \*WARNING\*

- **Electric shock hazard, use caution**
- Disconnect and lock out power before installation
- Follow national and local electrical codes
- Read and understand these instructions before installing
- Installation only by qualified electrical personnel
- Do not rely on this device to indicate line power
- Only install this device on insulated conductors
- Only install on 600 Vac maximum conductors
- Do not use this device for life-safety applications
- Do not install in hazardous or classified locations
- Install this product in a suitable electrical enclosure
- **Failure to follow these instructions will result in death or serious injury**

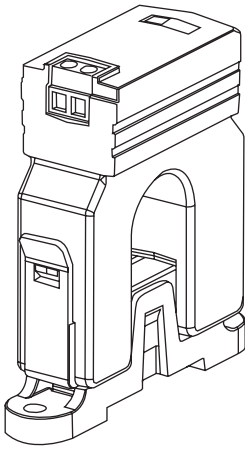

#### INSTALLATION

**Read all warnings before beginning installation of this device.** Ensure the selected device has the correct ratings for your application. Set the range switch to the desired range. See Figure 1. The SC-652-2, 5, and 200 have one fixed range. See Figure 2. **Disconnect and lock out power.** Mount the sensor with two screws through the base or snap onto a standard DIN mounting rail.

The base has an integrated mounting tab to allow either screw mounting to a surface or spring mounting to a DIN rail.

To mount the device to a flat surface, select an area that will allow side and top access to wire the device. If pre-drilling is required, the device may be used to mark holes. See Figure 3. The mounting holes in the base will accommodate up to a #10 size screw (Not supplied). See Figure 3.

For DIN rail mounting, hook one side to the DIN rail and snap onto the rail. See Figure 4.

For ease of installation of either screw or DIN rail mounting, the base may be removed from the sensor, installed and the sensor inserted.

Figure 4

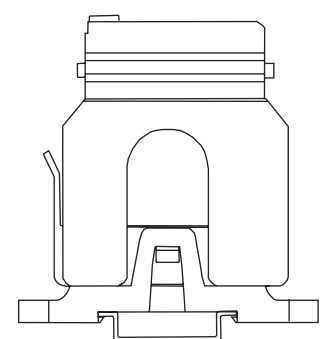
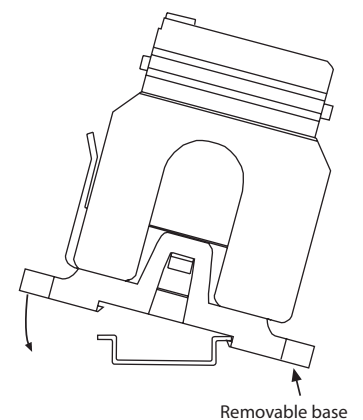
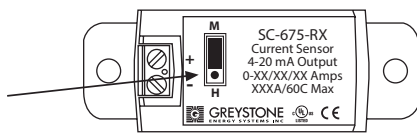
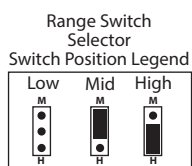

Figure 1



SC-675-R1 Ranges  
 Low (L) = 0 to 10 Amps  
 Mid (M) = 0 to 20 Amps  
 High (H) = 0 to 50 Amps

SC-675-R2 Ranges  
 Low (L) = 0 to 50 Amps  
 Mid (M) = 0 to 100 Amps  
 High (H) = 0 to 150 Amps

Figure 2

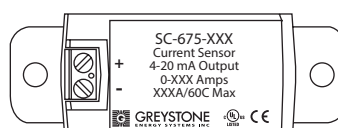

SC-675, 2, 5, & 200 Ranges  
 No Setup is required

Figure 3

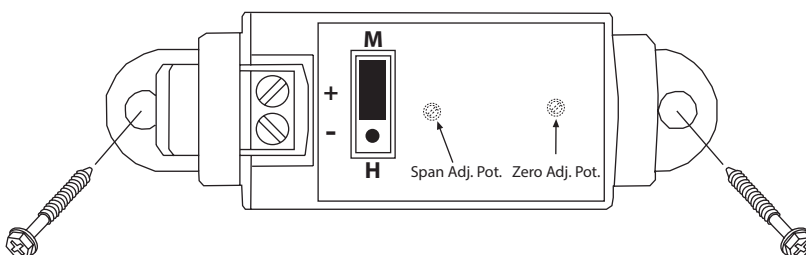

The SC-675 may be opened by slightly pulling the tab and pulling upward and swiveling the device. (See Figure 5). Place the monitored conductor (must be insulated) through the sensor hole and close the sensor until snapped into place. See Figure 6.

Observe polarity and wire the output to the controller. Use 14-22 AWG shielded wiring for all connections and do not locate the device wires in the same conduit with wiring used to supply inductive loads such as motors. Make all connections in accordance with national and local codes. See Figure 7. Ensure the controller scale matches the sensed range. See specifications for model ranges. Reconnect the power.

### APPLICATION

The SC-675 series are factory calibrated to operate within  $\pm 2\%$  of FSO. If field calibration is required or a custom measurement range is desired, simply peel back the top label to expose the calibration pots. See Figure 3. The adjustment pots set the current zero (4 mA) and span (20 mA) of the device and may be adjusted by about  $\pm 20\%$  of FSO. Repeat each adjustment until both are acceptable.

For applications with load currents exceeding the sensor current ranges use an external CT to reduce the current to an acceptable value. For example, to measure a 500 Amp load current, use a 500A:5A CT and wrap the CT secondary through the SC-675-5 so the sensor output will be 4-20 mA = 0-500 Amps.

For applications with small load currents (such as less than 2 Amps), wrap the monitored conductor through the sensor aperture several times to increase the current measured by the sensor. For example, to measure 0-1 Amp with a SC-675-5, wrap the conductor through the sensor aperture 5 times so the sensor output will be 4-20 mA = 0-1 Amp.

For external CT or multiple wrap applications, ensure the controller is scaled accordingly to obtain correct readings.

For any application with multiple wraps, note that the SC-675 maximum current rating must be divided by the number of wraps. For example, with one wrap the maximum current is 100 Amps for the 50 Amp range, with 5 wraps the maximum current is  $100/5 = 20$  Amps. Ensure the load current is  $< 20$  Amps or the device may overheat and be damaged.

Note: these may not be practical applications, select the correct device for the current range required.

### SPECIFICATIONS

Measurement Range.....	<b>SC-675-2:</b> 0-2 Amps <b>SC-675-5:</b> 0-5 Amps <b>SC-675-R1:</b> 0-10/20/50 Amps <b>SC-675-R2:</b> 0-50/100/150 Amps <b>SC-675-200:</b> 0-200 Amps
Maximum Input Current.....	<b>SC-675-2:</b> 10 Amps continuous <b>SC-675-5:</b> 15 Amps continuous <b>SC-675-R1:</b> 3x range continuous <b>SC-675-R2:</b> 2x range continuous <b>SC-675-200:</b> 250 Amps Continuous
Accuracy .....	<b>SC-675-R1/R2:</b> $\pm 2\%$ FSO (5 to 100% of range) <b>SC-675-2,5 &amp; 200:</b> $\pm 1\%$ FSO (5 to 100% of range)
Signal Output.....	4-20 mA
Sensor Power .....	15 to 30 Vdc (loop-powered)
Insulation Class .....	600 Vac, insulated conductors
Frequency .....	50/60 Hz
Response Time .....	500 mS typical, 0 to 90%
Output Load .....	250 $\Omega$ typical
Maximum Load .....	>600 $\Omega$ @ 24 Vdc
Operating Temperature.....	-15 to 60°C (5 to 140°F)
Operating Humidity .....	5 to 90 %RH non-condensing
Terminal Block .....	14 to 22 AWG
Dimensions.....	76mm W x 79mm H x 24.9mm D (3" x 3.1" x 0.98")
Sensor Aperture.....	20.3mm (0.8")
Enclosure Material.....	ABS/PC, UL94 V-0
Agency Approvals .....	cULus Listed
Country of Origin.....	Canada

### DIMENSIONS

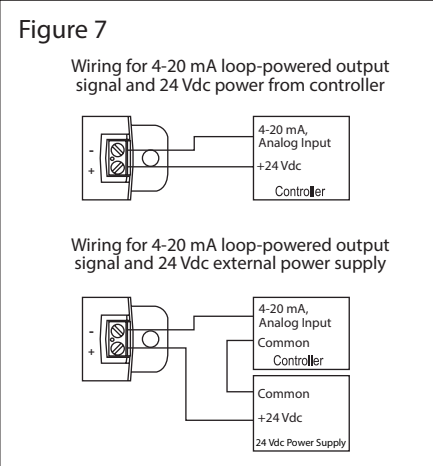
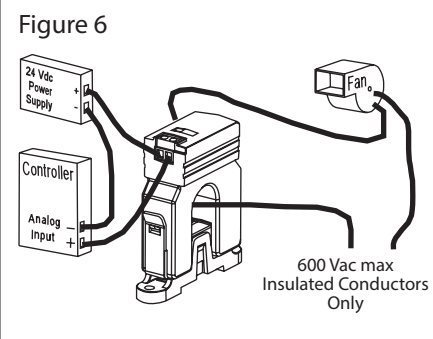
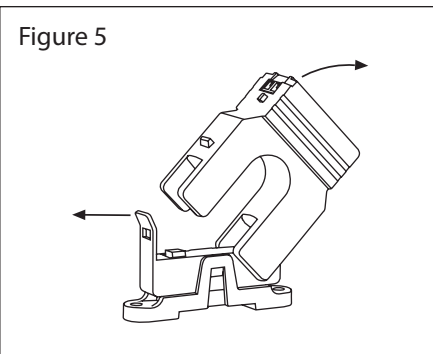
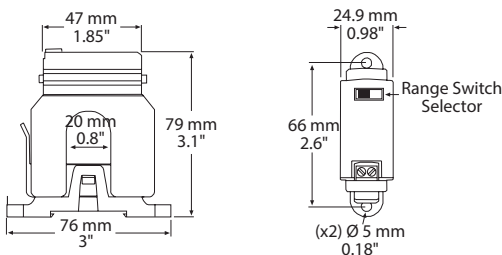

SC-675-R1 Factory Calibrated Ranges      SC-675-R2 Factory Calibrated Ranges

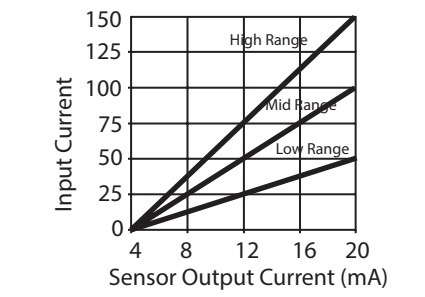
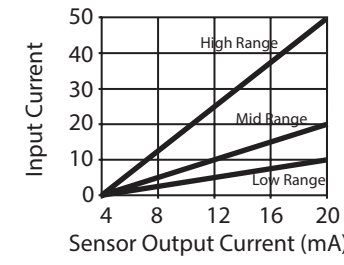

SC-675-2/5 Factory Calibrated Ranges

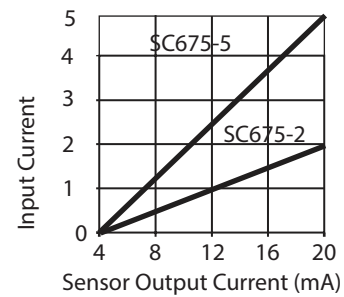

SC-675-200 Factory Calibrated Range

