

INTRODUCTION

The room pressure transmitter is used to measure differential pressure in the range of 0.125 to 1"wc or 30 to 250 Pa. It combines precision high sensitivity silicon sensing capabilities and the latest ASIC technology to substantially reduce offset errors due to changes in temperature, stability to warm up, long term instability and position sensitivity. It is ideal for monitoring pressure for air or other clean inert gas. It features field selectable bi-directional pressure ranges and output signal types for the most flexible application. The device has an on-board auto-zero function, backlit LCD and alarm function with silence switch.

BEFORE INSTALLATION

Read these instructions carefully before installing and commissioning the room pressure transmitter. Failure to follow these instructions may result in product damage. Do not use in an explosive or hazardous environment, with combustible or flammable gases, as a safety or emergency stop device or in any other application where failure of the product could result in personal injury. Take electrostatic discharge precautions during installation. **Do not exceed the device ratings.**

MOUNTING

The room pressure transmitter mounts directly on a wall or onto an electrical wall box. For the most accurate results, units should be mounted on an inside wall to a wall box five feet from the floor. Do not mount the sensor near doors, opening windows, supply air diffusers, or other known air disturbances. Avoid areas where the sensor is exposed to vibrations or rapid temperature changes. To prevent erroneous readings due to air disturbances within the wall cavity, seal the conduit leading to the junction box.

The cover is hooked to the base at the top edge and must be removed from the bottom edge first. Use a small Phillips screwdriver to loosen the security screw as shown in Figure 1. (Complete removal is not required). Use a screw driver to carefully pry each bottom corner if necessary. Tip the cover away from the base and sit it aside as shown in Figure 2.

The PCB must be removed from the base to access the mounting holes. Follow usual anti-static procedures when handling the PCB and be careful not to touch the sensors. The PCB is removed by pressing the enclosure base to unsnap the latch near the bottom edge, then the PCB can be lifted out of the base as shown in Figure 3.

Set the PCB aside until the base is mounted on the wall. For added protection, place the PCB in the supplied anti-static bag.

Mount the base by screwing it to an electrical box or directly to the wall as shown in Figure 4.

After the base is screwed to an electrical box or the wall using the appropriate holes, remove the PCB from the anti-static bag, feed connection wires through center hole and place the top of the PCB into the PCB holders on the backplate and snap the bottom of the PCB into place as shown in Figure 4.

Make wire connections as per the Wiring Illustrations on Page 2 and install decorative cover by placing the top of the cover into the cover holder on the top of the backplate and snapping the bottom into place as shown in Figure 4. Tighten security screw with a screwdriver.

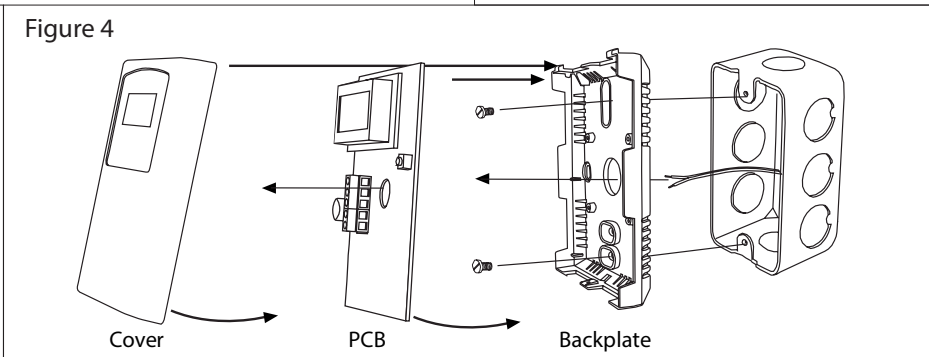
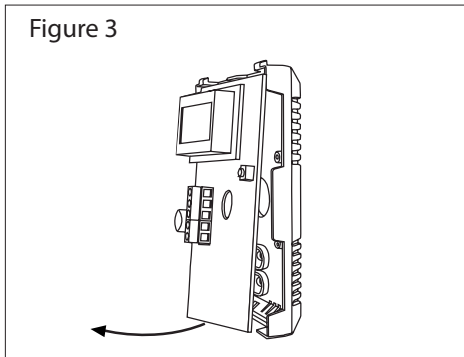
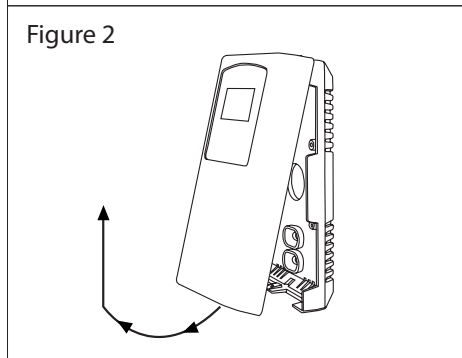
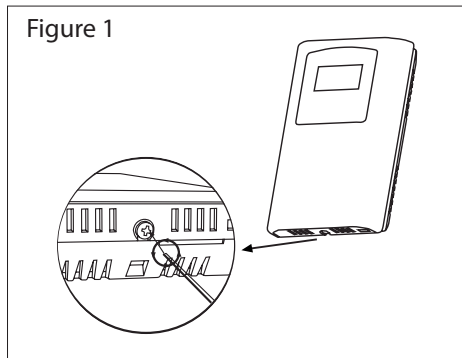

HARDWARE SETUP

The analog output type must be set before the device is connected. Slide the PCB OUTPUT switch to either Vdc or mA for the required output signal type, either 0-5/0-10 Vdc or 4-20 mA. Operating parameters may be set via the menu after the device is connected.

WIRING

- Disconnect the power supply before making any connections to prevent electrical shock or equipment damage. Make all connections in accordance with national and local electrical codes.
- The transmitter has standard screw block connectors. Use shielded twisted pair wiring of at least 22 AWG for all connections and do not run device wires in the same conduit with wiring used to supply inductive loads such as motors.
- This is a 3 wire sourcing device. Connect the positive dc or the ac voltage hot side (24 Vac/dc $\pm 10\%$) to the POWER terminal.
- The supply connection is connected to the COMMON terminal. The device is reverse voltage protected and will not operate if connected backwards. It has a half-wave rectified power supply common is the same as the signal common. Several devices may be connected to one power supply and the output signals all share the same common.
- Use caution when grounding the secondary of a transformer or when wiring multiple devices to ensure the ground point is the same on all devices and the controller.
- The analog output is available on the PRES OUT terminal. The signal is switch selectable for either voltage or 4-20 mA active output.

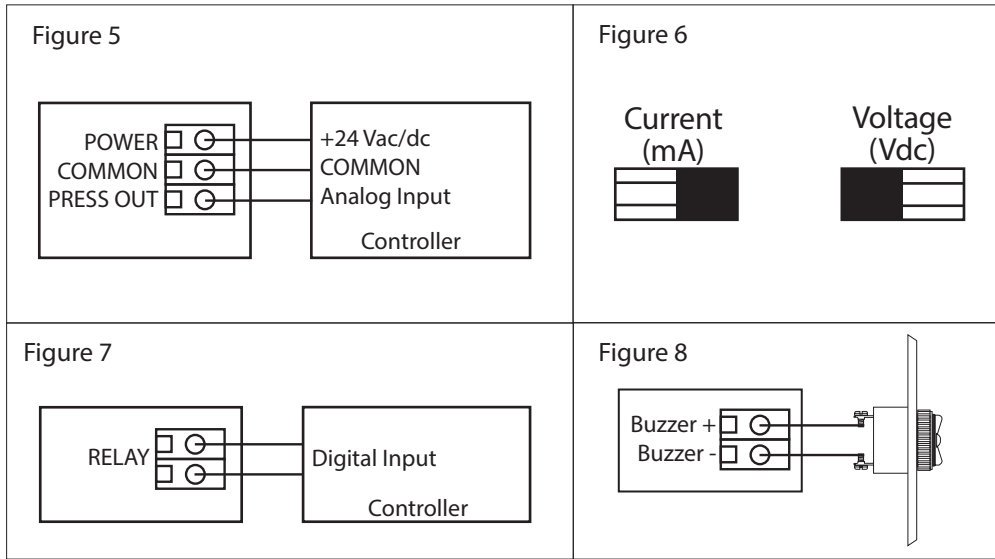
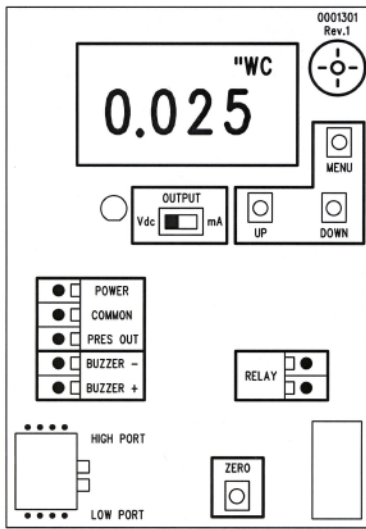

In voltage mode the output can be set to 0-5 or 0-10 Vdc via the menu. The current output operates in the Active mode and does not require a loop power supply. This means **the signal current is generated by the transmitter and must not be connected to a powered input or device damage will result.** Check the controller analog input to determine the proper connection before applying the power. Both current and voltage signals are referenced to the COMMON terminal. The voltage output signal has a minimum load that it is able to drive, similarly the current signal has a maximum load. Follow the ratings in the specification section or inaccurate readings may result.

The RELAY output is a normally open dry contact. The signal can be used to directly control an alarm, ventilation fan or may be connected to a digital input of the BAS for status monitoring. Ensure any load connected to relay is within the relay rating in the specification section.

The remote buzzer is an optional component that can be installed to give a remote indication of an alarm condition. The BUZZER output requires 2 wires (+ and -) to operate the 24 Vdc remote buzzer. Follow the polarity indications on both units when making the connections.

PNEUMATIC CONNECTIONS

The two pressure ports are labeled High Port and Low Port on the PCB. The output signal reads a positive value when the port pressure is higher on the High port than the Low port, so ensure these ports are connected correctly. One port will be left open to measure the room pressure where the device is installed and the other port is connected to a remote pickup outside the room to measure the differential pressure.

Use 1/16" ID flexible silicone tubing for the pressure connections. Tube size adapters are included to allow the use of 1/8" ID tubing. Arrange the tubing to minimize stress on the connections and ensure there are no kinks in the tubing. The tubing should be routed through the PCB access hole and out the back of the enclosure base.

Ensure the tubing to be used is clean and do not allow material to fall into the pressure ports, as contamination could damage the sensor. When removing tubing use care to avoid breaking the ports. In some cases it is better to cut the tubing off rather than pull it off, be careful not to cut the fitting or an air leak may occur.

POWER UP INSTRUCTION

Before turning on the power, verify all wiring to ensure that it complies with the wiring instructions described above and verify that the output signal type is correctly selected on the PCB. Also, review the specifications to ensure the power supply is correct and that the pressure is within the correct range. The product should be allowed to warm-up for several minutes before attempting to verify accuracy.

Operation can be verified by measuring the output signal. For voltage output configuration, measure the voltage between the PRES OUT and COMMON terminals. The voltmeter should read between 0-5 or 0-10 Vdc depending on the output range selected. For current output configuration, insert a mA meter in series with the PRES OUT terminal and it should read between 4 and 20 mA.

Upon applying power to the device the alarm condition is set to off so the relay, buzzer, LED and remote alarm are off. The analog output is set to the midpoint and the LCD will display the software version number such as 1.00 for 5 seconds. All keys are disabled during start-up mode. At the end of the start-up mode the device will enter normal operation.

NORMAL OPERATION

For a bipolar range such as ± 1 "wc, the pressure applied to the High port should be higher than pressure applied to the Low port for a positive output response. In this case, differential pressure can be measured using both ports. If the High port has a positive pressure with respect to the Low port, then the output indicates a positive pressure. Negative pressure is indicated if the High pressure is less than the Low pressure. The output pressure can be calculated as follows:

4-20 mA	Pressure = [(Output current - 4 mA) / 16 mA] x 2 x Range - Offset
0-5 Vdc	Pressure = (Output voltage / 5 V) x 2 x Range - Offset
0-10 Vdc	Pressure = (Output voltage / 10 V) x 2 Range - Offset

In the case of ± 1 "wc, 4 mA or 0 V = -1"wc and 20 mA or 5 V or 10 V = +1"wc. Since the transmitter is linear, 0"wc would be 12 mA or 2.5 V or 5 V.

During normal operation the device reads the pressure sensor and calculates the pressure value depending on the device model ranges and the selected pressure range. The pressure value is displayed on the LCD and sent to the analog output.

The output signal may be affected by the pressure averaging time setting in the menu. The pressure averaging setting controls how many readings are averaged to form the output value. The pressure averaging time defaults to 5 seconds and can be set from 1 to 60 seconds. The value effectively filters the output to prevent noise and false alarms.

The device also compares the output pressure value to the alarm set-points and takes appropriate action. If the pressure value exceeds either set-point then an alarm condition is set and the device will operate in alarm mode. Alarm mode activation is controlled by certain delay times and user settings described later. The device also monitors the keys and takes appropriate action if a key is pressed.

ALARM OPERATION

The alarm feature includes an on-board buzzer, silence switch, control relay, remote buzzer connection and LED.

The alarm feature has several settings that can be controlled by the setup menu. The device has two alarm trip points designated the high pressure alarm limit and the low pressure alarm limit. The high

pressure alarm defaults to 50% of the maximum pressure range and the low pressure alarm defaults to 50% of the minimum pressure range. For example, if the device is set to a ± 1 "wc, then the default low pressure alarm limit will be -0.5 "wc and the default high pressure alarm limit will be +0.5 "wc. This is the same result for Pa ranges.

The alarm set-points can be set over the pressure range with certain conditions. For this example the pressure range is ± 1 "wc.

- the low pressure alarm limit cannot go below the minimum pressure range setting (-1.0"wc)
- the high pressure alarm limit cannot go above the maximum pressure range setting (+1.0"wc)
- the high pressure alarm limit must always be greater than the low pressure alarm limit
- the minimum alarm span (high alarm - low alarm) must be at least 25 % of the pressure span (2"wc x 25 % = 0.5"wc)
- if the minimum span is reached while adjusting one of the alarm limits, then the other alarm limit will be "pushed".

In this example for the ± 1 "wc range, these are some possible alarm settings: -1.0 to 0.5"wc, -0.75 to -0/25"wc, -0/5 to 0"wc, -0.25 to 0.25"wc, 0 to 0.5"wc, 0.5 to 1.0"wc.

The alarm also has settings for on delay and off delay which can be set via the menu. Both of these default to 5 seconds but may be changed from 1 to 59 seconds or 1 to 10 minutes. For an alarm condition to be set the pressure value must exceed either alarm trip point for more than the alarm on delay time. For an alarm condition to be reset the pressure value must return to a non-alarm value for more than the alarm off delay time.

When an alarm condition is set the red LED will flash, the relay output will activate, the local buzzer will sound and the remote buzzer output will activate. If the alarm condition is reset, all four outputs will deactivate. The LED flashes at a rate of 1 second on / 1 second off, the relay and remote buzzer are held on and the local buzzer sounds at a rate of 1 second on / 5 seconds off.

The alarm can be silenced by pressing the front cover silence switch during an alarm condition. In this case the buzzers and relay will de-activate but the LED continues to flash until the alarm condition is removed. The alarm silence time can be set in the menu to 1-60 minutes or forever and the default is 30 minutes. This means that if the silence switch is pressed and the alarms are silenced (and the alarm condition is not reset) then the alarm will re-activate after the silence time has expired. For the default setting of 30 minutes, the alarm buzzers and relay will activate again after 30 minutes of silence if the alarm condition still exists. If the delay is set to forever, then the alarms will not activate again in silence mode until the alarm condition is cleared and another alarm condition is set.

The alarm can be disabled by the user by holding the front cover silence switch for 5 seconds. It can be re-enabled by holding the switch again for 5 seconds. When the alarm is disabled, the OFF icon will be lit on the LCD and no alarms will be activated.

The local alarm buzzer volume can be set or muted via the menu and an alarm test can be initiated via the menu. The alarm test will force an alarm condition to be set. Since the menu has a 5 minute time-out, if the alarm is left on it will reset after 5 minutes back to a normal condition.

AUTO ZERO OPERATION

A sensor auto zero can be initiated by pressing and holding the internal ZERO switch for at least 3 seconds. If both pressure ports are close to zero pressure (open to ambient), then the device will calibrate with a new zero point.

SETUP MENU OPERATION

The setup menu can be accessed by pressing the internal <MENU> key at any time after the start-up mode.

The system suspends operation when in the menu and holds the last pressure value on the output. If an alarm condition was present then it will be reset to enter the menu and alarm operation is disabled while in the menu (except for alarm test). If the setup menu is not active for 5 minutes (no key press), then the menu will exit and the device returns to normal operation.

<MENU>

Press and release to enter the Setup Menu.

1. OUTPUT



This item sets the analog output voltage span to either 0-5 (default) or 0-10 Vdc. Use <UP> and <DOWN> to toggle 0-5 or 0-10.

<MENU>

Press to advance to next menu item

2. PRESSURE SCALE



The pressure scale defaults to "wc. Use <UP> or <DOWN> to toggle it to Pa.

<MENU>

Press to advance to next menu item

3. PRESSURE RANGE



The pressure range defaults to HI. Pressure ranges per model are shown below:
RP01 = HI (± 1 "wc or ± 250 Pa), LO (± 0.5 "wc or ± 125 Pa)
RP02 = HI (± 0.25 "wc or ± 60 Pa), LO (± 0.125 "wc or ± 30 Pa)
This can be changed to LO using <UP> or <DOWN>.

<MENU>

Press to advance to next menu item

4. PRESSURE AVERAGING



The pressure averaging time defaults to 5 seconds. This can be changed from 1-60 seconds using <UP> or <DOWN>.

<MENU>

Press to advance to next menu item

5. HIGH PRESSURE ALARM



The high pressure alarm limit defaults to (+ range max x 50%). This equals + 0.5 "wc for the ± 1 "wc range, + 125 for the ± 250 Pa range, etc. It can be changed using <UP> or <DOWN> throughout the range. Resolution for each range is: ± 1 "wc (0.05), ± 0.5 "wc (0.02), ± 0.25 "wc (0.01), ± 0.125 "wc (0.01), ± 250 Pa (10), ± 125 Pa (5), ± 60 Pa (2) and ± 30 Pa (1). Note that the ± 250 Pa range must be displayed as /10 such that it is - 25H to 25H.

<MENU>

Press to advance to next menu item

6. LOW PRESSURE ALARM



The low pressure alarm limit defaults to (- range max x 50%). This equals - 0.5 for the ± 1 "wc range, - 125 for the ± 250 Pa range, etc. It can be changed using <UP> or <DOWN> throughout the range. Note the restrictions as described in Alarm Operation section.

<MENU>

Press to advance to next menu item

7. ALARM ON DELAY



The alarm on delay defaults to 5" (seconds). It can be changed from 1-59" (seconds) and 1-10' (minutes) using <UP> or <DOWN>.

<MENU>

Press to advance to next menu item

8. ALARM OFF DELAY



The alarm off delay defaults to 5" (seconds). It can be changed from 1-59" (seconds) and 1-10' (minutes) using <UP> or <DOWN>.

<MENU>

Press to advance to next menu item

9. ALARM SILENCE TIME



The alarm silence time defaults to 30' (minutes). It can be changed from 1-60' (minutes) or F for forever using <UP> or <DOWN>.

<MENU> Press to advance to next menu item

10. BUZZER VOLUME



The buzzer volume defaults to 2 (high volume). It can be changed to 0 (off) or 1 (low volume) using <UP> or <DOWN>.

<MENU> Press to advance to next menu item

11. BACKLIGHT



The LCD backlight defaults to 1 (on). It can be toggled to 0 (off) using <UP> or <DOWN>.

<MENU> Press to advance to next menu item

12. ALARM TEST



The alarm defaults to OFF. It can be set to On using <UP> or <DOWN>.

<MENU> Press to advance to next menu item

SPECIFICATIONS

GENERAL

Sensor Accuracy.....	±1% FS of selected range (±2% for 0.125"wc and 30 Pa ranges)
Stability	±1% FS max (1 year)
Thermal Effect.....	<±3.5% FS max, 5 to 50°C (41 to 122°F)
Response Time	1 to 60 seconds (menu selectable)
Proof Pressure	100"wc (24.9 kPa)
Burst Pressure	200"wc (49.8 kPa)
Operating Conditions	0 to 60°C (32 to 140°F), 0 to 90 %RH non-condensing
Storage Temperature	-40 to 70°C (-40 to 158°F)
Media Compatibility.....	Dry air or inert gas
Zero Adjust	Push-button auto-zero
LCD Display.....	3½ digit LCD, 0.45" digit height, unit symbols and backlight
Wiring Connections.....	Screw terminal block (14 to 22 AWG)
Pressure Connections	Ports for 1/16" ID tubing (1/8" ID adapters included)
Enclosure	White ABS, IP30 (NEMA 1) 84mm W x 119mm x 29mm H (3.3" x 4.7" x 1.15")
Weight	115g (4oz)
Country of Origin.....	Canada

POWER SUPPLY

Power Supply.....	24 Vac/dc ±10%
Power Consumption	70 mA max with alarms on
Output Signal	4-20 mA (3 wire), 0-5 or 0-10 Vdc (3 wire), field selectable
Output Drive.....	Current: 750 Ω max Voltage: 2 KΩ min

ALARM

Relay	N.O. contact, 2 Amps @ 120 Vac or 30 Vdc
Trip Point	Upper and Lower alarms adjustable over the pressure range
Delay.....	0 to 10 minutes (menu selectable)

PRESSURE RANGES

RPC01.....	±1"wc, ±0.5"wc, ±250 Pa, ±125 Pa
RPC02.....	±0.25"wc, ±0.125"wc, ±60 Pa, ±30 Pa

DIMENSIONS

