

INTRODUCTION

The Particulate Matter Transmitter uses an optical sensor based on laser scattering principles and features innovative contamination-resistance technology to perform highly accurate and reliable PM measurements. With a continuous-operation lifetime of more than 8 years, the sensor will provide long-term reliability and high resolution particle size binning for the detection of environmental dust and other particles.

The sensor is housed within an attractive, low-profile enclosure to monitor ambient PM levels for room applications. The sensor achieves excellent performance characteristics, including high accuracy and low power consumption to ensure stable long term operation. The

PMRMC features both 4-20 mA and voltage outputs (0-5 / 0-10 Vdc) for simple integration into any building automation system to assure good indoor air quality. The device is also available with an RS-485 MS/TP network connection including either Modbus or BACnet® protocol.

BEFORE INSTALLATION

Read these installation instructions carefully before commissioning the PM Sensor. Failure to follow these instructions may result in product damage. Do not use in an explosive or hazardous environment, with combustible or flammable gases, as safety or emergency stop devices or in any other application where failure of the product could result in personal injury. **Use electrostatic discharge precautions during installation and do not exceed the device ratings.**

MOUNTING

The particulate matter transmitter mounts directly on a wall or onto an electrical wall box and should be mounted to a wall box five feet from the floor. Do not mount the sensor near doors, opening windows, supply air diffusers, or other known air disturbances. Avoid areas where the sensor is exposed to vibrations or rapid temperature changes.

The cover is hooked to the base at the top edge and must be removed from the bottom edge first. Use a small Phillips screwdriver to loosen the security screw as shown in Figure 1. (Complete removal of the screw is not required). Use a screw driver to carefully pry each bottom corner if necessary tip the cover away from the base as shown in Figure 2 and sit it aside.

The PCB must be removed from the base to access the mounting holes. Follow usual anti-static procedures when handling the PCB. The PCB is removed by pressing the enclosure base to unsnap the latch near the bottom edge, then the PCB can be lifted out of the base as shown in Figure 3.

Set the PCB aside until the base is mounted on the wall. For added protection, place the PCB in the supplied anti-static bag.

Mount the base by screwing to an electrical box or directly to the wall as shown in Figure 4. The mounting hole locations are shown in the Dimension drawings. After the base is mounted

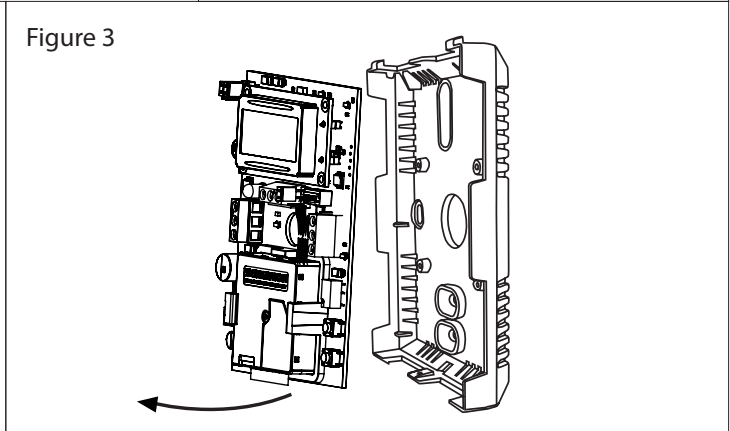
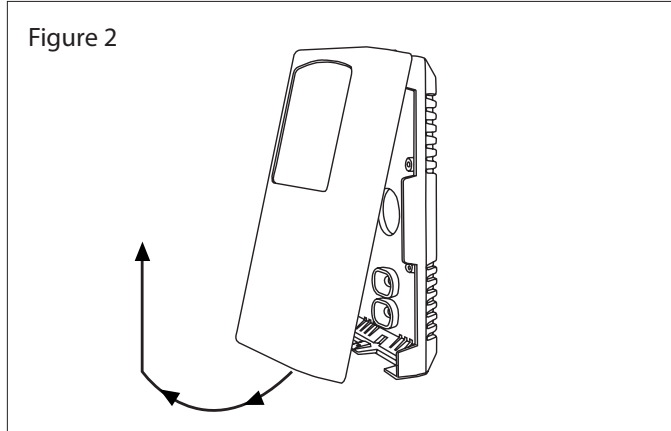
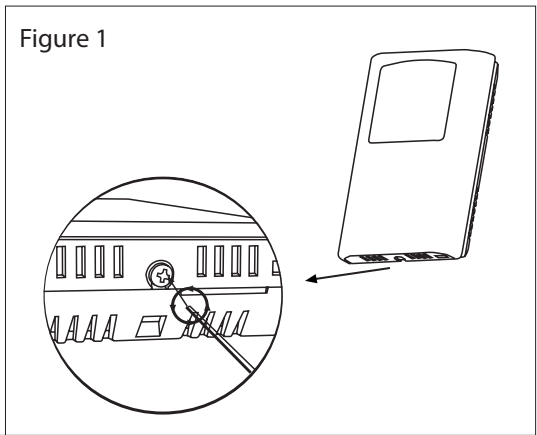
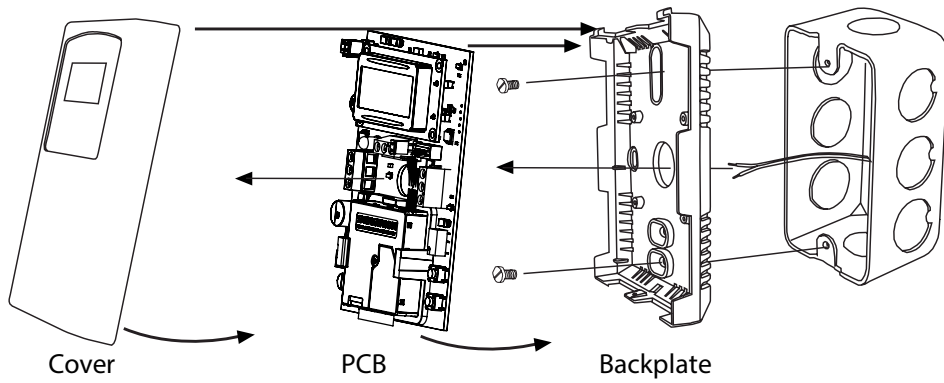

Figure 4



using the appropriate holes, remove the PCB from the anti-static bag and feed the wires through the center hole of the PCB. Place the top of the PCB into the latches on the top of the backplate and gently snap the bottom edge of the PCB into place as shown in Figure 4.

Make wire connections as per the Wiring Illustrations on Page 2 and install decorative cover by placing the top of the cover into the cover holder on the top of the backplate and snapping the bottom into place as shown in Figure 4. Tighten security screw with a screwdriver.

WIRING

The particulate matter sensor has standard screw block connectors and easy wire access to facilitate wiring. It is recommended that shielded twisted pair wiring at least 22 AWG be used for all connections and that the device wires not be run in the same conduit with wiring used to supply inductive loads such as motors. Disconnect the power supply before making any connections to prevent electrical shock or equipment damage. Make all connections in accordance with national and local electrical codes.

The device power (24 Vac/dc) is connected to the terminal marked PWR (POWER). This terminal is used for the positive dc voltage or the hot side of the ac voltage. The device is reverse voltage protected and as such will not operate if connected backwards.

The common of the power supply is connected to the terminal marked COM (COMMON). Note that this device has a half-wave type power supply which means the power supply common is the same as the output signal common. Therefore, several devices may be connected to one power supply and the output signals all share the same signal common. Use caution when grounding the secondary of an ac transformer or when wiring multiple devices to ensure that the circuit ground point is the same on all devices and the controller. In general, the transformer should not be connected to earth ground when using devices with an RS-485 network connection.

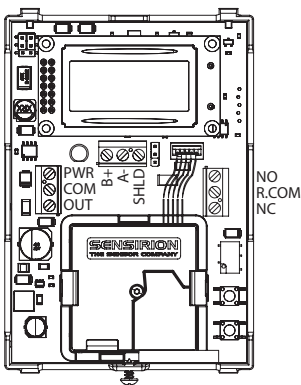

The analog output signal is available on the OUT (OUTPUT) terminal. This signal is jumper selectable for either voltage or 4-20 mA output signal type. See Figure 5. The voltage output signal defaults to 0-5 Vdc but may be changed to 0-10 Vdc via the menu. These options are clearly indicated on the device PCB. The analog output signal is typically connected directly to the Building Automation System (B.A.S.) and used as a control parameter or for logging purposes. Check the controller Analog Input type to determine the correct connection and signal type before applying power. The device generates the analog output signal (sourcing) and must not be connected to a powered input or device damage may occur.

Figure 5

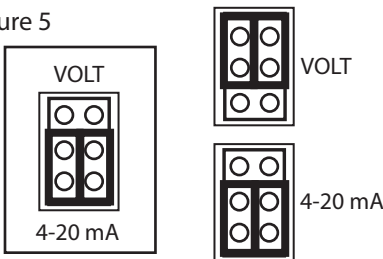

For voltage type output signal the device has a minimum load that it is able to drive, similarly for current type output signal the device has a maximum load that it is able to drive with a particular power supply voltage. Observe and follow these ratings in the Specification section or inaccurate reading may result. The 4-20 mA output signal can easily be converted to a 1-5 Vdc signal for controllers accepting this type of input. Simply insert a 250 ohm (0.1% is best) resistor between the "+" and "-" inputs of the controller. This will convert the 4-20 mA signal to the desired 1-5 Vdc. See Figure 6.

Figure 6

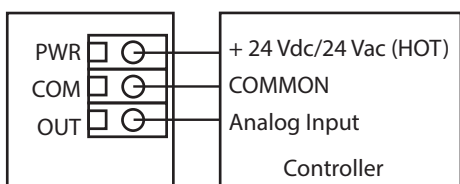
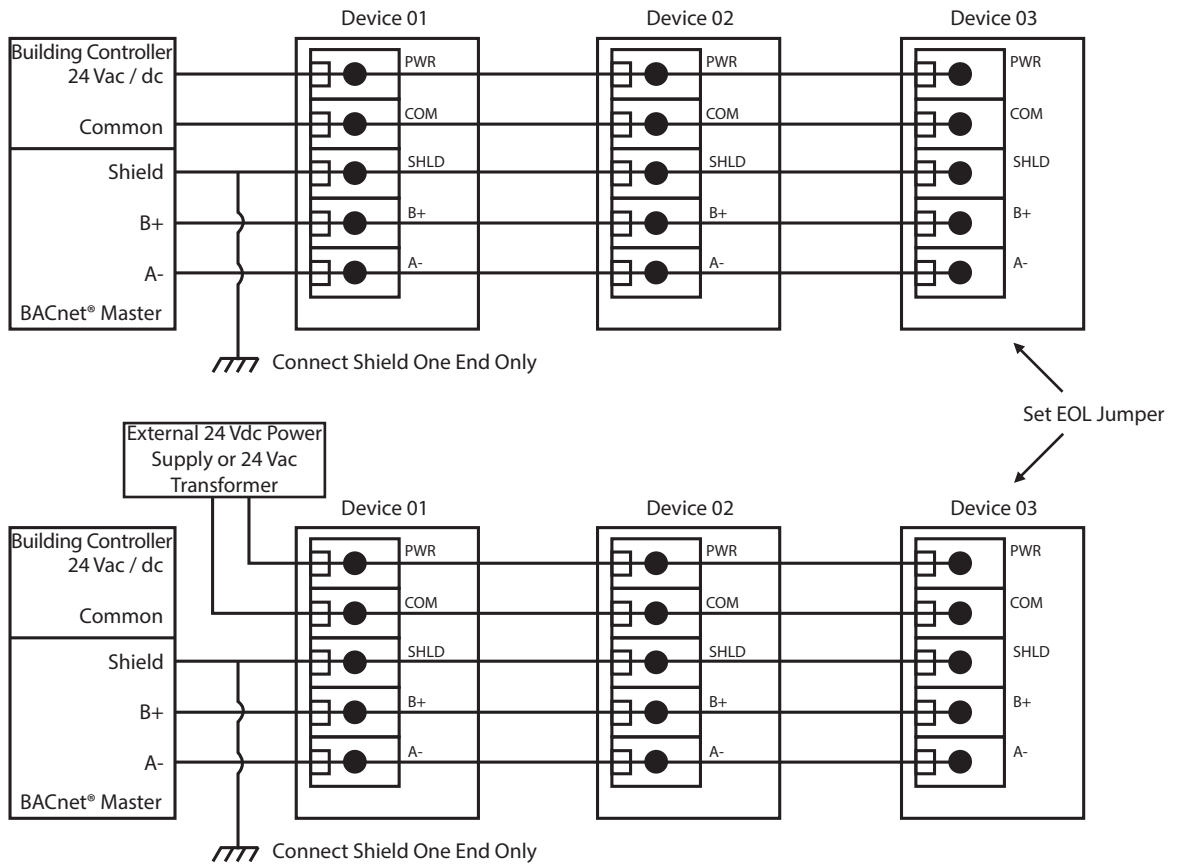
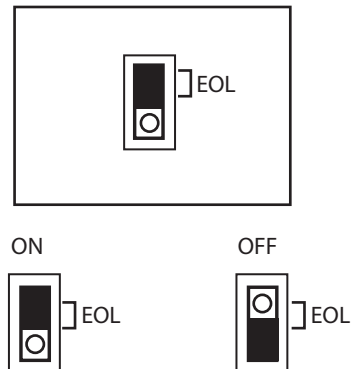

Figure 7



If the device includes the optional network connection, use twisted shielded pair to connect to the terminals marked A-, B+ and SHLD (SHIELD). The positive wire connects to B+, the negative to A- and the cable shield must be connected to the SHLD terminal on each device. The shield wire should be connected to earth ground at one end of the network only. See Figure 7. If the device is installed at either end of an RS-485 network, an end-of-line (EOL) termination resistor (121 ohms) should be installed in parallel with the A- and B+ terminals. This device includes a network termination resistor and jumper that can be used to connect the EOL resistor on the PCB. Simply move the jumper to the EOL position and no external resistor is required. See Figure 8.

Figure 8



A network segment is a single shielded wire loop run between several devices (nodes) in a daisy chain configuration. The total segment length should be less than 1220 meters (4000 feet) and the maximum number of nodes on one segment length is 64. Nodes are any device connected to the loop and include controllers but do not include the EOL terminators. To install more than 64 devices, or to increase network length, repeaters will be required for proper communication. The maximum daisy chain length (segment) depends on transmission speed (baud rate), wire size and number of nodes. If communication is slow or unreliable, it may be necessary to wire two daisy chains to the controller with a repeater for each segment.

Figure 9

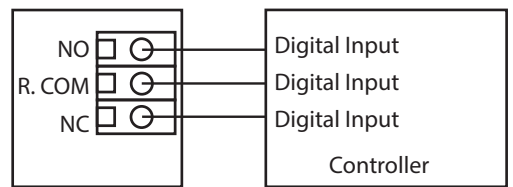

An optional signal is the alarm relay output available on the NO (NORMALLY OPEN), NC (NORMALLY CLOSED) and R.COM (RELAY COMMON) terminals. The R.COM terminal is not connected to the power supply COM terminal, the relay output is completely isolated. The relay contacts may be connected to a controller Digital Input (DI) for status monitoring or used to directly control an alarm or ventilation fan. Do not exceed the device contact ratings. In some cases a separate control relay may be used between the particulate matter sensor relay and a large fan for example. See Figure 9.

OPERATION - START-UP

After applying power to the device, it will enter the start-up mode and the LCD will indicate the software version number, the PM range, the PM alarm setpoint (if applicable) and the analog output type for two seconds each.

Version
1.00

PM Range
PM1.0

PM Alarm
150ug/m3

Output
4-20 mA

If the network option is installed, then the start-up sequence will also show the network protocol, the baud rate and the device address. Then the device will start normal operation and display the PM concentration value.

Network
Modbus

BaudRate
9600

Address
3

100
ug/m3

OPERATION - NORMAL

During normal mode the device reads the PM sensor and calculates the Air Quality Index based on a 24 hour time average. The real time PM concentration value is displayed on the LCD and set as the output value for the analog output. The output value is updated once per second. The LCD may be configured via the menu to display either the PM value or the AQI. If the optional tri-color LED is installed, it will change color to indicate Good (Green), Moderate (Yellow) or Poor (Red) air quality.

On start-up when the first readings are obtained, the Air Quality reading for the device averages the concentration level as necessary until the required time base setting is reached. For example, if only 10 readings are available then the output value is calculated as the average of those 10 readings. The next output value will be an average of 11 readings. This short-averaging will continue until the unit has been running for 24 hours. Once 24 hours is reached then the AQI value will always be the average of readings over the past 24 hours.

The device also monitors the keypad and takes appropriate menu actions for setup. The network version of the product allows for configuration of settings via BACnet® or Modbus protocol and the BACnet® objects or Modbus registers are updated with the appropriate values and alarm conditions are monitored.

OPERATION - ALARM

All models except for the analog output only without relay will have a PM setpoint alarm. The alarm will control the optional relay or network variables as applicable to the model. The PM alarm setpoint, hysteresis and time delay may be configured via the menu or network. The details of each setting and operation is explained in the Setup Menu section.

OPERATION - SETUP MENU

The Setup Menu has several items as shown below. To enter the menu, press and release the <MENU> key while in normal operation. This will enter the Setup Menu step 1, pressing the <MENU> key a second time advances to step 2. Each press of the <MENU> key saves the selection and advances the menu item. The <ROLL> key is used to make changes to program variables by scrolling through the available options. If the Setup Menu is not active for 5 minutes (no key press), then the menu will exit and the device returns to normal operation.

<MENU> Press and hold to enter the setup menu. Once in menu release <MENU>.

1. PARTICULATE MATTER RANGE

PM Range
PM10

The default PM Range is PM10. Use <ROLL> to change the range as required to either PM1.0, PM2.5, PM4.0, or PM10.

<MENU> Press to advance to next menu item

2. VOLTAGE OUTPUT SIGNAL

Output
0-5 Vdc

Use <ROLL> to set the voltage output signal type to 0-5 or 0-10 Vdc. The factory default is 0-5 Vdc.

<MENU> Press to advance to next menu item

3. ANALOG OUTPUT

Output
Direct

The analog output defaults to Direct (4-20 mA, 0-5 Vdc or 0-10 Vdc). Use <ROLL> to change it to Reverse (20-4 mA, 5-0 Vdc or 10-0 Vdc) if required.

<MENU> Press to advance to next menu item

4. ANALOG OUTPUT SCALE

Scale
1000 ug

The default analog output scale is 0-1000 ug/m³. The maximum value can be changed from 500 to 1000 (resolution 100) using <ROLL> if required. For example, the output can be 4-20 mA = 0-700 ug/m³.

<MENU> Press to advance to next menu item

5. DISPLAY INFORMATION

Display
ug/m³

Use <ROLL> to configure the display information as Mass Concentration in ug/m³ or as an Air Quality Index (0-500 AQI / GOOD, MODERATE, POOR). The display will change from ug/m³ to AQI.

<MENU> Press to advance to next menu item

6. BACKLIGHT

Backlite
Auto

The backlight operation defaults to Auto operation. It can be set to Off or On using <ROLL>. Auto means the LCD backlight only lights when a menu is accessed, off means it never lights and on means it is always on.

<MENU> Press to advance to next menu item

Only if **Relay OR Network Option** installed

7. SETPOINT ALARM

PM Alarm
150 ug

Setpoint for PM alarm and relay (if installed) activation. Default setpoint for alarm activation is 150 ug/m³. Use <ROLL> to adjust from 50-900 ug/m³. Resolution is 10 ug/m³.

<MENU> Press to advance to next menu item

8. ALARM HYSTERESIS

Alrm Hys
20 ug

The default PM alarm hysteresis is 20 ug/m³. Use <ROLL> to change to 10, 15, 20, 25, 30, 35 or 40 ug/m³. If the PM Alarm setpoint = 150 and hysteresis = 20, then the alarm will be set if the PM exceeds 150 and will reset when it falls below 130.

<MENU> Press to advance to next menu item

9. ALARM DELAY

Alrm Dly
0 min

The default PM alarm delay is 0 minutes. Use <ROLL> to change from 0 to 10 minutes to prevent false alarms. Resolution is 1 minute.

<MENU> Press to advance to next menu item

10. PM ALARM

PM Alarm
Test Off

The default PM alarm test is Off. Use <ROLL> to toggle it Off or On. When set to On, an alarm condition is forced for testing purposes. If a relay is installed it will also be activated. The alarm condition will be reset to Off.

<MENU> Press to advance to next menu item

11. BAUD RATE

BaudRate
9600

The default network baud rate is 9600. Use <ROLL> to select 9600, 19200, 38400, 57600, 76800 or 115200 as required.

<MENU>

Press to advance to next menu item

12. ADDRESS

Address
3

The default network address is 3 for BACnet® and 1 for Modbus. Use <ROLL> to select 0-127 for a BACnet® device or 1-255 for a Modbus device.

<MENU>

Press to advance to next menu item

13. PARITY VALUE

ModBus
Parity N

Use <ROLL> to select a parity value of N (none), O (odd) or E (even). The factory default Modbus parity bit is N (none).

<MENU>

Press to advance to next menu item

14. STOP BITS

ModBus
Stop 1

Use <ROLL> to toggle the stop bits between 1 and 2. The default Modbus stop bits is 1.

<MENU>

Press to advance to next menu item

15. CRC VALUE

ModBus
CRC A001

Use <ROLL> to set the CRC value to A001 (CRC-16 reverse), 1021 (CITT), 8005 (CRC-16) or 8408 (CITT reverse). The default CRC polynomial is 0xA001.

<MENU>

Press to advance to next menu item

16. SLAVE RESPONSE

ModBus
CRC A001

Use <ROLL> to change the value from MIN (minimum) to 50, 100, 150, 200, 250, 300 or 350ms. The factory default slave response delay is minimum (minimum delay means just more than 3.5 character time delays, 4ms for 9600 baud rate, for example).

<MENU>

Exits the Setup Menu and returns to normal mode.

OPERATION - TESTING/COMMISSIONING (OPTIONAL)

To perform testing or commissioning the unit should be configured to display PM reading since AQI reading requires operation over 24-hour period. To verify sensor is reading properly a Greystone CO BUMP KIT or equivalent can be used to generate particulates.

To prepare for testing open CO BUMP KIT, follow instructions included with kit to generate smoke from wick. The CO Adapter is not required for testing the PM sensor.

Hold wick close to inlet of sensor (bottom of cover).

Sensor PM reading should increase.

This will verify sensor is reading higher PM levels and is operational. If sensor readings do not increase with smoke then sensor is faulty.

DIMENSIONS

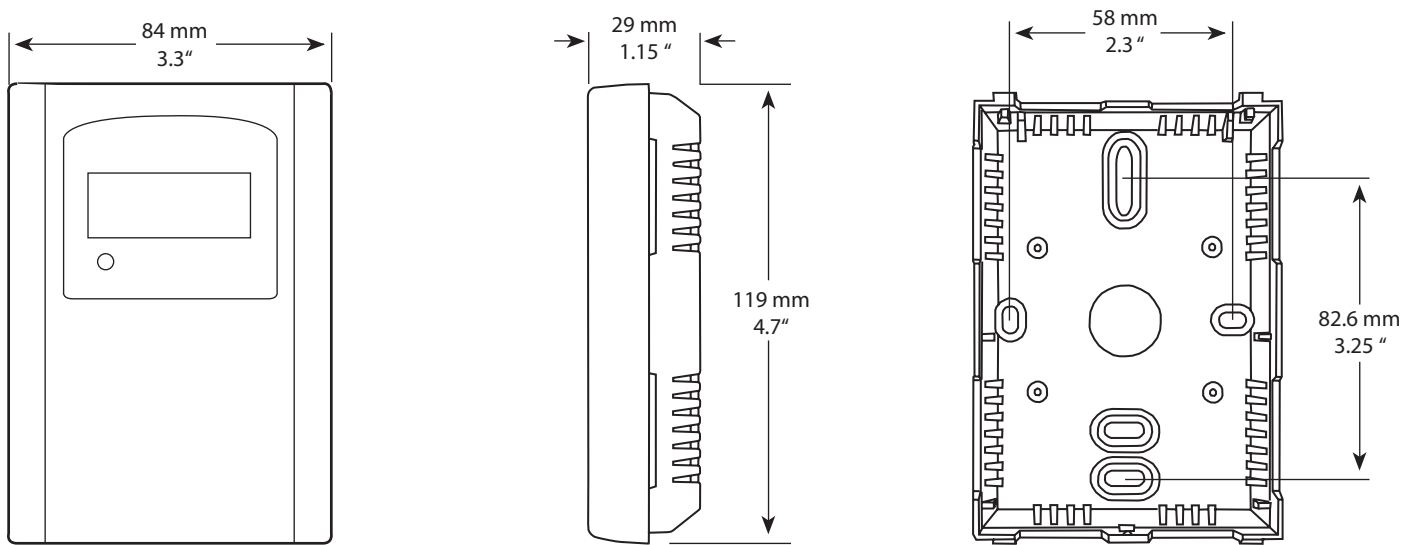

SPECIFICATIONS

PM Sensor

Sensor	Laser scatter method
Particle Size.....	PM1.0, PM2.5, PM4.0, or PM10 (selectable)
Mass Concentration.....	0 to 1000 ug/m ³
Resolution	1 ug/m ³
Accuracy	±10 ug/m ³ (0 to 100 ug/m ³), ±10% (100 to 1000 ug/m ³)
Response Time	1 second
Sensor Lifetime	>8 years

Analog Model

Consumption.....	75 mA max @ 24 Vdc, 100 mA max @ 24 Vac
Output Signals.....	4-20 mA (sourcing) or 0-5 Vdc / 0-10 Vdc (selectable)
Output Drive Capability	Current: 550Ω max Voltage: 5,000Ω min
Output Scale	0 to 1000 ug/m ³ (menu selectable)

BACnet® Model

Consumption	50 mA max @ 24 Vdc, 80 mA max @ 24 Vac
Interface.....	MS/TP, 2-wire RS-485
Baud Rate	9600, 19200, 38400, 57600, 76800 or 115200 (menu selectable)
Address Range.....	0 to 127 (menu selectable)

Modbus Model

Consumption	50 mA max @ 24 Vdc, 80 mA max @ 24 Vac
Interface.....	MS/TP, 2-wire RS-485, RTC
Baud Rate	9600, 19200, 38400, 57600, 76800 or 115200 (menu selectable)
Address Range.....	1 to 255 (menu selectable)

Tri-Color LED (optional)

Good	Green (0 to 50 ug/m ³)
Moderate	Yellow (51 to 150 ug/m ³)
Poor	Red (151 to 1000 ug/m ³)

PM Alarm Relay (optional)

Contact Ratings.....	Form C (N.O. + N.C.), 2A @ 140 Vac, 2A @ 30 Vdc
Relay Setpoint + Hysteresis ...	Programmable via menu
Relay Time Delay.....	Programmable via menu

General

LCD Size	35mm W x 15mm H (1.4" x 0.6") alpha-numeric 2 line x 8 characters
LCD Backlight.....	Enable or disable via menu
Display Values	0 to 500 Air Quality Index or 0 to 1000 ug/m ³
Power Supply	24 Vac/dc ±20% (non-isolated half-wave rectified)
Protection Circuitry.....	Reverse voltage protected, over-voltage protected
Operating Conditions	0 to 50°C (32 to 122°F), 20 to 80 %RH non-condensing
Storage Conditions	-30 to 60°C (-22 to 140°F)
Wiring Connections.....	Screw terminal block (14 to 22 AWG)
Enclosure Dimensions	84mm W x 117mm H x 29mm D (3.3" x 4.6" x 1.15")
Enclosure Material.....	White ABS, IP30 (NEMA 1)
Weight.....	5.3 oz (150 gm)
Country of Origin.....	Canada

Accessories

PMFRSM	Replaceable sensor module and wire harness
--------------	--

NETWORK SETUP GUIDE

The network setup guide describes the implementation of the BACnet® or Modbus protocol. It is intended to assist control system programmers who may need to add support to their systems to communicate with the device.

BACnet® and Modbus setup guide downloads are available online.



BACnet® PROTOCOL

<https://downloads.greystoneenergy.com/SG/SG-PMXXXBAC.pdf>



MODBUS PROTOCOL

<https://downloads.greystoneenergy.com/SG/SG-PMXXXMOD.pdf>