

INTRODUCTION

The network temperature sensor is designed for use in environmental monitoring and control systems where high performance and stability are demanded. It's state-of-the-art design combines digital linearization and temperature compensation with a highly accurate and reliable thermoset polymer based capacitance humidity sensor and curve-matched NTC thermistor temperature sensor for reliability and accuracy in the most critical applications.

BEFORE INSTALLATION

Read these instructions carefully before installing and commissioning the device. Failure to follow these instructions may result in product damage. Do not use in an explosive or hazardous environment, with combustible or flammable gases, as a safety or emergency stop device or in any other application where failure of the product could result in personal

injury. Take electrostatic discharge precautions during installation and do not exceed the device ratings.

MOUNTING

The room type sensor installs directly on a standard electrical box and should be mounted five feet from the floor of the area to be controlled. Do not mount the sensor near doors, opening windows, supply air diffusers or other known air disturbances. Avoid areas where the detector is exposed to vibrations or rapid temperature changes.

The cover is hooked to the base at the top edge and must be removed from the bottom edge first. Use a small Phillips screwdriver to loosen the security screw as shown in Figure 1. (Complete removal is not required). Use a screw driver to carefully pry each bottom corner if necessary. Tip the cover away from the base and sit it aside as shown in Figure 2.

Figure 1

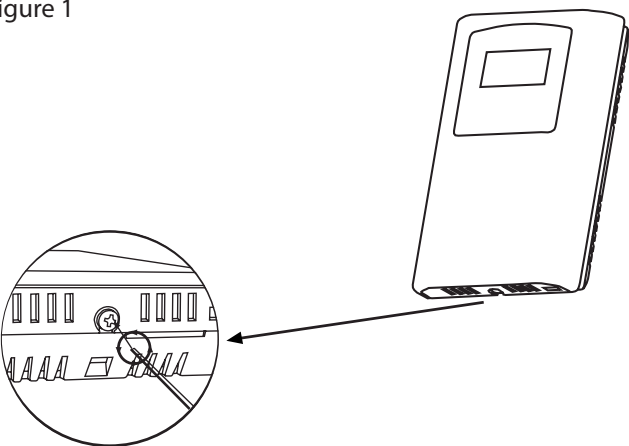
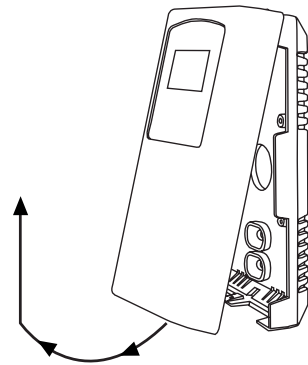

Figure 2



The PCB must be removed from the base to access the mounting holes. Follow usual anti-static procedures when handling the PCB and be careful not to touch the sensors. The PCB is removed by pressing the enclosure base to unsnap the latch near the bottom edge, then the PCB can be lifted out of the base as shown in Figure 3.

Sit the PCB aside until the base is mounted on the wall. For added protection, place the PCB in the supplied anti-static bag.

Mount the base by screwing it to an electrical box or directly to the wall as shown in Figure 4. The mounting hole locations are shown on page 4.

After the base is screwed to an electrical box or the wall using the appropriate holes, remove the PCB from the anti-static bag, feed connection wires through center hole and place the top of the PCB into the PCB holders on the backplate and snap the bottom of the PCB into place as shown in Figure 4.

Make wire connections as per the Wiring Illustrations and install decorative cover by placing the top of the cover into the cover holder on the top of the backplate and snapping the bottom into place as shown in Figure 4. Tighten security screw with a screwdriver.

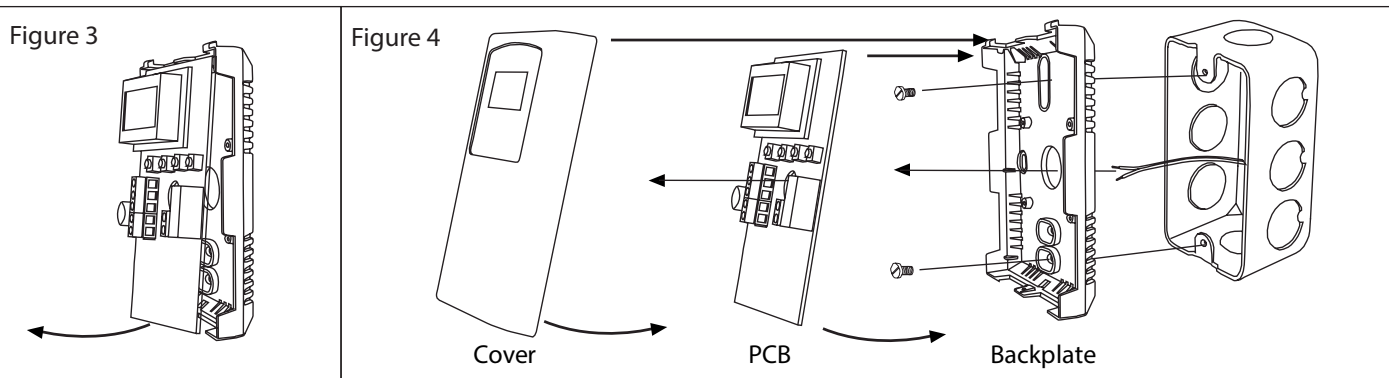

WIRING

- Deactivate the 24 Vac/dc power supply until all connections are made to the device to prevent electrical shock or equipment damage. Follow proper electrostatic discharge (ESD) handling procedures when installing the device or equipment damage may occur.
- Use 22 AWG shielded wiring for all connections and do not locate the device wires in the same conduit with wiring used to supply inductive loads such as motors. Make all connections in accordance with national and local codes.
- Connect the 24 Vac/dc power supply to the terminals labeled POWER and COMMON. Use caution if 24 Vac power is used and one side of the transformer is earth-grounded. See Figure 5.
- The transformer should NOT be connected to earth ground when using devices with RS-485 network connections. The device is reverse voltage protected and will not operate if connected backwards.
- Connect the RS-485 network with twisted shielded pair to the terminals marked A(-), B(+) and SHIELD.
- The positive wire connects to B(+) and the negative wire connects to A(-) and the cable shield must be connected to the SHIELD terminal on each device. See Figure 5.
- If the device is installed at either end of an RS-485 network, an end-of-line (EOL) termination resistor (121 ohm) should be installed in parallel to the A(-) and B(+) terminals.
- This device includes a network termination jumper and will connect the 121 ohm resistor correctly on the PCB. Simply move the jumper to the EOL position and no external resistor is required. See Figure 6.

The ground wire of the shielded pair should be connected to earth ground at the end of the network and the master is not grounded. Do not run bus wiring in the same conduit as line voltage wiring or other wiring that switches power to highly inductive loads such as contactors, coils or motors.

A network segment is a single shielded wire loop run between several devices (nodes) in a daisy chain configuration. The total segment length should be less than 4000 feet (1220 meters) and the maximum number of nodes on one segment is 127. Nodes are any device connected to the loop and include controllers, repeaters and sensors such as this one but do not include the EOL terminators. To install more than 127 devices, or to increase the network length, repeaters will be required for proper communication. The maximum daisy chain length (segment) depends on transmission speed (baud rate), wire size and number of nodes. If communication is slow or unreliable, it may be necessary to wire two daisy chains to the controller with a repeater for each segment.

An optional signal is the relay output available on the RELAY terminals. The relay output is completely isolated and has a Normally Open (NO) signal. This signal can be used to directly control an alarm or ventilation fan. See Figure 7.

The optional D INPUT (digital input) signal accepts a dry-contact only with respect to COMMON and registers in BACnet or Modbus. See Figure 8.

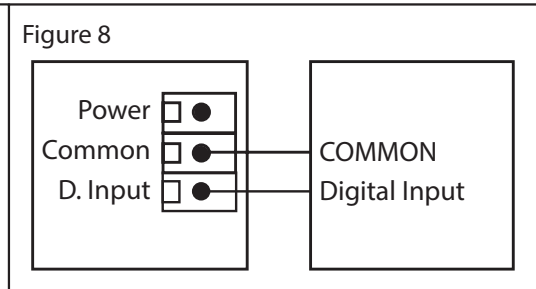
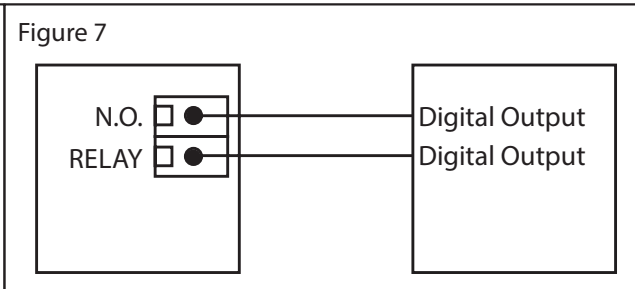
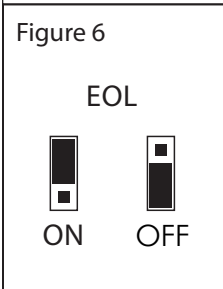
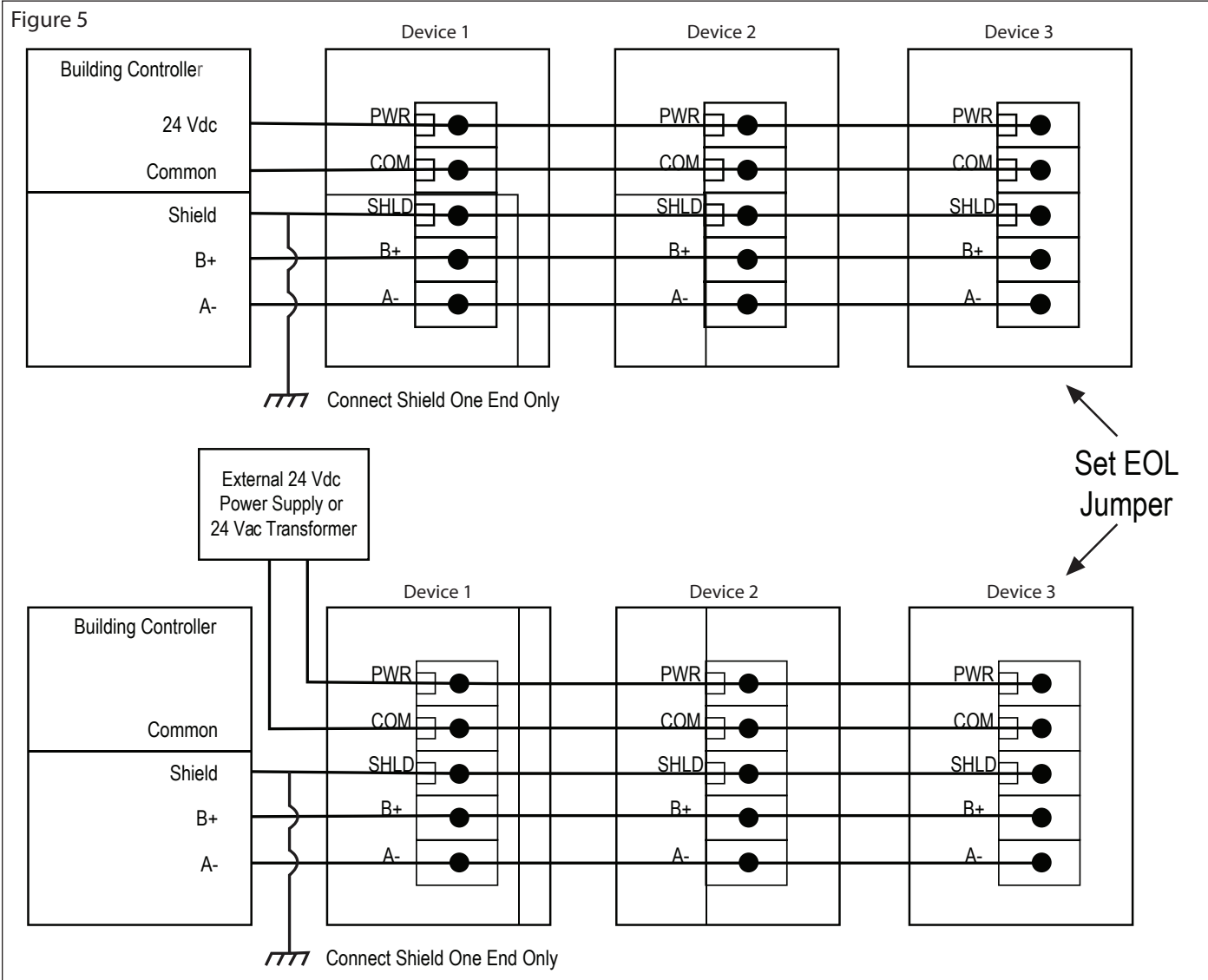
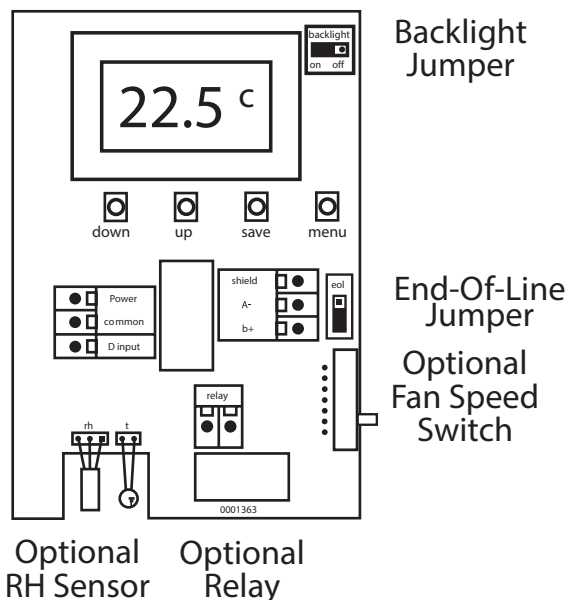

Figure 9



USER MENU

To enter the menu, press and release the <MENU> key while in normal operation. This will enter the Setup menu step 1, pressing the <MENU> key a second time advances to step 2. Each press of the <MENU> key advances the menu item. No values are saved or changed by using the <MENU> key. The <UP> and <DOWN> keys are used to make changes to program variables by scrolling through the available options. When a value is changed, use the <SAVE> key to save it to memory and advance to the next menu item. Actual menu displays with the default value are shown.

START-UP

Verify the transmitter is properly wired and connections are tight. Apply power and note that the LCD will indicate the software version number and then the device will begin reading the sensor values and display them on the LCD.

OPERATION

In normal operation the device reads the temperature and RH (if installed) sensors and updates the object (BACnet) or register (Modbus) values accordingly. The LCD displays the sensor values as determined by the display mode object for either temperature only, RH only, both or none. Temperature units can be set to either C or F and the display resolution can be set also.

If the device has the optional Up/Down setpoint switches installed, pressing either the <UP> or <DOWN> keys will cause the LCD to change to show the setpoint value. The first key press will display the current setting of the Up/Down control for about 5 seconds and then revert back to the sensor values again if neither the <UP> or <DOWN> keys are pressed again. To increase the setpoint, press the <UP> key while the LCD is in setpoint mode and each press will increase the setpoint up to the maximum value. To decrease the setpoint, press the <DOWN> key while the LCD is in setpoint mode and each press will decrease the setpoint down to the minimum value. After 5 seconds of no key activity, the display will revert back to normal and the new setpoint value will be saved.

The setpoint minimum and maximum values can be configured via the network as can the units for either °C, °F or %RH values.

If the device has the optional Override switch installed, pressing the <OVERRIDE> key will cause the Override object status to change and it can be reset via the network.

Network objects are available to control the OCC (occupied) LCD segment and the relay output.

If the optional Fan Speed switch is installed, and if the optional D input is installed, it's output setting can be queried via a network object also.

Shorting the optional D Input terminal to COMMON will cause the DI BACnet object or Modbus register status to change.

More details on the above features can be found in the following sections.

SETUP

Press and release the <MENU> key to enter the SETUP menu

1. Network Protocol



Use <UP> or <DOWN> to select either bAC (BACnet) or bUS (Modbus) protocol. Press <SAVE> to save the value. The default is bAC (BACnet)

Press <MENU> to save and advance.

2. Network Address



Press <UP> or <DOWN> to select a unique network address. It can be set from 1-255 for Modbus or from 0-127 for BACnet. The default address is 3. Press <SAVE> to save the setting and advance the menu.

Press <MENU> to save and advance.

3. Baud Rate



Use <UP> or <DOWN> to select a baud rate of 30 (300), 60 (600), 120 (1200), 240 (2400), 480 (4800), 960 (9600), 192 (19200) or 384 (38400) for Modbus or 960 (9600), 192 (19200), 384 (38400) or 768 (76800) for BACnet. The default baud rate is 960 (9600). Press <SAVE> to save the setting and advance the menu.

Press <MENU> to save and advance.

Modbus Device Only

4. Parity



Use <UP> or <DOWN> to select a parity value of n (none), O (odd) or E (even). The default Modbus parity bit is n (none). Press <SAVE> to save the value.

Press <MENU> to save and advance.

5. Stop Bits



Use <UP> or <DOWN> to set the stop bits to 1 or 2. The default Modbus stop bits is 1.

Press <MENU> to save and advance.

6. CRC



Use <UP> or <DOWN> to select a CRC value of 1 (A001 = CRC-16 reverse), 2 (1021 = CITT), 3 (8005 = CRC-16) or 4 (8408 = CITT reverse). The default CRC is 1 (polynomial is 0XA001).

Press <MENU> to save and advance.

7. Delay



Use <UP> or <DOWN> to change the value from 0 (minimum) to 50, 100, 150, 200, 250, 300 or 350 ms. The factory default slave response delay is 0 (minimum). Minimum delay means just more than 3.5 character time delays, 4ms for 9600 baud rate, for example.

Press <MENU> to return to normal operation

SPECIFICATIONS

General Specifications

Power Supply	20-28 Vac/dc (non-isolated half-wave rectified)
Consumption	35 mA max @ 24 Vdc
Protection Circuitry.....	Reverse voltage protected, overvoltage protected
Operating Conditions	0 to 55°C (32 to 131°F), 0 to 95 %RH non-condensing
Wiring Connections.....	Screw terminal block (14 to 22 AWG)
Sensor Coverage Area.....	100 m ² (1000 ft ²) typical
Enclosure	Wall mount enclosure, 84 mm W x 119 mm H x 29 mm D (3.3" x 4.7" x 1.15")

Interface

Hardware	2-wire RS-485
Software.....	Native Modbus or BACnet® MS/TP protocol
Baud Rate	Locally set from 300 to 76800
Slave Address Range	Modbus: 1-255 (factory default is 3), BACnet®: 0-127 (factory default is 3) Locally Set (127 devices max on one daisy chain)

LCD Display

Resolution	0.1/0.5°/1.0°C or 0.1/0.5°/1°F (selectable), 1 %RH
Size.....	38.1 mm W x 16.5 mm H (1.5" W x 0.65" H) 3 digit
Backlight.....	Auto-dimming, enable or disable via jumper

Temperature Signal

Sensing Element.....	10K thermistor, ±0.2°C (±0.4°F)
Range.....	0 to 50°C (32 to 122°F)

Optional RH Signal

Sensor	Thermoset polymer based capacitive
Accuracy	±2 %RH
Range.....	0 to 100 %RH, non- condensing
Resolution	1 %RH
Hysteresis	±3 %RH
Response Time	15 seconds typical
Stability	±1.2 %RH typical @ 50 %RH in 5 years

Optional Relay Output

Contact Ratings.....	Form A contact (N.O.), 5 Amps @ 250 Vac, 5 Amps @ 30 Vdc for Resistive loads 2 Amps @ 250 Vac, 2 Amps @ 30 Vdc for Inductive loads
Relay Control.....	Via BACnet® or Modbus

Optional Setpoint Control

User Interface.....	Front panel push-button available via BACnet® or Modbus
Setpoint Mode.....	Temperature (°C/°F) or RH, menu selectable (factory default is Temp & °C)
Adjustable Range	10 to 50°C, 50 to 122°F or 10 to 85 %RH, menu selectable (factory default is 18 to 24°C)
Minimum Span.....	4°C/°F for 10 %RH
Temperature Resolution	0.5° or 1°, menu selectable (factory default is 1°)

Optional Override Switch..... Front panel push-button available via BACnet® or Modbus

Optional Fan Speed Switch..... Off, Auto, Low, Medium, High via BACnet® or Modbus

Digital Input Signal

Dry-contact only (relay contact), short to COMMON to activate

Country of Origin..... Canada

DIMENSIONS

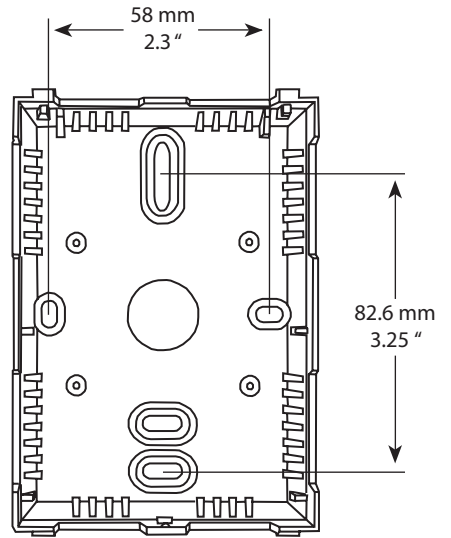
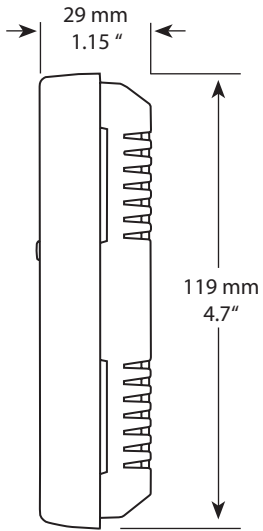
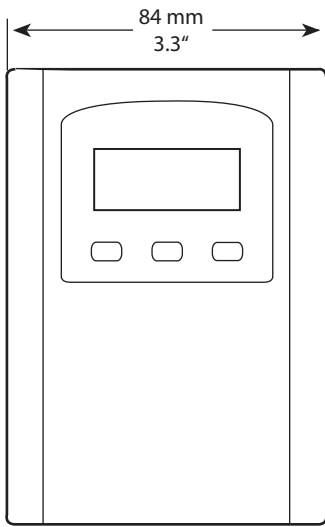

NETWORK SETUP GUIDE

The network setup guide describes the implementation of the BACnet® for Modbus protocol. It is intended to assist control system programmers who may need to add support to their systems to communicate with this device.

BACnet® and Modbus setup guide downloads are available online.



BACnet® PROTOCOL

<http://downloads.greystoneenergy.com/Website%20Documents/NTRC/SG-NTRCXXXBAC-01-01.pdf>



MODBUS PROTOCOL

<http://downloads.greystoneenergy.com/Website%20Documents/NTRC/SG-NTRCXXXMOD-01-01.pdf>