

INTRODUCTION

The probe replacement sensor module is a pre-calibrated humidity and temperature module that can be used for field replacement of the HS & HN Series duct (DT) and outside air (OB) humidity series sensors.

The sensors are incorporated in a porous filter that makes field replacement easy.

BEFORE INSTALLATION

Read these instructions carefully before installing and commissioning the water detector. Failure to follow these instructions may result in product damage. Do not use in an explosive or hazardous environment, with combustible or flammable gases, as a safety or emergency stop device or in any other application where failure of the product could result in personal injury. **Take electrostatic discharge precautions during installation and do not exceed the device ratings.**

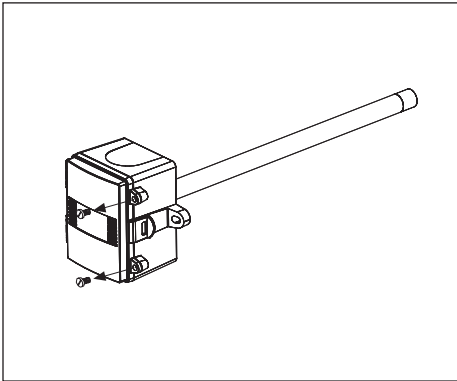
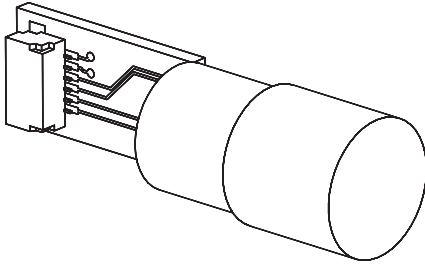

1 Remove security screws (if applicable) and open enclosure.

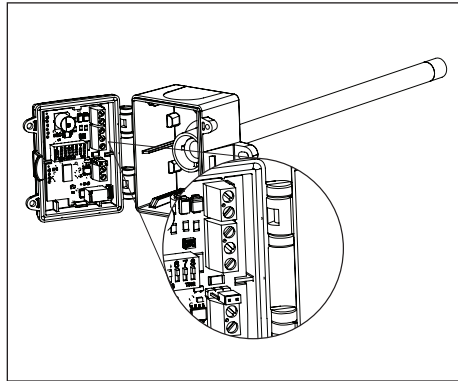

2 Disconnect power wires.

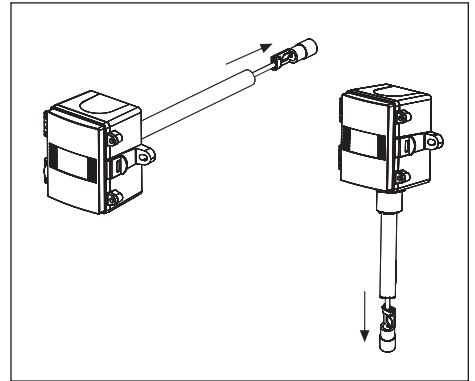

3 Carefully pull filter from the probe end so sensor PCB is exposed.

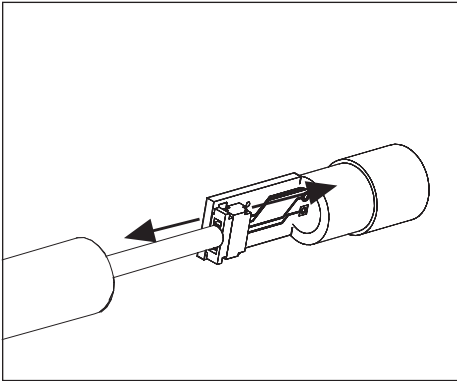

4 Unplug sensor PCB from harness.

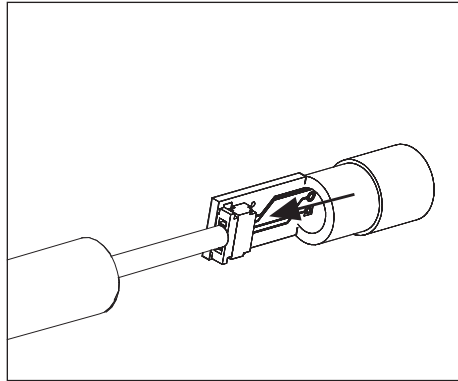

5 Install replacement module by plugging harness into sensor PCB.

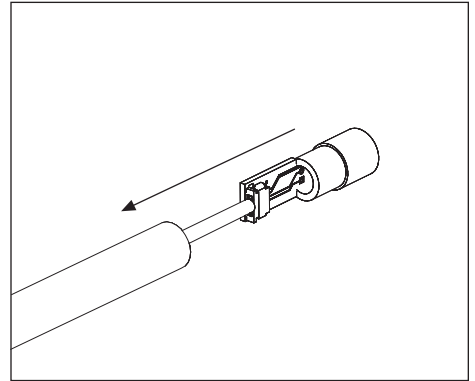

6 Carefully insert sensor PCB/filter assembly into probe.

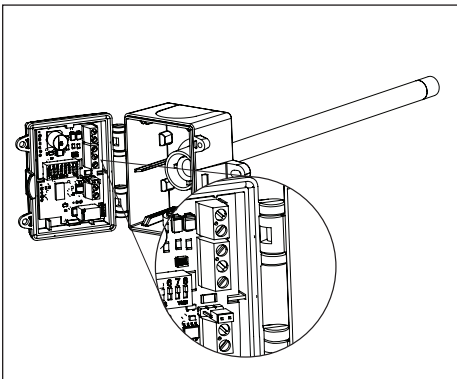

7 Reinstall power wires and apply power.

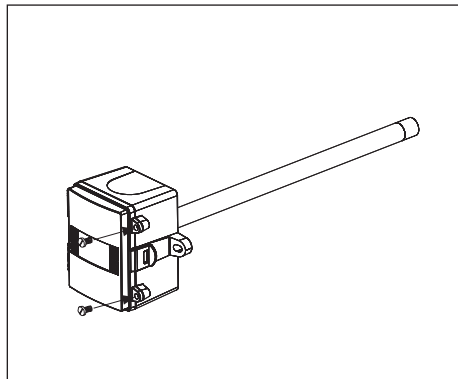

8 Close enclosure and reinstall security screws (if applicable).