

INTRODUCTION

The duct RH/T network sensor uses a highly accurate and reliable Thermoset Polymer based capacitance humidity sensor and curve-matched NTC thermistor temperature sensor together with state-of-the-art digital linearization and temperature compensated circuitry to monitor humidity and temperature levels in a duct and transmit values via Modbus communication to a building automation system. The sensors are encapsulated in a 60 micron HDPE filter at the end of a 230 mm (9") S/S probe and a compact enclosure.

BEFORE INSTALLATION

Read these instructions carefully before installing and commissioning the RH/T sensor. Failure to follow these instructions may result in product damage. Do not use in an explosive or hazardous environment, with combustible or flammable gases, as a safety or emergency stop device or in any other application where failure of the product could result in personal injury. **Take electrostatic discharge precautions during installation and do not exceed the device ratings.**

MOUNTING

The RH/T sensor installs directly into any air duct with a minimum width/diameter of 25.5 cm (10"). Select a suitable installation area in the middle of the duct wall. To achieve the best reading, do not place in an area where air stratification may be present. **Mount the sensor at least 1.5 m (5') in either direction from elbows, dampers, filters or other duct restrictions. Avoid areas where the transmitter is exposed to vibrations or rapid temperature changes.**

Once a suitable spot is selected, drill a 15 -20 mm (0.6" - .75") hole for the probe.

Slide the probe in the drilled hole until the enclosure is flush against the duct. The airflow direction is not important. Secure the enclosure to the duct with (2) #10 x 1" (25 mm) self tapping screws (Not provided). Tighten screws until the enclosure is tight against the duct and there is no movement of the enclosure as shown in Figure 1.

A foam gasket is provided on the back of the enclosure that provides a tight seal against any air leaks.

Using a Phillips screwdriver, remove the (2) cover screws, as shown in Figure 2. Remove cover and set aside with screws for re-installing after wiring and set up.

Two 21 mm (0.8125") holes are provided for connection of either 12.77mm (0.5") EMT or a cable gland style connector as shown in Figure 3. Insert the EMT or cable gland connector through the hole and securely fasten using a locknut. If only one connection hole is required, use the included hole plug to cap off the unused one as shown in Figure 4. Special care must be taken not to damage any internal components during installation.

Make wire connections as per the "Wiring" illustrations on Page 2.

Once wiring and set up are complete, re-install cover and tighten the (2) screws using a Phillips screwdriver.

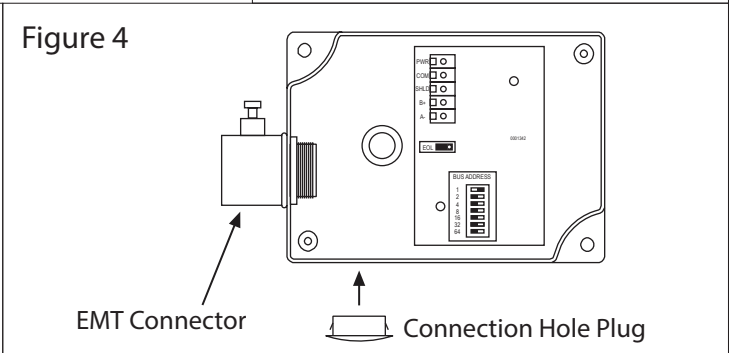
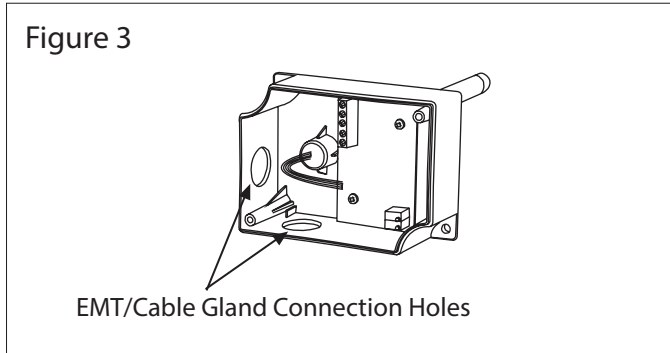
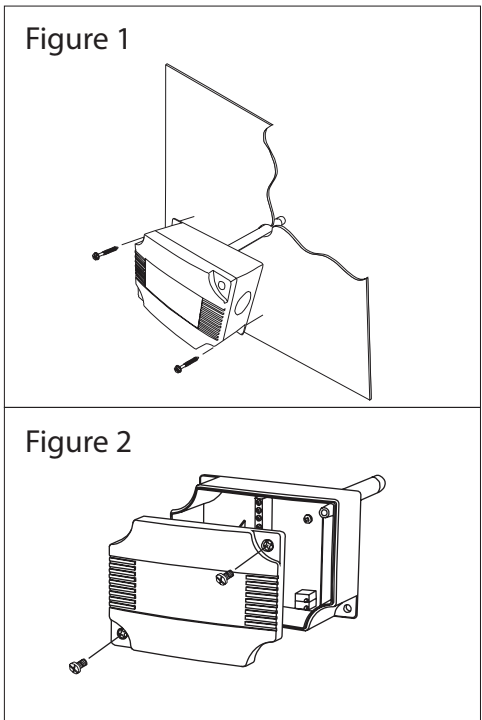

WIRING

Deactivate the 24 Vac/dc power supply until all connections are made to the device to prevent electrical shock or equipment damage. Follow proper electrostatic discharge (ESD) handling procedures when installing the device or equipment damage may occur. Use 22 AWG shielded wiring for all connections and do not locate the device wires in the same conduit with wiring used to supply inductive loads such as motors. Make all connections in accordance with national and local codes.

Connect the 24 Vac/dc power supply to the terminals labeled PWR (power) and COM (common) as shown in Figure 6. This device has a half-wave type power supply so use caution when wiring multiple devices so that the circuit ground point is the same on all devices and the controller. Use caution if 24 Vac power is used and one side of the transformer is earth-grounded. In general, the transformer should NOT be connected to

Figure 5

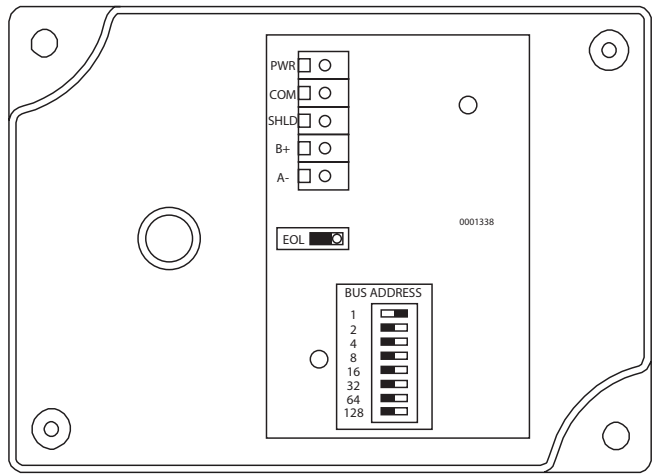
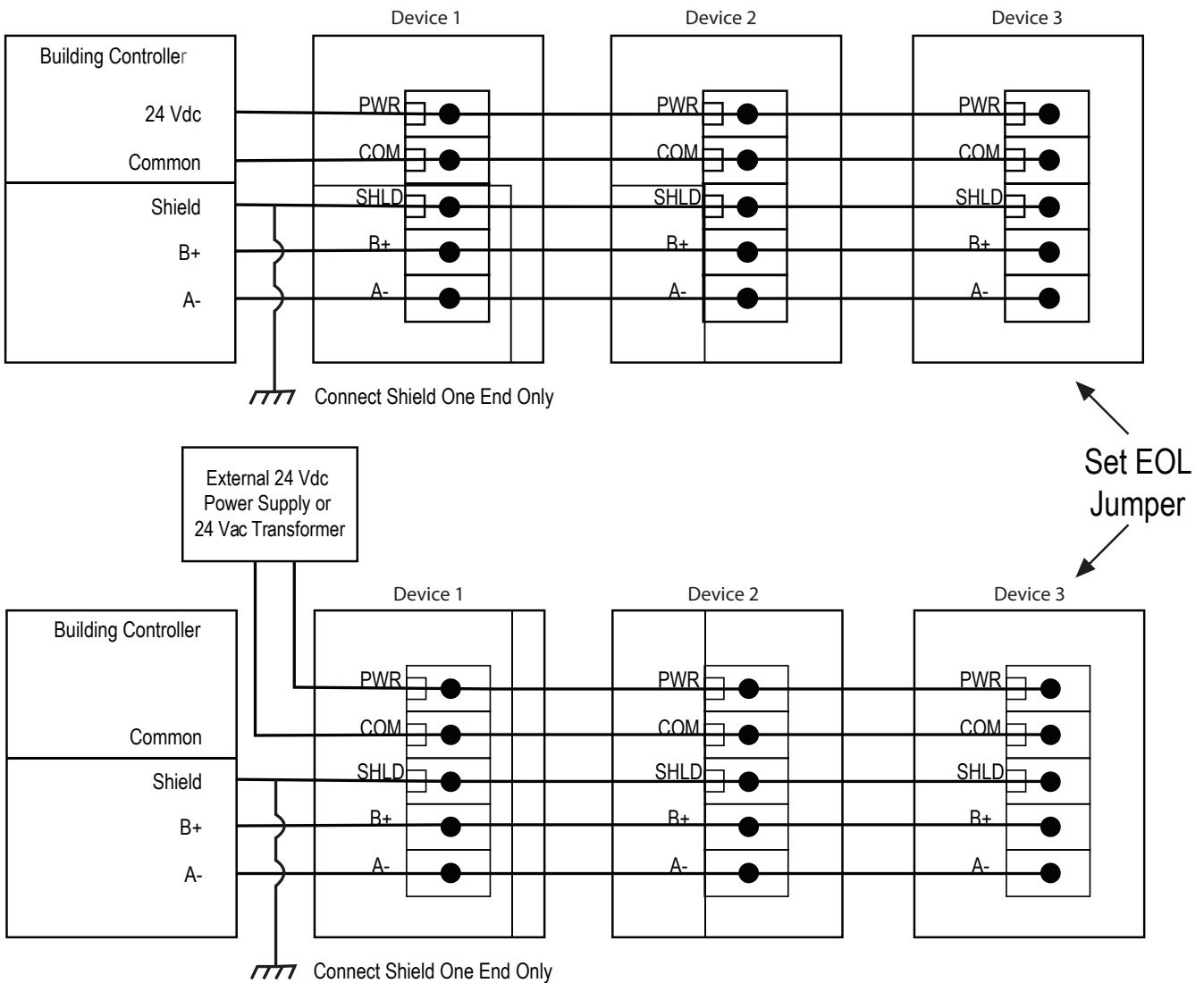

Figure 6



earth ground when using devices with RS-485 network connections. The device is reverse voltage protected and will not operate if connected backwards.

Connect the RS-485 network with twisted shielded pair to the terminals marked A-, B+ and SHLD (shield) as shown in Figure 6. The positive wire connects to B(+) and the negative wire connects to A(-) and the cable shield must be connected to the SHLD terminal

Figure 7

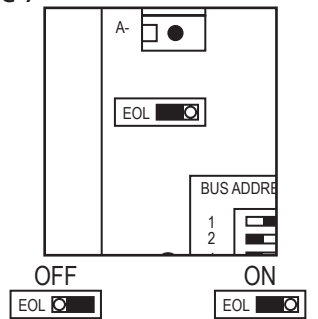

on each device. If the device is installed at either end of the network, an end-of-line (EOL) termination resistor (121 ohm) should be installed in parallel to the A(-) and B(+) terminals. This device includes a network termination jumper and will connect the resistor correctly on the pcb. Simply move the pcb jumper to the EOL position and no external resistor is required as shown in Figure 7. The ground wire of the shielded pair should be connected to earth ground at the end of the network and the master is not grounded. Do not run bus wiring in the same conduit as line voltage wiring.

A network segment is a single shielded wire loop run between several devices (nodes) in a daisy chain configuration. The total segment length should be less than 4000 feet (1220 meters) and the maximum number of nodes on one segment is 127. Nodes are any device connected to the loop and include controllers, repeaters and sensors such as the RH/T Sensor but does not include the EOL terminators. To install more devices, or to increase the network length, repeaters will be required for proper communication. The maximum daisy chain length (segment) depends on transmission speed (baud rate), wire size and number of nodes. If communication is slow or unreliable, it may be necessary to wire two daisy chains to the controller with a repeater for each segment.

NETWORK COMMUNICATION

Each device must have a unique ModBus address for startup and it must be set before connection to the network. The local DIP switch is used to set the ModBus device address (1-255). Set the device address as shown in Figure 8.

Figure 8

DIP Switch Position							BACnet® Address
64	32	16	8	4	2	1	
OFF	OFF	OFF	OFF	OFF	OFF	OFF	0
OFF	OFF	OFF	OFF	OFF	OFF	ON	1
OFF	OFF	OFF	OFF	OFF	ON	OFF	2
OFF	OFF	OFF	OFF	OFF	ON	ON	3
ON	ON	ON	ON	ON	ON	OFF	126
ON	ON	ON	ON	ON	ON	ON	127

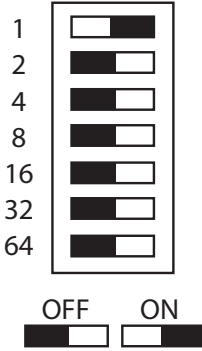

The factory default network configuration is:

Baud Rate 38400
 Parity None
 Stop Bits 1
 CRC A001 (CRC-16 reverse)
 Delay 0 (minimum)

Note that the ModBus network configuration may be customized at the factory if required. For example, the baud rate and other parameters may be factory configured to suit specific applications.

The RH/T Sensor operates as a slave. It will not communicate unless a master is connected to the network and sends a request for information, then the slave will answer. If the device does not communicate properly, first check that the communication wires are not reversed. Then check that the slave address has a unique setting for the network segment it is connected to. Finally, verify that the device baud rate, parity bit, stop bit and RTU mode CRC polynomial are correct for the network it is connected to.

SPECIFICATIONS

General Specifications

Power Supply	24 Vac/dc \pm 10% (non-isolated half-wave rectified)
Consumption	35 mA max @ 24 Vdc
Protection Circuitry	Reverse voltage protected, overvoltage protected
Operating Conditions	-40 to 50°C (-40 to 122°F), 0 to 95 %RH non-condensing
Enclosure	ABS, UL94-V0, IP61 (NEMA 2)
Dimensions	114mm W x 84mm H x 53mm D (4.5" x 3.3" X 2.1")
Wiring Connections	Screw terminal block (14 to 22 AWG)
Sensing Probe	230mm (9") long x 12.7mm (1/2") diameter stainless steel probe with porous filter
Sensor Coverage Area	100 m ² (1000 ft ²) typical
Country of Origin	Canada

Interface

Hardware	2-wire RS-485
Software	Native Modbus MS/TP protocol
Baud Rate	38400
Network Address Range	Locally set to 1-255
Parity	None
Stop Bits	1
CRC	A001 (CRC-16 reverse)

Temperature Signal

Sensing Element	20K Ω NTC thermistor
Accuracy	\pm 0.1°C (\pm 0.18°F) curve matched
Range	-40 to 50°C (-40 to 122°F)
Resolution	0.1°C/°F

RH Signal

Sensor	Thermoset polymer based capacitive
Accuracy	\pm 2 %RH
Range	0 to 100 %RH
Resolution	0.1 %RH
Hysteresis	\pm 1.5 %RH
Response Time	15 seconds typical
Stability	\pm 1.2 %RH typical @ 50 %RH in 5 years

DIMENSIONS

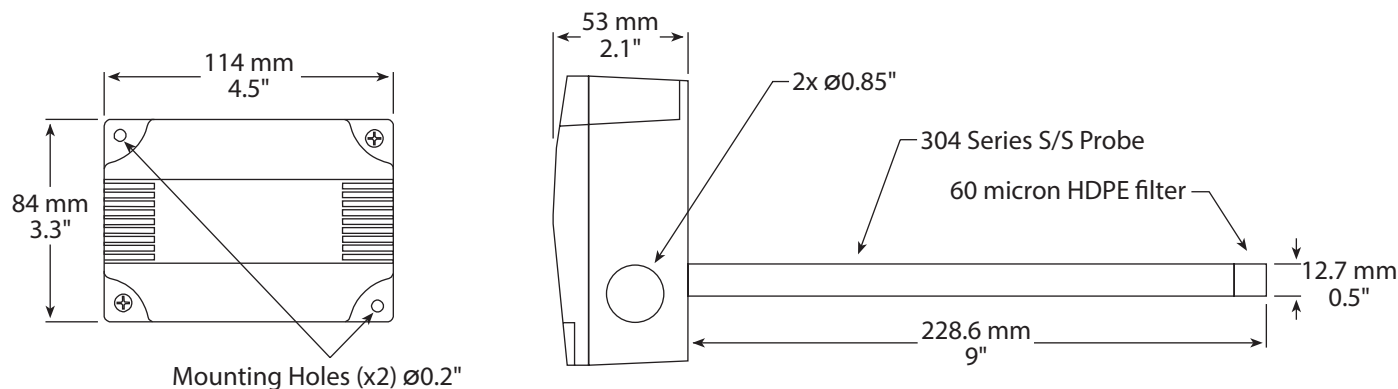

NETWORK SETUP GUIDE

The network setup guide describes the implementation of the Modbus protocol. It is intended to assist control system programmers who may need to add support to their systems to communicate with this device.

Modbus setup guide download is available online.



Modbus PROTOCOL

<http://downloads.greystoneenergy.com/SG/SG-NTRCXXXMOD.pdf>