

INTRODUCTION

The high accuracy duct humidity/temperature transmitter series uses a highly accurate and reliable Thermoset Polymer based capacitance humidity sensor and Platinum RTD temperature sensor together with state-of-the-art digital linearization and temperature compensated circuitry to monitor humidity levels in a duct. The sensors are encapsulated in a 60 micron HDPE filter at the end of a 230 mm (9") S/S probe and a compact enclosure.

BEFORE INSTALLATION

Read these instructions carefully before installing and commissioning the humidity/temperature transmitter. Failure to follow these instructions may result in product damage. Do not use in an explosive or hazardous environment, with combustible or flammable gases, as a safety or emergency stop device or in any other application where failure of the product could result in personal injury. **Take electrostatic discharge precautions during installation and do not exceed the device ratings.**

MOUNTING

The transmitter installs directly into any air duct with a minimum width/diameter of 25.5 cm (10"). Select a suitable installation area in the middle of the duct wall. To achieve the best reading, do not place in an area where air stratification may be present. Mount the sensor at least 1.5 m (5') in either direction from elbows, dampers, filters or other duct restrictions. Avoid areas where the transmitter is exposed to vibrations or rapid temperature changes.

Once a suitable spot is selected, drill a 15 -20 mm (0.6" - .75") hole for the probe.

Slide the probe in the drilled hole until the enclosure is flush against the duct. The airflow direction is not important. Secure the enclosure to the duct with (2) #10 x 1" (25 mm) self tapping screws (not provided). Tighten screws until the enclosure is tight against the duct and that there is no movement of the enclosure as shown in Figure 1.

A foam gasket is provided on the back of the enclosure that provides a tight seal against any air leaks.

The enclosure has a hinged cover with a latch. Open the cover by pulling slightly on the latch on the right side of the enclosure. At the same time pulling on the cover, as illustrated in Figure 2.

A 1/2" NPT threaded connection hole is provided in the bottom of the enclosure. Screw the EMT or cable gland connector in until tight. See Figure 3. It is recommended that weatherproof EMT or cable gland fittings be used. The E style enclosure includes 1/2" NPT to M16 thread adapter and cable gland fitting.

Make wire connections as per the "Wiring" illustrations on Page 2.

Swing door closed until securely latched. For added security, 2 screws are provided that may be installed in the integrated screw tabs. See Figure 4.

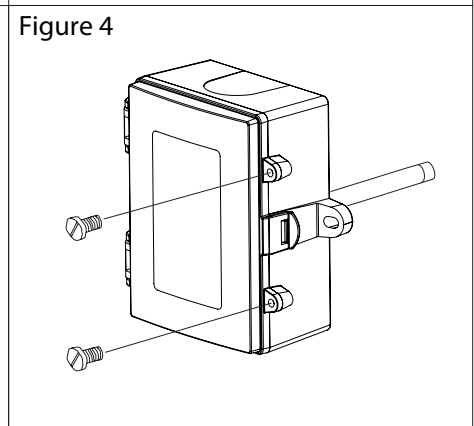
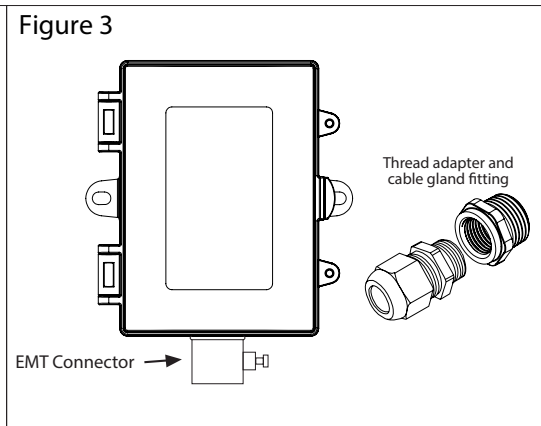
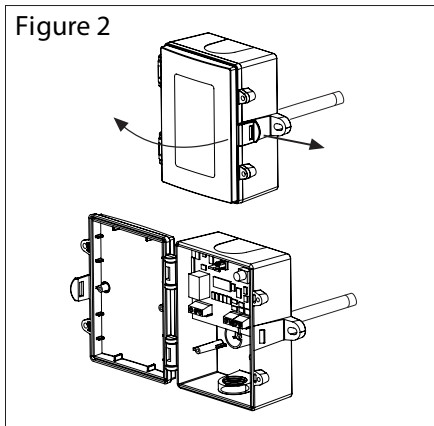
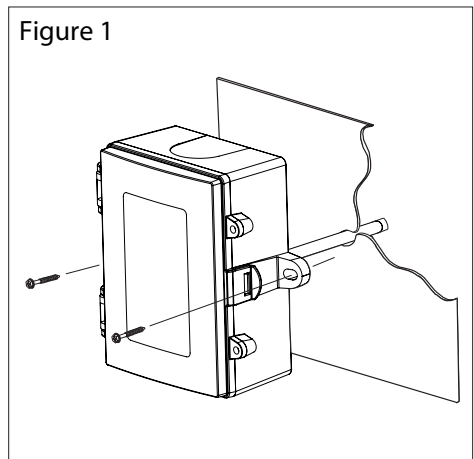

WIRING

- Deactivate the 24 Vac/dc power supply until all connections are made to the device to prevent electrical shock or equipment damage.
- Use 14-22 AWG shielded wiring for all connections and do not locate the device wires in the same conduit with wiring used to supply inductive loads such as motors. Make all connections in accordance with national and local codes.
- Pull at least six inches of wire into the enclosure, then complete the wiring connection according to the wiring diagram for the applicable power supply and output signal type.
- Connect the plus DC or the AC voltage hot side to the PWR terminal. For voltage output or AC power, the supply Common is connected to the COM terminal. The device is reverse voltage protected and will not operate if connected backwards. It has a half-wave power supply so the supply Common is the same as the signal Common. See Figure 5.
- The analog outputs are designated as TEMP and RH by each terminal. Check the controller Analog Input to determine the proper connection before applying power. See Figure 5.

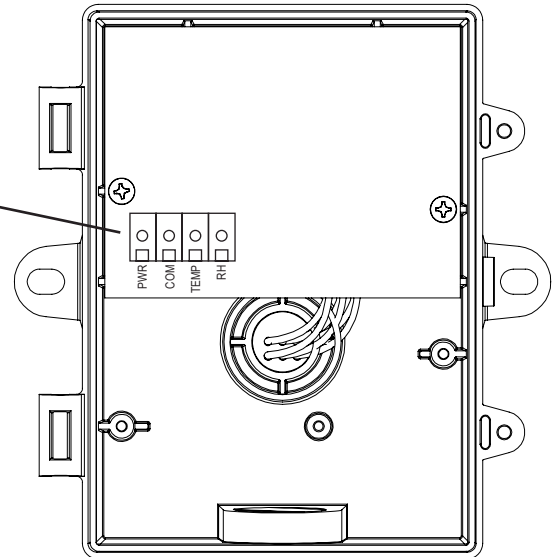
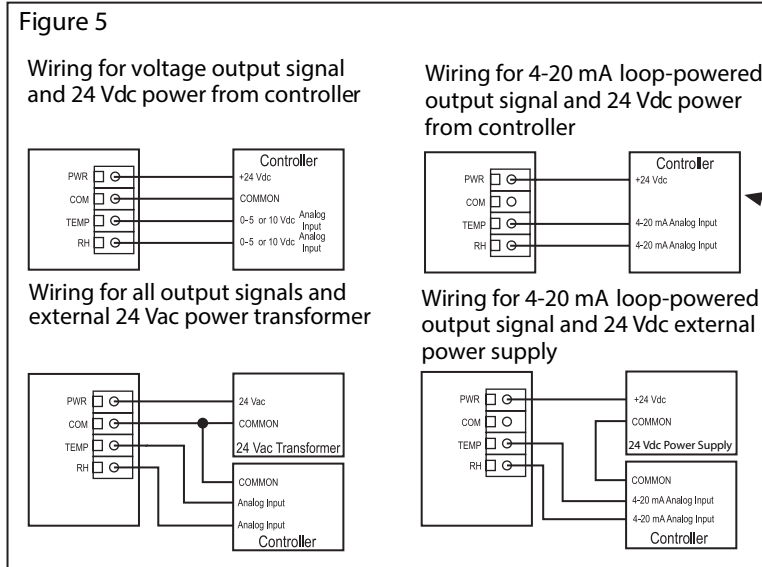

SPECIFICATIONS:

Humidity Sensor Type	Thermoset Polymer based capacitive
Accuracy	±1% (20 to 80% RH) or ±2% (5 to 95% RH)
Measurement Range.....	0 to 100% RH
Hysteresis	±1.5% RH maximum
Repeatability	±0.5% RH typical
Linearity.....	±0.5% RH typical
Sensor Response Time.....	15 seconds typical
Stability	±1% RH typical at 50% RH in 5 yrs.
Temperature Sensor Type.....	1000Ω Platinum, IEC 751, 385 Alpha, thin film
	RTD Class A: ±0.15°C (±0.27°F) @ 0°C (32°F)
	RTD 1/3 DIN: ±0.1°C (±0.18°F) @ 0°C (32°F)
	RTD 1/10 DIN: ±0.03°C (±0.054°F) @ 0°C (32°F)
Temperature Accuracy.....	±0.1% of span
Operating Temperature.....	-40° to 50°C (-40° to 122°F)
Operating Humidity	0 to 95% RH non-condensing
Power Supply	18 to 35 Vdc, 15 to 26 Vac
Consumption	22 mA maximum
Input Voltage Effect	Negligible over specified operating range
Protection Circuitry.....	Reverse voltage protected & output limited
Output Signals.....	4-20 mA, 0-5 or 0-10 Vdc
Output Drive at 24 Vdc	550 ohms max for current output, 10K ohms min for voltage output
Internal Adjustments	Clearly marked ZERO and SPAN pots
Wiring Connections.....	Screw terminal block (14 to 22 AWG)
Enclosures	B: Grey polycarbonate with gasket, UL94-V0 IP65 (NEMA 4X) F: Same as B, with thread adapter (1/2" NPT to M16) and cable gland fitting
Probe.....	117 W x 102 H x 53 D mm (4.6" x 4.0" x 2.1") 230 mm (9") probe length x 12.7 mm (1/2") diameter stainless steel with porous filter
Weight	220g (7.8 oz) including Probe.
Country of Origin.....	Canada

DIMENSIONS

