

### INTRODUCTION

The analog isolation module is a 2 wire loop-powered 4-20 mA signal isolator with one input/output channel. It will accept one analog current or voltage input signal, isolate it and sink a current output signal. The input has several fixed ranges for various applications.

The device derives operating power from the output current loop that is provided by the receiving device and has an on-board transformer that provides complete input/output signal isolation.

Both the input and output are sinking type and the input signal types are easily selected with DIP switches.

The product comes with standard snap-track for easy mounting

### BEFORE INSTALLATION

Read these instructions carefully before installing and commissioning the device. Failure to follow these instructions may result in product damage. Do not use in an explosive or hazardous environment, with combustible or flammable gases, as a safety or emergency stop device or in any other application where failure of the product could result in personal injury. **Take electrostatic discharge precautions during installation and do not exceed the device ratings.**

### MOUNTING

The snap-track device may be mounted in any position. Use only fingers to remove the PCB from the snap-track, do not pry on the PCB with tools. Do not flex the PCB during removal or installation. Slide the PCB out of the snap-track or push against one side of the snap-track and lift the PCB out. See Figure 1. Ensure any metallic mounting hardware does not contact the underside of the PCB.

Avoid mounting in areas where the device is exposed to vibrations or rapid temperature changes. Mount the snap track with the PCB removed using two screws as shown in Figure 2.

Once the snap track is mounted, place the bottom part of the PCB into the bottom track and gently press on the top corners of the PCB until it snaps into place in the top track, see Figure 4.

Figure 1

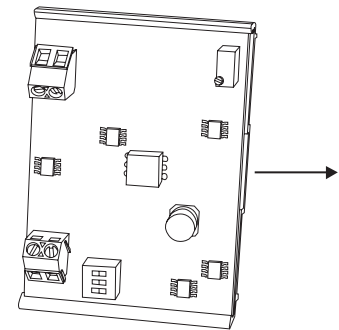

Figure 2

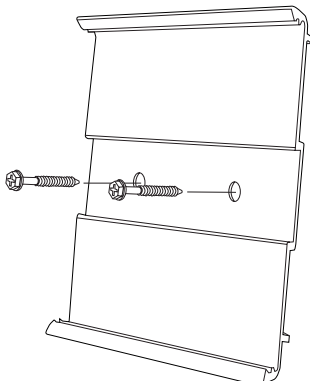
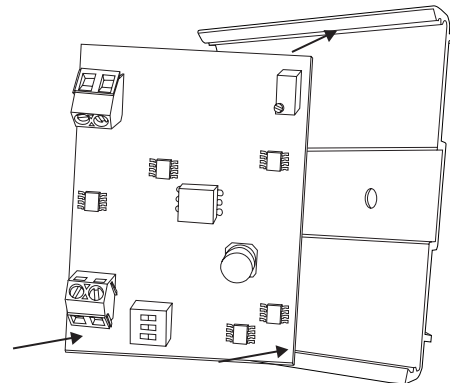
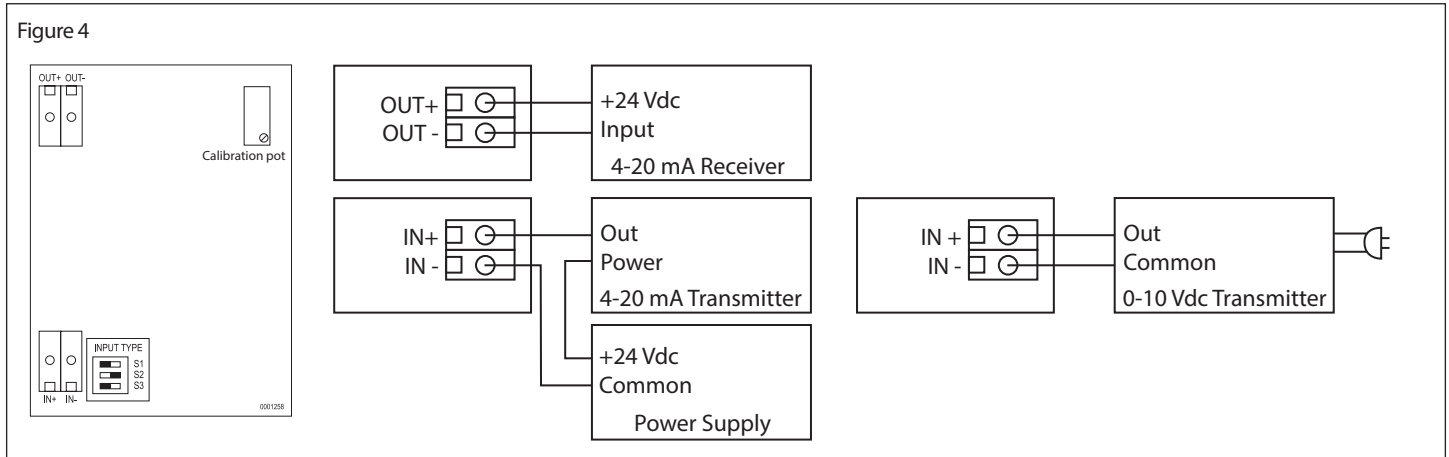

Figure 3



## WIRING

- Deactivate any power supplies until all connections are made to the device to prevent electrical shock or equipment damage.
- Follow proper electrostatic discharge handling procedures when installing the device.
- Use 22 AWG shielded wiring for all connections and do not locate the device wires in the same conduit with wiring used to supply inductive loads such as motors.
- Make all connections in accordance with national and local codes.
- The analog input signal is connected to the IN+ and IN- terminals and the analog output signal is connected to the OUT+ and OUT- terminals. The input and output signals are completely isolated from each other.



Study the wiring diagrams for proper connections with various input/output signal types and with both sinking or sourcing applications.

## FACTORY CONFIGURATIONS

The Isolation Module is preset for 4-20 mA input / 4-20 mA output. The input signal may be changed by using the DIP switches as shown in Figure 5.

## CALIBRATION

The isolator is factory calibrated to  $\pm 0.1\%$  accuracy on the 0-5 vdc input type. Using any other range will result in a transfer accuracy or  $\pm 1\%$ . If a higher accuracy signal is required simply apply the full-scale input signal and adjust the output signal to 20.00 mA using the calibration pot.

Figure 5

Input Signal Type	S1	S2	S3
0-5Vdc	OFF	OFF	OFF
0-10 Vdc	OFF	ON	OFF
1-5 Vdc	OFF	OFF	ON
2-10 Vdc	OFF	ON	ON
0-20 mA	ON	OFF	OFF
4-20 mA	ON	OFF	ON

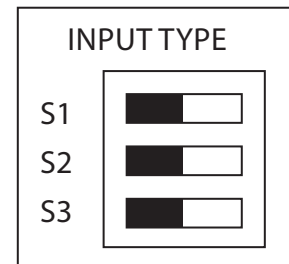

0-5 Vdc Shown

## SPECIFICATIONS

### GENERAL

Power Supply ..... Powered by loop-current (15-30 Vdc)  
 Isolation ..... 1000 Vrms input to output  
 Accuracy .....  $\pm 0.1\%$  typical  
 Operating Conditions ..... 0 to 50°C (32 to 122°F), 5 to 95 %RH non-condensing  
 Storage Conditions ..... -30 to 70°C (-22 to 158°F), 5 to 95 %RH non-condensing  
 Wiring Conditions ..... Screw terminal block (12 to 24 AWG)  
 Weight ..... 56gm (1.98 oz)  
 Enclosure ..... Snap track mounting, 61mm L x 83mm W (2.4" x 3.25")  
 Country of Origin ..... Canada

### INPUT SIGNAL

Input Voltage Ranges ..... 0-5, 0-10, 1-5, and 2-10 Vdc  
 Input Voltage Impedance ..... >10 K $\Omega$   
 Current Signal Type ..... Sink (external transducer generates 4-20 mA)  
 Input Current Ranges ..... 0-20 and 40-20 mA  
 Input Current Impedance ..... 250  $\Omega$

### OUTPUT SIGNAL

Output Current Range ..... 4-20 mA  
 Output Current Impedance ..... 750  $\Omega$  max with 24 Vdc supply  
 Current Signal Type ..... Sink (requires a loop power supply)

## DIMENSIONS

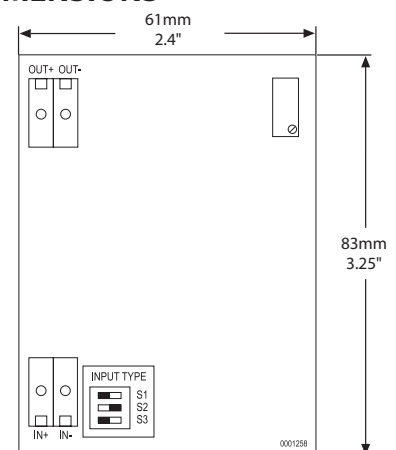

PRINTED IN CANADA