

### INTRODUCTION

The differential pressure switch housing unit contains a diaphragm, a snap-acting SPDT switch, and a range adjustment knob with increments. The sample connections located on the side accept 6.35mm (0.25") OD tubing. There are various optional pressure ranges, and 2 pickup tubes and 2 m (6.56') of PVC tubing available. The enclosure cover guards against accidental contact with the live switch terminal screws and the setpoint adjustment knob with indication.

### BEFORE INSTALLATION

**The electrical equipment may only be installed, added to, changed or maintained by authorized electricians.** No voltage is to be applied when you work on electrical installations.

### ELECTRICAL CONNECTIONS

Use a three wired cable with an outer diameter of 5-10mm for the electrical connection. Either tighten the screwed cable gland or insert a conduit tube with 1/2" thread and tighten with a torque of 2.5NM. See Figure 1.

The connections are intended for 6.3mm crimp-type-sockets. Assemble flex- and solid wires accordingly. See Figure 2.

The switch (P) in the pressure switch is designed as a change over contact. Pole 3 (COM) closes to pole 2 (NO) at increasing pressure and to pole 1 (NC) at decreasing pressure. See Figure 3. Protect the feed line to pole 3 (COM), either in the control system or along the line (F), as shown in Figure 4 as follows:

- Max. 1.0 A / 250 VAC 50-60 Hz, at ohmic consumers.
- Max. 0.4 A / 250 VAC 50-60 Hz, at inductive consumers.
- Max. 0.1 A / 24 VDC 50-60 Hz, at the low-voltage version.

### HOSE CONNECTIONS

**Hoses are not to be bent or damaged during mounting.** Leaking hoses and leaking hose connections cause disturbances on the device or inaccurate measurements. It is essential to remove the cap for transportation safety mounted on P2.

- Inner hose diameter = 5.5mm for optimal clamping
- P1 = Over pressure measurement (Bottom Port)
- P2 = Vacuum measurement (Top Port)
- P1 & P2 = Differential pressure measurement

### SWITCHING PRESSURE ADJUSTMENT

**Caution. Make absolutely sure that no voltage is applied to the electrical connections BEFORE any settings on the pressure switch are carried out.**

Set the desired pressure trip point (which trips at increasing pressure) using a flathead screw driver. The switch returns to its resting position as soon as the pressure falls below the set switching differential. See Figure 5.

Replace the cover on the switch as illustrated in Figure 6. Do not operate the system until the housing is closed. Check the trip and reset pressure by slowly increasing and decreasing pressure.

Figure 1

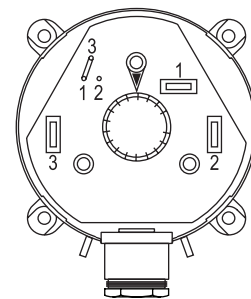

Figure 2

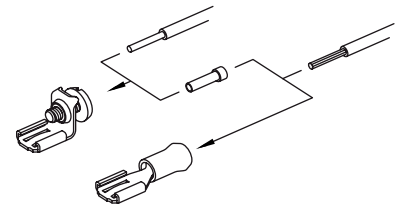

Figure 3

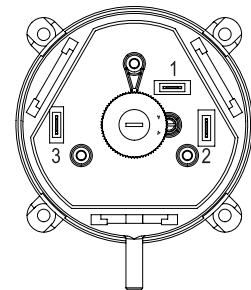

Figure 4

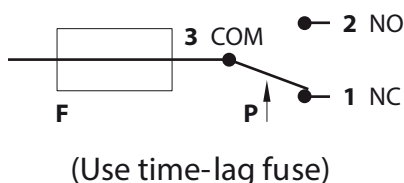

Figure 5

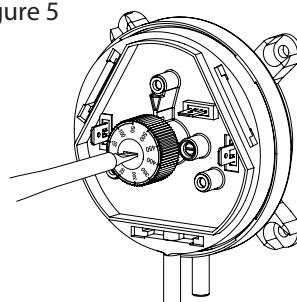
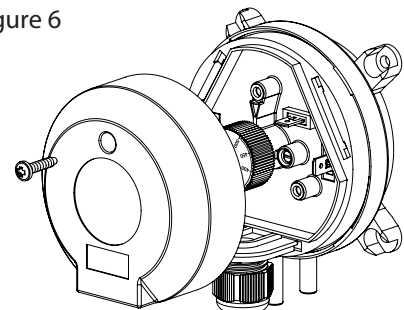

Figure 6



**MOUNTING**

**Important: Check the pressure switch for damages. Do not use if the switch is damaged. Do not mount the pressure switch on uneven surfaces. Do not over tighten the screws as it will deform the the device's base.**

Mount the pressure switch with the pressure connections pointing downwards, to drain condensation that may occur. Mount the pressure switch horizontally with electrical connectors pointing upward **only** if no condensate can form. In this position, the switching values are approximately 20 Pa higher as indicated.

In general using two screws for mounting is sufficient, as illustrated in Figure 7. The maximum diameter of the screw head cannot exceed 8mm.

**SAFETY & LIABILITY**

The existing safety regulations, the intended use and the technical data must be strictly observed. According to these regulations, plants must be zero-potential and secured against inadvertently restart. The product can not be used for U.S. FDA-controlled application areas. For damage caused by improper use no liability is assumed.

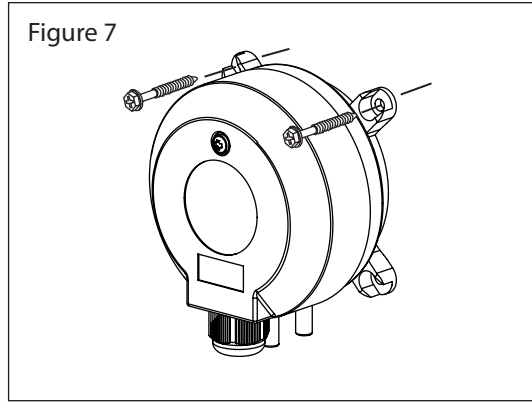

**SPECIFICATIONS**

Medium / Max. Operating Pressure .....	Air / 10 kPa for all pressure ranges
Temperature Range .....	<b>Medium and ambient temperature:</b> -20 to 60°C (-4 to 140°F)
	<b>Storage Temperature:</b> -40 to 85°C (-40 to 185°F)
Pressure Connectors.....	<b>P1 (+):</b> Connection to higher pressure
	<b>P2 (-):</b> Connection to lower pressure
Weight .....	With / without cover: 160g / 115g
Working Life .....	Over 10 <sup>6</sup> mechanical switching operations
Electrical Rating .....	<b>Standard Version:</b> Max. 1.0 A (0.4 A) / 250 VAC 50-60 Hz
	<b>Low-voltage Version:</b> Max. 0.1 A / 24 VDC
	<b>Switching Rate:</b> Max. 6 Cycles/min
Arrangement of Contacts .....	Break contact - NC
	Operating contact - NO
	Power supply line - COM
Protection Category .....	<b>With cover:</b> IP 54
Conformity .....	CE; ANSI; UL508; CSA C22.2#14
Country of Origin.....	Germany

**DIMENSIONS**

