



NOTE: In order to ensure optimum operating conditions the ESF sensor tip must be placed in the middle of the duct. To avoid airflow stratification's, which will adversely effect the sensor, the ESF should be placed at least 6 duct diameters in front of an obstruction or bend in the ducting, and not closer than 3 duct diameters behind an obstruction.

Specifications, ESF-35-2

Airflow speed. 0-8 m/s(1575 ft/m, 0-16 m/s(3150 ft/m)

Standard current signal 4-20 ma (RL<500Ω)

Standard voltage signal..... . 0-10V (max. 5mA)

Air temperature -10°C/+60°C (32 – 140F)

Ambient temperature-20°C/+50°C (-4 – 122F)

AC voltage supply 24 Vac ±10% (120 ma)

DC voltage supply 16-30 V dc (80 ma)

Absolute accuracy ±5%

Rise time 20 sec

Time constant 5 sec

Depth of insertion in channel50-200 mm (2-8 in.)

Dimen...(HxWxD)/80x80x55 mm(3.15x3.15x2.17 in)

Maintenance

As the thermal measuring principle is based on the cooling principle of the air, possible dirting of the sensor will reduce the measuring accuracy. If the transducer is used in unclean air, the sensor head should be cleaned at suitable intervals.

Range Setting

The ESF-35-2 is delivered with the range set at 0-8 m/sec (0-1575 ft/min).

If jumper SW1 is removed on the PCB, the range 0-16 m/sec (0-3150 ft/min) is obtained.

Application

The ESF is an airflow transducer which may be used for control, monitoring and regulation of airflow speed in fresh air and ventilation units etc.

Operation

The ESF-35-2 registers airflow speed according to a thermal principle based on the fact that the cooling action of air increases with airspeed. The action is measured and converted to a 4 to 20 ma or a 0-10V signal corresponding to airflow speeds from 0-8 m/s (0-1575 ft/min) or 0-16 m/s (0-3150 ft/min). The micro-processor based electronics ensures that the output signal is linear and corrects the output due to temperature changes. If a standard analog instrument is connected the airflow speed then the temperature can be read remotely. The transducer has separate a 0-10 Vdc output signal for measurement of the air temperature 0-50°C (32 – 122F).

In order for the transducer to operate correctly all the information supplied in this document must be followed.

Mounting

The ESF-35 is mounted in such a way that the airflow passes the sensor head. The power supply cables to the transducer should be kept separated from high voltage lines where heavy transients may occur.

The transducer can be mounted in airflow channels with a diameter or channel width of 100-370 mm (4 in – 15 in)

Wiring

The length of the cable is not critical. Avoid placing it in parallel with other cables, which may induce electrical noise on the voltage signal and thus disturb the function of the transducer.

The best installation is obtained with a separate cable to the transducer.

It is recommended to use a shielded cable to the transducer as this will improve the immunity of the transducer against noise when it is used in industrial areas. The shield should be terminated at the supply point but not terminated at the transducer.

Figures

- Fig. 1 Wiring connection diagram
- Fig. 2 Output signals scales
- Fig. 3 Dimensions

Figure 1

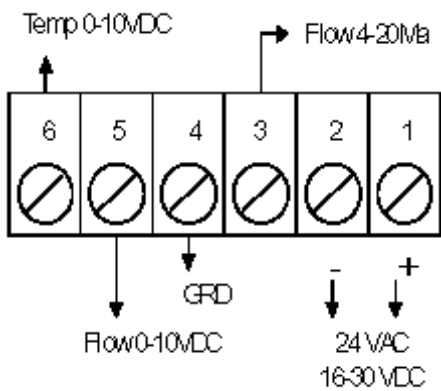

Figure 1

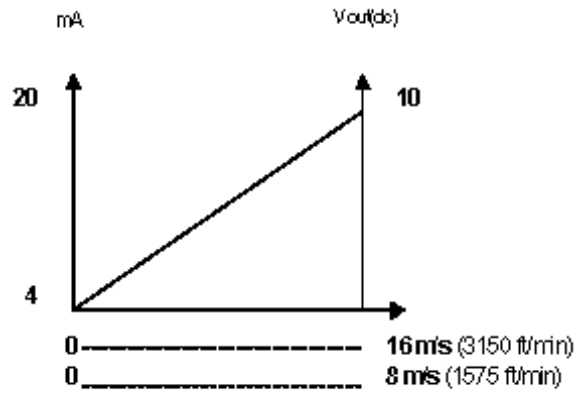

Figure 3

