

#### INTRODUCTION

The current sensor monitors line current for electrical loads such as pumps, conveyors, machine tools or fans and provides a 4-20 mA analog output to represent the load current.

The sensor is loop powered and requires an external 15-30 Vdc power supply. The power supply must be  $10 \text{ Vdc} + (\text{Rload} \times 20 \text{ mA})$  where Rload is the input resistance of the device measuring the signal. So if Rload is  $250 \Omega$  the minimum power supply is 15 Vdc. The measured AC line current can be calculated as  $I_{\text{line}} = (I_{\text{loop}} - 4 \text{ mA}) \times (I_{\text{range}} / 16)$ . The device is factory calibrated to  $< \pm 2\%$  FSO and features three switch-selectable current ranges.

The sensors are typically used to monitor AC motor operation and can be used to determine motor failure, belt loss, machine feed rates or tool wear.

#### \*WARNING\*

- **Electric shock hazard, use caution**
- Disconnect and lock out power before installation
- Follow national and local electrical codes
- Read and understand these instructions before installing
- Installation only by qualified electrical personnel
- Do not rely on this device to indicate line power
- Only install this device on insulated conductors
- Only install on 600 Vac maximum conductors
- Do not use this device for life-safety applications
- Do not install in hazardous or classified locations
- Install this product in a suitable electrical enclosure
- **Failure to follow these instructions will result in death or serious injury**

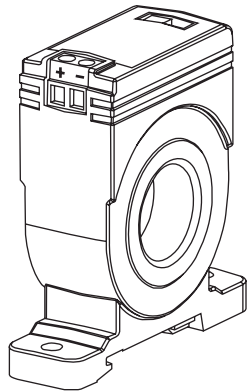

#### INSTALLATION

**Read all warnings before beginning installation of this device.** Ensure the selected device has the correct ratings for your application. Set the range switch to the desired range. See Figure 1. **Disconnect and lock out power.** Mount the sensor with two screws through the base or snap onto a standard DIN mounting rail.

The base has an integrated mounting tab to allow either screw mount to a surface or spring mount to a DIN rail.

To mount the device to a flat surface, select an area that will allow side and top access to wire device. Slide the mounting tab in so that both the mounting holes are accessible. If pre-drilling is required then the device may be used to mark holes on the mounting surface. The mounting holes in the base will accommodate up to a #10 size screw. (not supplied). See Figure 3.

For DIN rail mounting, first slide the mounting tab to its outer position and then hook the fixed end to the DIN rail and finally the tab end may be snapped onto the rail. The tab may be pulled out slightly to allow easier mounting or to remove the device from the rail. See Figure 4.

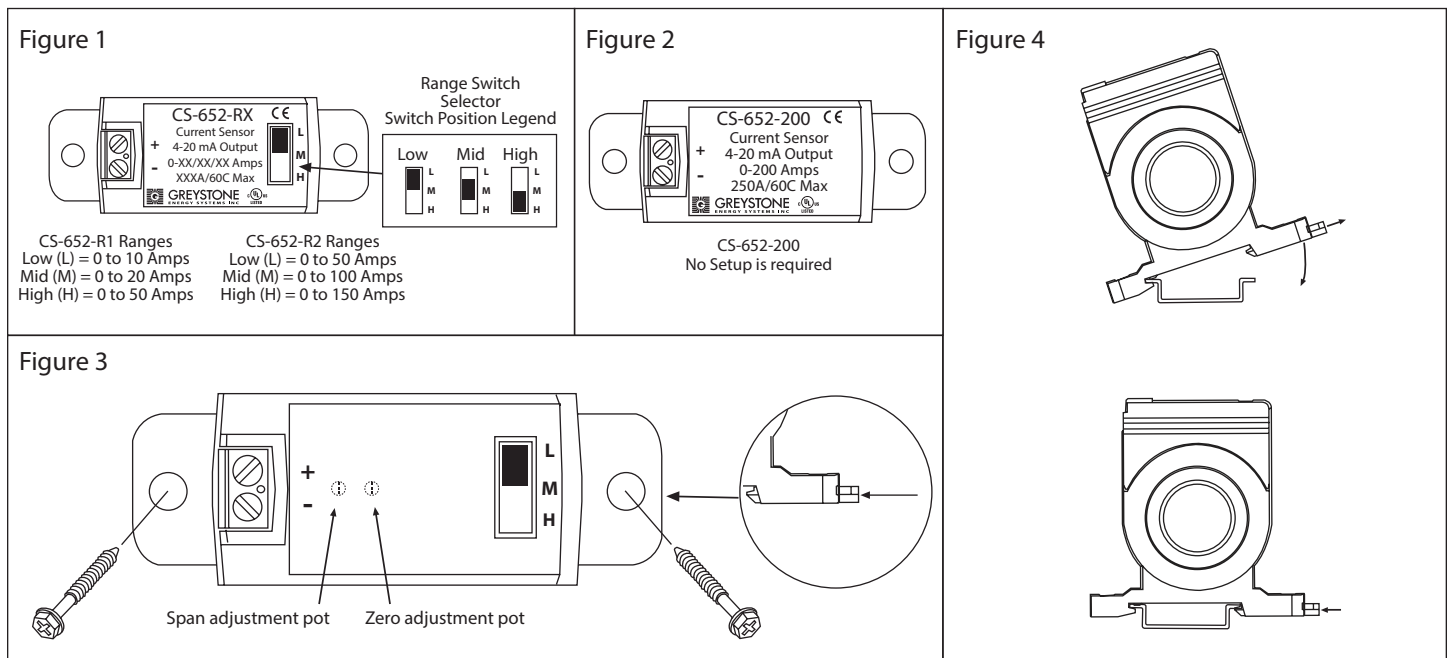

Place the monitored conductor (must be insulated) through the sensor hole and reconnect. See Figure 5. Observe polarity and wire the output to the controller. Use 14-22 AWG shielded wiring for all connections and do not locate the device wires in the same conduit with wiring used to supply inductive loads such as motors. Make all connections in accordance with national and local codes. See Figure 6. Ensure the controller scale matches the sensed range. See specifications for model ranges. Reconnect the power.

## APPLICATION

The CS-652 series are factory calibrated to operate within  $\pm 2\%$  of FSO. If field calibration is required or a custom measurement range is desired, simply peel back the top label to expose the calibration pots. See Figure 3. The adjustment pots set the current zero (4 mA) and span (20 mA) of the device and may be adjusted by about  $\pm 20\%$  of FSO. Repeat each adjustment until both are acceptable.

For applications with load currents exceeding the sensor current ranges use an external CT to reduce the current to an acceptable value. For example, to measure a 500 Amp load current, use a 500A:5A CT and wrap the CT secondary through the CS-652-R1 two times on the 10 Amp range so the sensor output will be 4-20 mA = 0-500 Amps.

For applications with small load currents (such as less than 2 Amps), wrap the monitored conductor through the sensor aperture several times to increase the current measured by the sensor. For example, to measure 0-2 Amps with a CS-652-R1, wrap the conductor through the sensor aperture 5 times on the 10 Amp range so the sensor output will be 4-20 mA = 0-2 Amps.

For external CT or multiple wrap applications, ensure the controller is scaled accordingly to obtain correct readings.

For any application with multiple wraps, note that the CS-652 maximum current rating must be divided by the number of wraps. For example, with one wrap the maximum current is 100 Amps, with 5 wraps the maximum current is  $100/5 = 20$  Amps. Ensure the load current is  $< 20$  Amps or the device may overheat and be damaged.

Note these may not be practical applications, select the correct device for the current range required.

## SPECIFICATIONS

Measurement Range.....	<b>CS-652-R1:</b> 0-10/20/50 Amps <b>CS-652-R2:</b> 0-50/100/150 Amps <b>CS-652-200:</b> 0-200 Amps
Maximum Input Current.....	<b>CS-652-R1:</b> 100 Amps Continuous <b>CS-652-R2:</b> 150 Amps Continuous <b>CS-652-200:</b> 250 Amps Continuous
Accuracy.....	<b>CS-652-R1/R2:</b> $\pm 2\%$ FSO (5 to 100% of range) <b>CS-652-100/200:</b> $\pm 1\%$ FSO (5 to 100% of range)
Signal Output.....	4-20 mA
Sensor Power.....	15 to 30 Vdc (loop-powered)
Insulation Class.....	600 Vac, insulated conductors
Frequency.....	50/60 Hz
Response Time.....	250 mS typical, 0 to 90%
Output Load.....	250 $\Omega$ typical
Maximum Load.....	$> 600 \Omega @ 24 \text{ Vdc}$
Operating Temperature.....	-15 to 60°C (5 to 140°F)
Operating Humidity.....	5 to 90 %RH non-condensing
Terminal Block.....	14 to 22 AWG
Dimensions.....	67 x 68.6 x 24.1 mm (2.65 x 2.7 x 0.95 in)
Sensor Aperture.....	20.3 mm (0.8 in)
Enclosure Material.....	ABS/PC, UL94 V-0
Agency Approvals.....	cULus Listed
Country of Origin.....	Canada

Figure 5

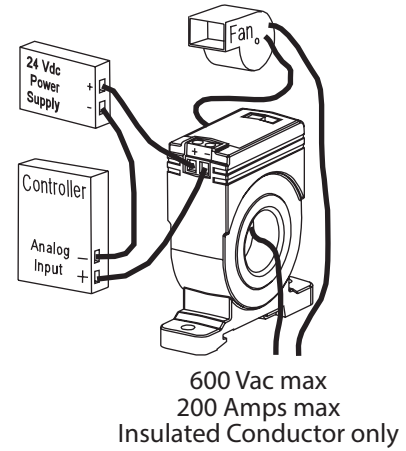
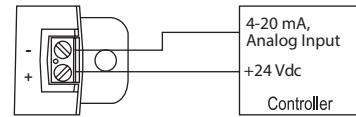
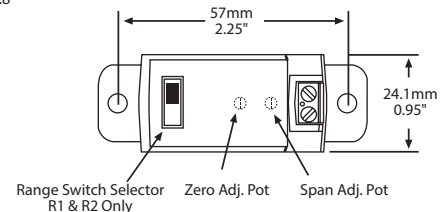
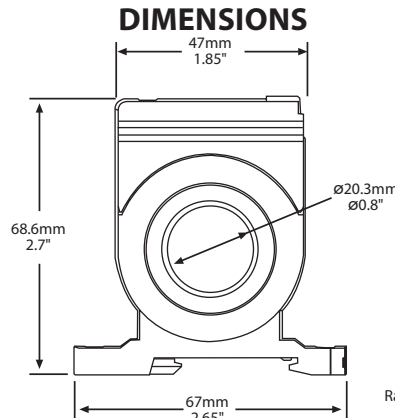
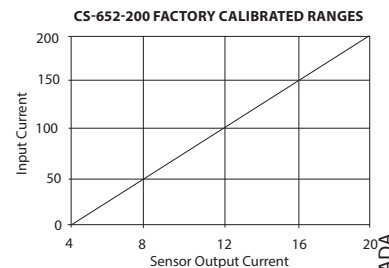
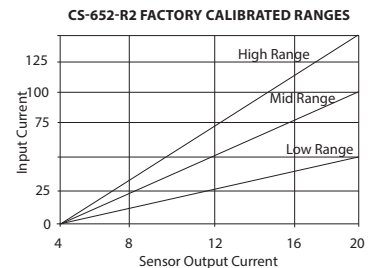
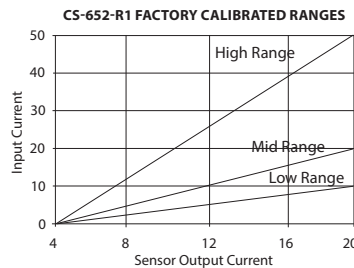
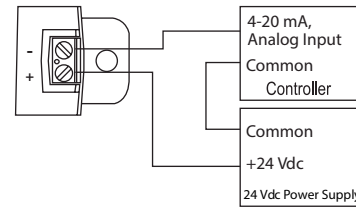

Figure 6

Wiring for 4-20 mA loop-powered output signal and 24 Vdc power from controller



Wiring for 4-20 mA loop-powered output signal and 24 Vdc external power supply



PRINTED IN CANADA