

INTRODUCTION

The mini current switch monitors line current for electrical loads such as pumps, conveyors, machine tools or fans and closes the output contacts when the adjustable trip point is exceeded. The status LED lights when the switch closes. It is typically used to monitor motor operation and can be used to determine on/off status, proof of operation, motor failure or belt loss.

The switch requires no external power and it is totally powered by induction from the AC line being monitored. The trip setpoint is factory set to the minimum value (0.75 Amps) but can be set up to 75 Amps by rotating the multi-turn adjustment pot counter-clockwise.

WARNING

- **Electric shock hazard, use caution**
- Disconnect and lock out power before installation
- Follow national and local electrical codes
- Read and understand these instructions before installing
- Installation only by qualified electrical personnel
- Do not rely on this device to indicate line power
- Only install this device on insulated conductors
- Only install on 600 Vac maximum conductors
- Do not use this device for life-safety applications
- Do not install in hazardous or classified locations
- Install this product in a suitable electrical enclosure
- **Failure to follow these instructions will result in death or serious injury**

INSTALLATION

Read all warnings before beginning installation of this device. Ensure the selected device has the correct ratings for your application. **Disconnect and lock out power.** Mount the switch with two screws through the base as seen in Figure 1.

Place the monitored conductor through the sensor hole and wire the output to the controller following the wiring illustrations in Figure 3 (not polarity sensitive).

Reconnect the power, and calibrate the switch using the calibration instructions on page 2, with the motor running normally.

MOTOR CURRENT WITH TRIP POINT SET TO DETECT A BROKEN BELT

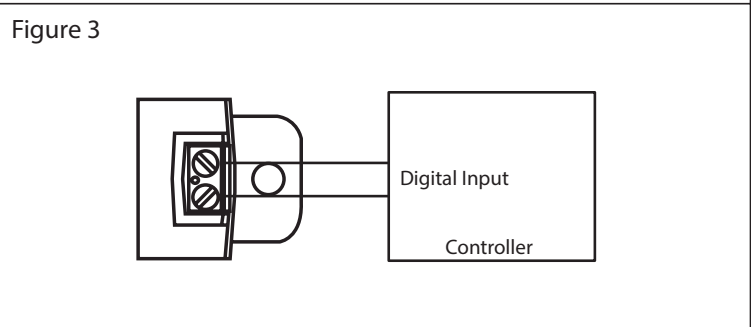
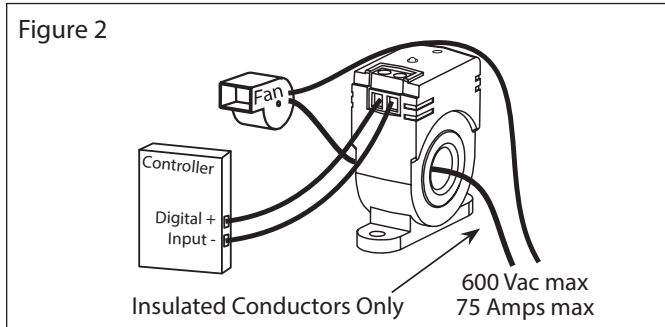
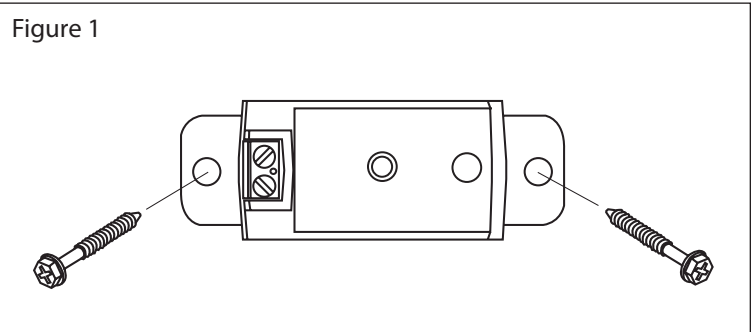
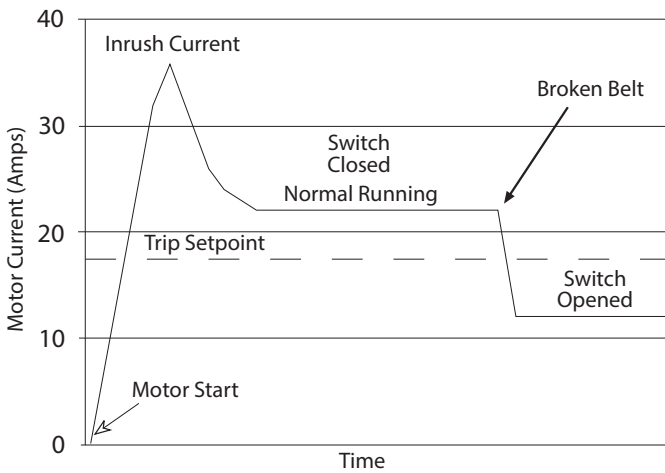

CALIBRATION

With the sensor installed, turn on the monitored load (motor, heater, etc.) and allow it to run normally. Since the CS is factory set to switch at 0.75 Amps the status LED should be lit and the contacts should be closed if the load draws more than 0.75 Amps. Rotate the multi-turn setpoint pot counter-clockwise until the status LED turns off. Then slowly turn the pot clockwise until the LED just comes on. Turn clockwise slightly more to eliminate false switching. The CS is now set to detect an under-current condition. A voltmeter can be used across the contacts to verify switch operation.

APPLICATION

For applications with load currents exceeding the sensor current range use an external CT to reduce the current to an acceptable value. For example, to monitor a 200 Amp load current, use a 200A:5A CT and wrap the CT secondary through the CS-610-75 four times so the sensor actually only sees 20 Amps when the load current is 200 Amps.

For applications with very small load currents (such as less than 1 Amp), wrap the monitored conductor through the sensor aperture several times to increase the current measured by the sensor. For example, to monitor a 0-1 Amp load with a CS-610-75, wrap the conductor through the sensor aperture 5 times so the sensor actually sees 0-5 Amps.

For any application with multiple wraps, note that the CS-610-75 maximum current rating must be divided by the number of wraps. For example, with one wrap the maximum current is 75 Amps, with 5 wraps the maximum current is $75/5 = 15$ Amps. Ensure the load current is < 15 Amps or the device may overheat and be damaged.

SPECIFICATIONS

Setpoint Range.....	0.75 to 75 Amps adjustable
Maximum Input Current.....	75 Amps continuous
Sensor Power.....	Self-powered
Output Type.....	Solid-state mosfet
Output Switch Action.....	Normally open
Output Switch Ratings.....	30 Vac/dc, 500 mA max
Indication.....	Status LED
Von at Vdc at 500 mA.....	<50 mV
Frequency.....	50/60 Hz
Response Time.....	200 mS typical
Insulation.....	600 Vac, insulated conductors
Operating Temperature.....	-15 to 60°C (5 to 140°F)
Operating Humidity.....	5 to 90 %RH non-condensing
Terminal Block.....	14 to 22 AWG
Dimensions.....	48mm W x 49mm H x 21mm D (1.9" x 1.93" x 0.83")
Sensor Aperture.....	11.4mm (0.45")
Enclosure Material.....	ABS/PC, UL94 V-0
Agency Approvals.....	cULus Listed
Country of Origin.....	Canada

DIMENSIONS

