

### INTRODUCTION

The CO Transmitter uses an electrochemical sensor to monitor the carbon monoxide level and outputs a field-selectable 4-20 mA or voltage signal. The voltage signal may also be set to 0-5 or 0-10 Vdc. The sensing range and output may be scaled to either 100, 150, 300, 400 or 500 ppm via the on-board menu. A front panel LCD is standard to ensure easy setup and operation.

Other standard features include a back light for the LCD, a front panel test switch, status indication and an alarm buzzer. The test function may also be controlled remotely with a digital

input signal. A three-key menu is implemented to allow local configuration of all device parameters.

### BEFORE INSTALLATION

Read these instructions carefully before installing and commissioning the CO Transmitter. Failure to follow these instructions may result in product damage. Do not use in an explosive or hazardous environment, with combustible or flammable gases, as a safety or emergency stop device or in any other application where failure of the product could result in personal injury. **Take electrostatic discharge precautions during installation and do not exceed the device ratings.**

### MOUNTING

The CO duct type sensor installs on the outside of a return air duct with the sampling tube inserted into the duct. Use the included foam plug to prevent air from entering the enclosure through the conduit and causing an incorrect reading. Mount the sensor in an easily accessible location in a straight section of duct at least five feet from corners and other items that may cause disturbances in the air flow. Avoid areas with vibrations or rapid temperature changes.

The duct CO detector principal of operation is based on the Venturi effect of the probe that extends into the HVAC duct. Air flowing through the duct is forced into the vent holes on one side of the probe, into the enclosure, over the CO sensor and then is drawn back out of the enclosure via the probe vent holes on the opposite side.

Drill or punch a 1-1/8" or 1-1/4" hole in the duct at the preferred location and insert the probe into the hole to mark the enclosure mounting holes. Remove the unit and drill the four mounting holes. Clean all drilled holes of debris before mounting the device. Mount the enclosure to the duct with four sheet metal screws such that the duct air flow is parallel with the vent holes in the probe (i.e.: air flows directly into the probe holes). To prevent air leaks, ensure the gasket is compressed around the probe between the device enclosure and the air duct.

Open the cover by releasing the latch and connect the device according to the wiring instructions. After wiring and setup are complete, close and latch the cover. Secure it with two self-tapping screws in the holes provided.

### HARDWARE SETUP

The only hardware setup required is to select the analog output type with the PCB switch labeled VOLT and mA. Slide the switch to the correct position for the required output signal type, either 4-20 mA or 0-5/10 Vdc.

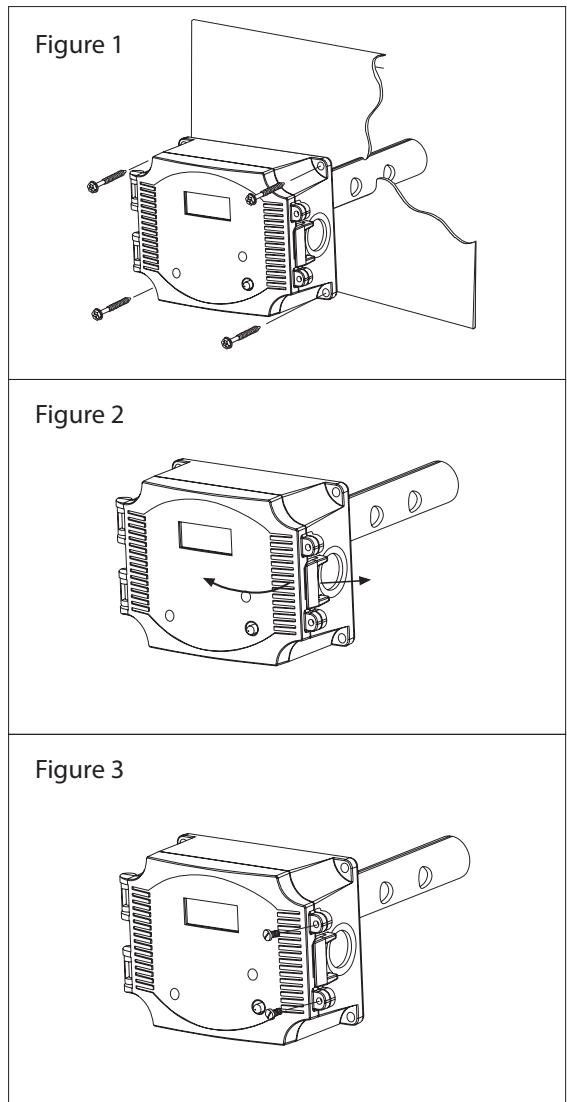

# POWER AND ANALOG OUTPUT WIRING

Use 22 AWG shielded wire for all connections and do not locate the device wires in the same conduit with wiring used to supply inductive loads such as motors. Disconnect the power supply before making any connections to prevent electrical shock or equipment damage. Make all connections in accordance with national and local codes.

The wiring configuration depends on the specific model and the installed options. Follow the example wiring diagrams to determine the correct wiring. All models have the same terminal functions. This device has a half-wave type power supply so the power supply common is the same as the output signal common. Therefore, several devices may be connected to one power supply and the output signals all share the same signal common. Use caution when grounding the secondary of an AC transformer or when wiring multiple devices so that the circuit ground point is the same on all devices and the controller.

This is a 3-wire sourcing device. All models require a 24 Vac/dc power supply to operate. Connect the positive dc voltage or the hot side of the ac voltage to the ANALOG - PWR terminal and the power supply common to the ANALOG - COM terminal. Note that the Analog COM terminal is NOT connected to the Relay COM terminals. The device is reverse voltage protected and will not operate if the power supply is connected backwards.

The linear output signal (either 4-20 mA or 0-5/10 Vdc) is available on the ANALOG - CO terminal. The signal is referenced to the Analog COM terminal. The 4-20 mA output signal operates in the Active mode and does not require a loop power supply. This means the signal current is generated by the transmitter and must not be connected to a powered input or device damage will result. This is the typical operating mode of a "three-wire device". Ensure the controller Analog Input (AI) matches the CO Transmitter output signal type before power is applied. The current signal has a maximum load that it will drive and the voltage output has a minimum load. Follow the ratings in the Specification section or inaccurate readings may result. The power must be disconnected to change from VOLT to mA. The analog output CO signal is typically connected directly to the Building Automation System (BAS) and used as a control parameter or for logging purposes.

# REMOTE TEST WIRING

The CO Transmitter has a Test function that will test the analog output and the alarm relays which is initiated by pressing the front panel TEST switch. The Test function may also be initiated remotely by shorting the TEST + and TEST - terminals. Note that the TEST - terminal is connected to the Analog COM terminal. The TEST terminals should only be connected to a dry-contact digital output from the controller that is either shorted or floating open. Ensure no power is applied to the TEST terminals. The TEST terminals may also be connected to a remote switch. If desired, only one wire need be connected to the TEST + terminal and use the power supply COM as the return signal path.

# ALARM RELAY WIRING

If equipped, the alarm relay outputs are available on the NO, COM and NC terminals for each relay. The relay COM terminals are NOT connected to the signal or power supply COM terminal nor to each other. The two relays are completely isolated and have both Normally Open (NO) and Normally Closed (NC) contacts. These signals can be used to directly control alarms, ventilation fans or may be connected to digital inputs of the BAS for status monitoring. Ensure any loads connected to the relays are within the relay ratings in the Specification section.

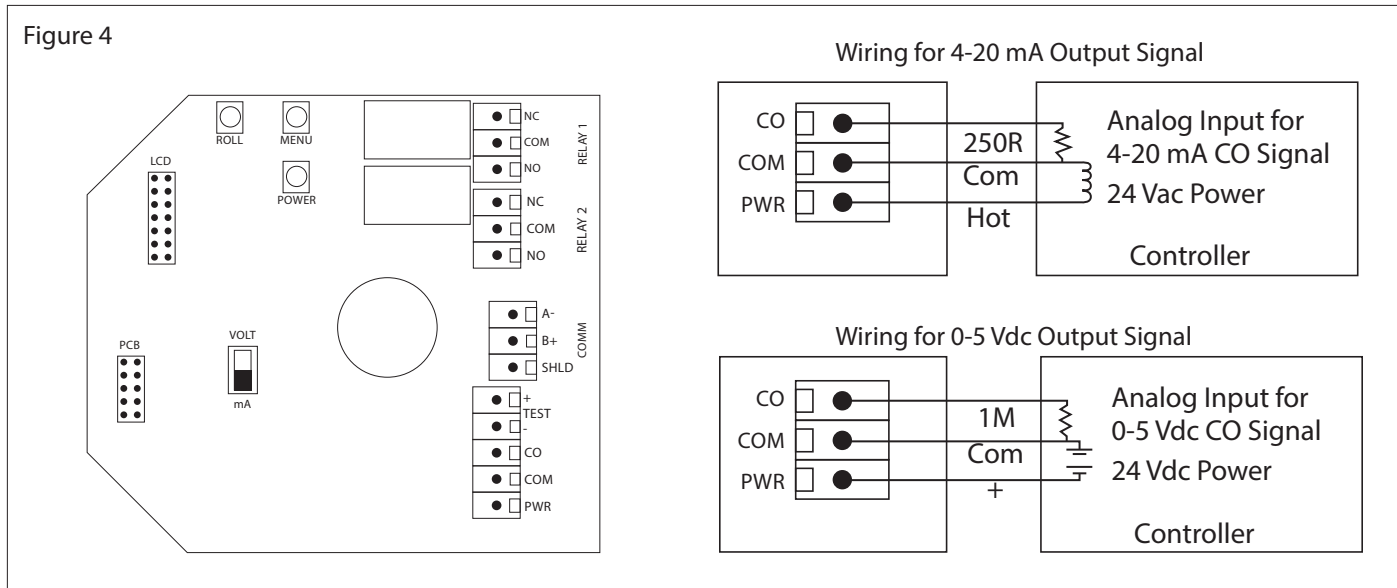

## **OPERATION - START UP**

The device will initially start up in warm-up mode which lasts for about two minutes. Immediately after applying power the LCD will display the software version number and begin a two minute countdown.

During the warm-up mode the alarm relays will be set to off, the LED will flash red, all communications are disabled, the key pad is disabled and the analog output will be set to it's minimum value.

## **OPERATION - NORMAL MODE**

In normal operation the sensor will measure the CO level in the duct air and output a proportional value on the analog output which is scaled to the default range of 0-300 ppm. The CO reading will also be displayed on the LCD and updated in the communication value. If alarm relays are installed, the present CO reading is compared to the setpoints and appropriate action is taken if an alarm condition exists. The status LED on the front cover will be green to indicate normal operation.

## **OPERATION - ALARM MODE**

The CO reading is compared to pre-set setpoints for alarms and if they are exceeded the device enters Alarm mode. The alarm reset back to Normal mode can be configured via the menu as either Automatic Reset or Manual Reset.

### **Automatic Alarm Reset (Default)**

Two optional relays are used to indicate alarm conditions. The trip point, hysteresis and delay time of each relay can be programmed via the menu. For example, Relay 1 defaults to a 50 ppm trip point, 10 ppm hysteresis and 2 minute delay time. Relay 2 defaults to a 150 ppm trip point, 20 ppm hysteresis and 2 minute delay time. All of these values can be changed via the menu. In the example for Relay 1, a timer is started when the CO level exceeds 50 ppm (the trip level). If the level drops below 50 ppm before 2 minutes (the delay time) has expired then the relay is not activated. If the CO level exceeds 50 ppm for 2 minutes then the relay is activated. The relay will remain activated until the CO level drops below 40 ppm (trip level – hysteresis). This relay can be used to signal a "low alarm". Relay 2 operates in the same manner and has independently programmable trip point, hysteresis and delay time. This relay can be used to signal a "high alarm". The LCD will indicate the Alarm mode details and the LED will flash red.

### **Manual Alarm Reset**

In this case, the alarm relays will activate the same way as described above but will not automatically reset to Normal Mode when the CO level drops below the trip level - hysteresis value. In order to reset the relay alarms to Normal Mode the user must also press the TEST switch on the front cover (or activate the remote TEST input). If the CO level is below the alarm level AND the TEST switch is pressed, then the relay alarms will return to the Normal Mode.

The Manual Reset also applies to the buzzer alarm. If the buzzer alarm is active, pressing the TEST switch will "silence" the buzzer. If the buzzer alarm was active but the CO level has been reduced below the trip point, then the TEST switch must be pressed to reset the buzzer alarm to the Normal Mode.

## **OPERATION - TEST MODE**

The Test mode function is disabled by default, it must be enabled via the menu to operate. To initiate the Test function during normal operation, either press and hold the TEST switch for 1 second or activate it remotely by shorting the TEST + to TEST – (COM). This will cause the Status LED to blink red, the analog output to go to 100% and both relays to activate. The buzzer will also beep once every 15 seconds if enabled and the LCD will indicate the Test mode and the remaining time. The Test function will continue for 5 minutes (default) and then the device will reset to normal operation. The Test function can be cancelled by pressing the TEST switch a second time. Test mode cannot be activated if the device is in Fault, Alarm or Re-Cal modes of operation, only in Normal mode. The Test function is useful to verify the output and alarm relay operation and the Test time can be programmed via the menu.

## **OPERATION - FAULT MODE**

The Fault mode function is disabled by default, it must be enabled via the menu to operate. The Fault function will monitor the CO sensor lifetime and indicate when the CO sensor should be replaced. If the device determines that the sensor has reached the end of it's useful life and that replacement is necessary it will enter Fault mode. This will cause the Status LED to blink red and the buzzer to beep once every 10 minutes. The LCD will periodically show "Sensor Fault". The Fault mode can be disabled via the menu or enabled at any time. If enabled, and the device is in Fault mode, pressing the TEST switch will "silence" the buzzer due to the Fault alarm only. Buzzer silence due to the Fault alarm will hold until the Fault condition is reset via the menu. The buzzer may still activate due to a CO setpoint alarm if enabled.

## OPERATION - RE-CAL MODE

The Re-Cal mode function is enabled by default, it must be disabled via the menu if it is not required. The Re-Cal function will monitor the device and indicate when the CO sensor should be re-calibrated. If the device determines that the sensor requires re-calibration it will enter Re-Cal mode. This will cause the Status LED to blink red and the buzzer to beep once every 10 minutes. The LCD will periodically show "ReCal Required". If enabled, and the device is in Re-Cal mode, pressing the TEST switch will "silence" the buzzer due to the ReCal alarm only. Buzzer silence due to the ReCal alarm will hold until the ReCal condition is reset via the menu. The buzzer may still activate due to a CO setpoint alarm if enabled.

## OPERATION - USER MENU

The device has several parameters that can be configured locally via the User menu using the keypad and LCD. All parameters default to typical values but the installer may want to change some values. In some cases, such as the device network address, the installer MUST change the settings before operation. Any changes made are saved in non-volatile memory and are restored in case of a power loss. Only the menu items relevant to the device model will be shown. The menu can be accessed at any time after the warm-up mode and if there is 5 minutes of inactivity the menu will close and normal operation will continue. Note that the TEST switch has no affect when the User menu is in use.

The menu has several items as shown below. To enter the menu, press and release the <MENU> key. This will enter the User menu step 1, pressing the <MENU> key a second time advances to step 2. Each press of the <MENU> key advances the menu item. No values are saved or changed by using the <MENU> key. The <ROLL> key is used to make changes to program variables by scrolling through the available options. Holding the <ROLL> key pressed will scroll through some options at a faster rate. When a value is changed, use the <SAVE> key to save it to memory and advance to the next menu item. The default values are shown in each step below.

<MENU> Press to enter the User Menu

### 1. CARBON MONOXIDE RANGE

CO Range  
0-300ppm

Press the <ROLL> key to scroll through the available options. The CO sensing range and output scale can be changed to 0-100ppm, 0-150ppm, 0-300ppm, 0-400ppm, or 0-500ppm Press the <SAVE> key to save any change.

<MENU> Press to advance to next menu item

### 2. BUZZER ALARM

Buzzer  
Enable

Use the <ROLL> key to enable or disable the buzzer alarm. When disabled, the buzzer will not sound if the buzzer trip point is exceeded. The buzzer will still beep on startup and will still beep for a fault alarm (if enabled) and ReCal alarm (if enabled). Press <SAVE> key to save the setting.

<MENU> Press to advance to next menu item

Only if **Buzzer** enabled

### 3. BUZZER TRIP

Buzzer  
Trip 150

Use the <ROLL> key to scroll through the available options. The buzzer alarm trip point may be set from 20 to 500 ppm in 10 ppm increments. Press the <SAVE> key to save the setting.

<MENU> Press to advance to next menu item

### 4. BUZZER DELAY

Buzzer  
Del 5Min

Use the <ROLL> key to scroll through the available options. The buzzer delay may be set from 0 to 10 minutes in 1 minute increments. Press <SAVE> to save the setting. The factory default is 5 minutes.

<MENU> Press to advance to next menu item

### 5. BUZZER TEST

Buzzer  
Test OFF

Use the <ROLL> key to toggle the buzzer ON or OFF.

<MENU> Press to advance to next menu item

Only if **Relay 1** installed

**6. ALARM TRIP POINT**

*Relay 1  
Trip 50*

Use the <ROLL> key to scroll through the available options. The relay 1 alarm trip point may be set from 20 to 500 ppm in 10 ppm increments. Press <SAVE> to save the setting.

<MENU>

Press to advance to next menu item

**7. HYSTERESIS**

*Relay 1  
Hyst 10*

Use the <ROLL> key to scroll through the available options. The relay 1 hysteresis may be set from 10 to 100 ppm in 5 ppm increments. Press <SAVE> to save the setting. Note that the maximum value may be limited by the trip point value.

<MENU>

Press to advance to next menu item

**8. DELAY**

*Relay 1  
Del 2Min*

Use the <ROLL> key to scroll through the available options. The relay 1 delay may be set from 0 to 10 minutes in 1 minute increments. Press <SAVE> to save the setting.

<MENU>

Press to advance to next menu item

**9. DIRECT**

*Relay 1  
Direct*

Use the <ROLL> key to toggle the available options. Relay 1 operation may be set to Direct or Reverse. Direct operation means the relay is normally not energized and will energize on an alarm condition (the NO/NC PCB destinations are correct). Reverse operation means the relay is normally energized and will de-energize on an alarm condition (the NO/NC PCB designations are reversed). Reverse operation can be used for "Fail Safe" operation as the relay will change state on power loss. Press <SAVE> to save the setting.

<MENU>

Press to advance to next menu item

**10. TEST**

*Relay 1  
Test OFF*

Use the <ROLL> key to toggle relay 1 ON or OFF.

<MENU>

Press to advance to next menu item

Only if **Relay 2** installed

**11. ALARM TRIP POINT**

*Relay 2  
Trip 150*

Use the <ROLL> key to scroll through the available options. The relay 2 alarm trip point may be set from 20 to 500 ppm in 10 ppm increments. Press <SAVE> to save the setting.

<MENU>

Press to advance to next menu item

**12. HYSTERESIS**

*Relay 2  
Hyst 20*

Use the <ROLL> key to scroll through the available options. The relay 2 hysteresis may be set from 10 to 100 ppm in 5 ppm increments. Press <SAVE> to save the setting. Note that the maximum value may be limited by the trip point value.

<MENU>

Press to advance to next menu item

**13. DELAY**

*Relay 2  
Del 2Min*

Use the <ROLL> key to scroll through the available options. The relay 2 delay may be set from 0 to 10 minutes in 1 minute increments. Press <SAVE> to save the setting.

<MENU>

Press to advance to next menu item

Only if **Relay 2** installed

## 14. DIRECT

*Relay 2  
Direct*

Use the <ROLL> key to toggle the available options. Relay 2 operation may be set to Direct or Reverse. Direct operation means the relay is normally not energized and will energize on an alarm condition (the NO/NC PCB designations are correct). Reverse operation means the relay is normally energized and will de-energize on an alarm condition (the NO/NC PCB designations are reverse). Reverse operation can be used for "Fail Safe" operation as the relay will change state on power loss. Press <SAVE> to save the setting.

<MENU>

Press to advance to next menu item

## 15. TEST

*Relay 2  
Test OFF*

Use the <ROLL> key to toggle relay 2 ON or OFF.

<MENU>

Press to advance to next menu item

## 16. TEST MODE

*TestMode  
Disable*

Use the <ROLL> key to enable or disable the Test mode. When disabled, the TEST switch or TEST input will not initiate the test function. When enabled, the TEST switch will initiate the test function. Note that the test mode will only function if the device is operating in the Normal mode, the test function cannot be initiated if any alarm is present. Press <SAVE> to save the setting.

<MENU>

Press to advance to next menu item

Only if **Test Mode** enabled

## 17. OPERATING TIME

*TestMode  
Time 5*

Use the <ROLL> key to scroll through the available options. The test mode operating time may be set from 1 to 15 minutes in 1 minute increments. Press <SAVE> to save the setting. This item sets how long the test mode will operate when the TEST switch is pressed.

<MENU>

Press to advance to next menu item

## 18. FAULT ALARM

*Fault Md  
Disable*

Use the <ROLL> key to enable, disable, or reset. When disabled, the device will not sound the buzzer or provide LCD and status LED indication when the sensor life is exceeded. When enabled, the fault alarm will activate to indicate the sensor life is exceeded. Press <SAVE> to save the setting. If it is set to reset and <SAVE> is pressed, then the fault condition is cleared, the life-time timer is reset and fault mode is set back to it's default of disable. It may be enabled again.

<MENU>

Press to advance to next menu item

Only if **Fault Mode** enabled

## 19. FAULT MODE TIMER

*Fault Md  
Time 3yr*

Use the <ROLL> key to set the fault mode timer to 3, 4, 5 or 6 years. Press <SAVE> to save the setting. If a desired time has already been exceeded, then it cannot be selected.

## 20. RECAL MODE

*ReCal Md  
Enable*

Use the <ROLL> key to select enable, disable or reset. When disabled, the device will not sound the buzzer or provide LCD and status LED indication when the sensor requires re-calibration. When enabled, the ReCal alarm will activate to indicate the sensor requires re-calibration. Press <SAVE> to save the setting. If it is set to reset and <SAVE> is pressed, the ReCal condition is cleared, the ReCal timer is reset and ReCal mode is set back to it's default of enable. This can be used if the CO sensor is required to be re-calibrated at known intervals.

<MENU>

Press to advance to next menu item

## 21. RECAL TIMER

*ReCal Md  
Time 1yr*

Use the <ROLL> key to set the ReCal mode timer to 1, 2 or 3 years. Press <SAVE> to save the setting. This is used to set the CO sensor re-calibration interval.

<MENU> Press to advance to next menu item

## 22. ALARM MODE

*Alarm Md  
Auto*

Use the <ROLL> key to set the alarm mode to auto or manual. The setting controls how the relay alarms and the buzzer alarm resets back to normal mode. For the auto setting, the device will reset the alarms automatically once the CO level drops below the set alarm thresholds. For the manual setting, the CO level must be below the alarm thresholds AND the user must press the TEST switch on the device to reset the alarms. Press <SAVE> to save the setting.

<MENU> Press to advance to next menu item

## 23. ZERO FILTER

*0 Filter  
Enable*

Use the <ROLL> key to enable or disable the zero filter. When enabled, the device will filter low ppm readings such that 0-5 ppm CO will display and output 0 ppm. When disabled, 0-5 ppm will display and output actual 0-5 ppm. Press <SAVE> to save the setting. Note that this should be set to disable when doing a ZERO gas calibration.

<MENU> Press to advance to next menu item

## 24. DISPLAY

*Display  
CO Value*

Use the <ROLL> key to toggle the setting to either CO Value or Status. When set to CO value, the actual ppm value of the CO reading will be displayed on the LCD. When set to Status, the ppm value will not be displayed only the device operating status. Press <SAVE> to save the setting.

<MENU> Press to advance to next menu item

## 25. BACKLIGHT

*BackLite  
Enable*

Use the <ROLL> key to enable or disable the LCD backlight. When enabled the backlight is always on and when disabled it never lights. Press <SAVE> to save the setting.

<MENU> Press to advance to next menu item

## 26. OUTPUT TYPE

*Out Type  
0-5 Vdc*

Use the <ROLL> key to toggle the voltage output type to either 0-5 Vdc or 0-10 Vdc. Press <SAVE> to save the setting. Note that this item is only shown if the PCB switch is in the VOLT position. Also note that the output type can only be changed by disconnecting the power to the unit.

<MENU> Press to advance to next menu item

## 27. OUTPUT TEST

*Output  
Test OFF*

Use the <ROLL> key to scroll through the available options. The output and display depends on the output type configuration. For 4-20 mA output the settings are OFF, 4, 8, 12, 16, 20 mA, for 0-5 Vdc output they are OFF, 0, 1, 2, 3, 4, 5, Vdc and for 0-10 Vdc output they are OFF, 2, 4, 6, 8, 10 Vdc. This can be used to test the output signal.

<MENU> Press to advance to next menu item

## 28. EXIT

Menu  
Exit

Press <SAVE> to exit the menu and return to normal operation or <MENU> to repeat the menu.

## CALIBRATION

The CO transmitter features a cover mounted sensor PCB that is pre-calibrated. This means that the entire sensor PCB can simply be replaced with a new calibrated PCB if desired without having to remove the enclosure and the main processor board. This sensor swap can be completed in seconds. Simply unplug the device ribbon cable connection, remove the old sensor PCB, install the new PCB and reconnect the ribbon cable. There is no need to make any adjustments or apply gas to the transmitter using the sensor swap method. **In this case, the Fault Mode should be reset if it is enabled.**

Figure 5

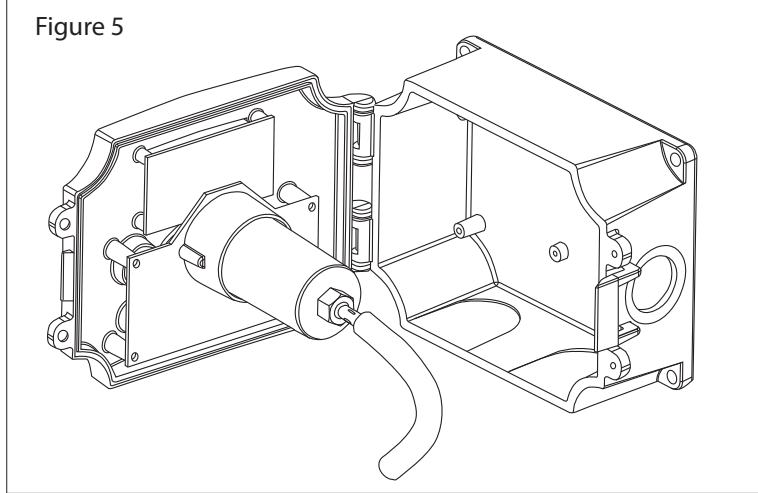

The device may also be calibrated or verified with the CO gas if required. This requires a field calibration kit consisting of a bottle of gas (250 ppm CO in air for example), a tank pressure regulator with flow restrictor and the necessary tubing with a calibration cap to cover to the sensor. Calibration can be done at 20 to 27°C.

Verification with gas can be done without removing the device cover. Simply apply gas using the calibration cap attached directly to the port on the cover and monitor the output signal or LCD.

The device cover must be opened to perform an actual calibration. In the case, the gas calibration cap attached to the sensor fixture on the cover as before. The sensor must be continuously powered for at least 1/2 hour prior to calibration. Calibrate the sensor first in clean air with no CO gas present. Simply adjust the ZERO pot on the sensor board until 4 mA (or 0 Vdc) output is obtained and the LCD displays 0 ppm. Note that the "0 Filter" menu item should be disabled to set the 0 ppm. The ZERO and SPAN pots are located on the edge of the cover sensor PCB and are clearly marked on the PCB.

Then attach the gas supply. Turn the regulator on/off knob fully off and attach it to the 250 ppm gas bottle and firmly tighten it by hand. Moisten the sponge and squeeze out any excess water. Place the sponge in the cap so that it will not touch the sensor but does not plug the hole in the side of the cap. Attach the cap to the fixture over the sensor. If the gas cap is too loose on the fixtures, simply place a wrap of electrical tape around the cap the tighten. Slowly turn the valve knob on the regulator to let the gas begin flowing.

The regulator will restrict the flow rate to the specified 200 ml/min and the sponge will ensure the gas is in the right humidity range. Wait for 5 minutes and then adjust the SPAN pot on the sensor board until the output and LCD reads 250 ppm. Close the valve on the tank and take a cap off from the sensor. **Calibration is complete. In this case, the ReCal Mode should be reset if it is enabled.**

## DIMENSIONS

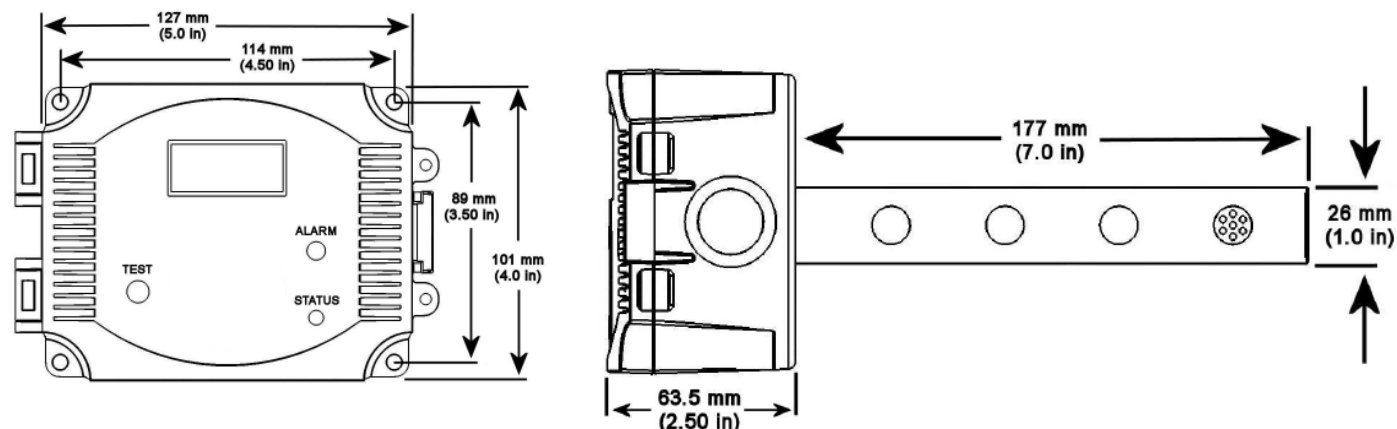

# SPECIFICATIONS

## POWER SUPPLY

Power Supply .....24 Vdc  $\pm$ 20% or 24 Vac  $\pm$ 10% (non-isolated half-wave rectified)  
Consumption .....100 mA max (with all options on)  
Protection Circuitry.....Reverse voltage protected, output limited and transient protected  
Output Signal .....4-20 mA active, 0-5 or 0-10 Vdc (selectable)  
Output Drive Capability ...**Current:** 450  $\Omega$  max  
**Voltage:** 10K  $\Omega$  min

## ENCLOSURE

LCD Display .....1 ppm resolution, 35mm W x 15mm H, alpha-numeric  
(1.4" x 0.6") with backlight  
Status LED .....Two color (red/green) on front panel  
Test Switch .....Performs I/O tests, front panel and remote connection  
Dimensions .....127mm W x 101mm H x 65mm D (5" x 4" x 2.55")  
Agency Approvals .....Sensor is UL recognized for ANSI/UL-2034 and UL-2075, E240671

## BUZZER

Alarm .....85db @ 10 cm  
Trip Point .....Programmable 20 to 500 ppm in 10 ppm increments  
Delay .....Programmable 0 to 10 minutes in 1 minute increments

## OPTIONAL RELAY

Outputs .....Form C contacts (NO and NC), 5 Amps @ 250 Vac, 5 Amps @ 30 Vdc  
Relay 1 Trip Point .....Programmable 20 to 500 ppm in 10 ppm increments  
Relay 2 Trip Point .....Programmable 20 to 500 ppm in 10 ppm increments  
Relay Hysteresis .....Programmable 10 to 100 ppm in 5 ppm increments  
Relay Delay .....Programmable 0 to 10 minutes in 1 minute increments

## GENERAL

Measurement .....Electrochemical  
Sample Method .....Diffusion  
Measurement Range .....0-100, 150, 300, 400 or 500 ppm (selectable)  
Accuracy ..... $\pm$ 5 ppm or  $\pm$ 5% of reading (whichever is greater)  
0 to 50°C (32 to 122°F), 15 to 90 %RH  
Operating Conditions .....-20 to 50°C (-4 to 122°F), 15 to 90 %RH, 0.9 to 1.1 atm  
Stability .....<5% signal loss/year  
Response Time .....<60 seconds for 90% step change  
Enclosure .....127 mm W x 101 mm H x 65 mm D (5.0" x 4.0" x 2.55")  
Duct Probe .....177 mm (7") long x 25.4 mm (1") diameter  
Wiring Connections .....Screw terminal block (14 to 22 AWG)  
Country of Origin .....Canada