



### INTRODUCTION

The CO<sub>2</sub> transmitter uses Infrared Technology to monitor CO<sub>2</sub> levels and outputs a linear 4-20 mA or 0-5/0-10 Vdc signal. Options include an LCD, control relay, override switch, slide pot setpoint control and resistive temperature sensor. Features include a back-lit LCD and user menu for easy installation.

Standard features include a field selectable output signal of either 4-20 mA, 0-5 Vdc or 0-10 Vdc for the highest versatility, programmable CO<sub>2</sub> measurement span, a backlit alpha-numeric LCD and easy menu operation for configuration.

Optional features include a resistive temperature sensor output a control relay with programmable setpoint, hysteresis and time delay, and a dry-contact override switch.

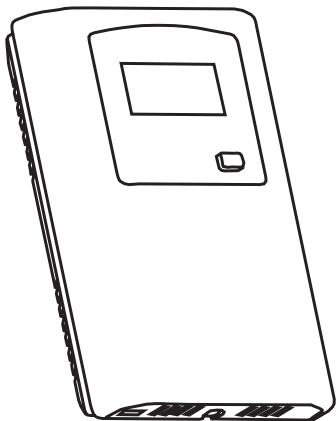

### BEFORE INSTALLATION

Read these instructions carefully before installing and commissioning the device. Failure to follow these instructions may result in product damage. Do not use in an explosive or hazardous environment, with combustible or flammable gases, as a safety or emergency stop device or in any other application where failure of the product could result in personal injury. Take electrostatic discharge precautions during installation. De-energize the power supply prior to installation, this device is intended for indoor air conditioned spaces, contact factory for other applications. **Do not exceed device ratings. This product is not intended for life-safety applications.**

### MOUNTING

The transmitter installs directly on a standard electrical box and should be mounted five feet from the floor of the area to be controlled. **Do not mount the sensor near doors, opening windows, supply air diffusers or other known disturbances. Avoid areas where the detector is exposed to vibrations or rapid temperature changes.** Prevent measurement errors by sealing the wall or conduit openings to prevent air migration from the wall cavity.

The cover is hooked to the base at the top edge and must be removed from the bottom edge first. Use a small Phillips screwdriver to loosen the security screw as shown in Figure 1. Complete removal of the screw is not required. Use the screwdriver to carefully pry each bottom corner if necessary. Tip the cover away from the base and sit it aside as shown in Figure 2.

The PCB must be removed from the base to access the mounting holes. **Follow anti-static procedures when handling the PCB and be careful not to touch the sensors.**

The PCB is removed by pressing the enclosure base to unsnap the latch near the bottom edge, then the PCB can be lifted out of the base as shown in Figure 3.

Sit the PCB aside until the base is mounted on the wall. For added protection, place the PCB in the supplied anti-static bag.

Figure 1

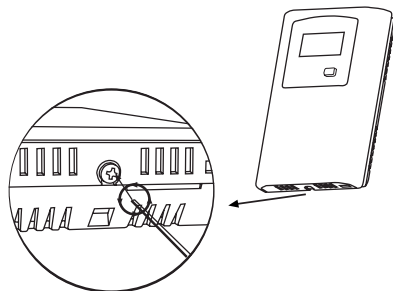

Figure 2

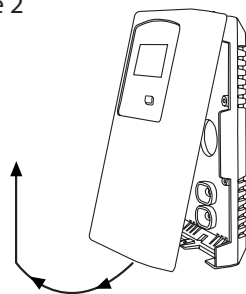

Figure 3

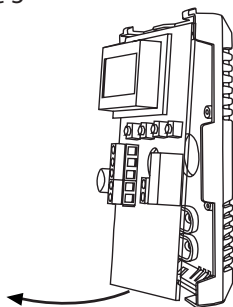
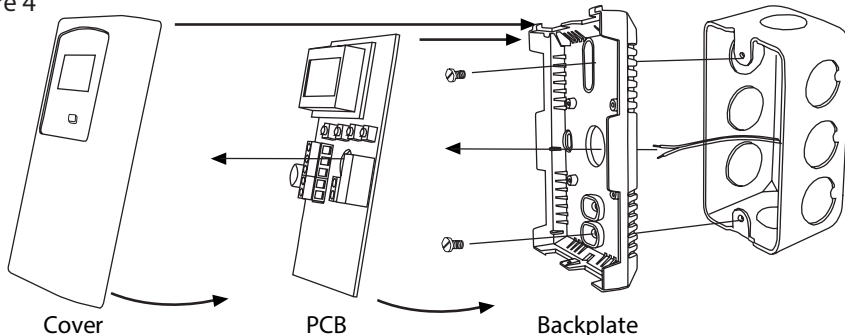

Figure 4



Mount the base by screwing to an electrical box or directly to the wall as shown in Figure 4.

After the base is screwed to an electrical box or directly to the wall using the appropriate holes, remove the PCB from the anti-static bag, feed connection wires through the center hole and place the top of the PCB into the PCB holders on the backplate and snap the bottom of the PCB into place as shown in Figure 4.

Making wiring connections as per the Wiring Illustrations below and install the decorative cover by placing the top of the cover into the cover holder on the top of the backplate and snapping the bottom into place as shown in Figure 4. Tighten the security screw with a Phillips screwdriver.

## WIRING

Deactivate the 24 Vac/dc power supply until all connections are made to the device to prevent electrical shock or equipment damage. Follow proper electrostatic discharge (ESD) handling procedures when installing the device or equipment damage may occur. Use 22 AWG shielded wiring for all connections and do not locate the device wires in the same conduit with wiring used to supply inductive loads such as motors. Make all connections in accordance with national and local codes.

This is a 3-wire sourcing device. Connect the plus dc or the ac voltage hot side to the PWR terminal. The supply common is connected to the COM terminal. The device is reverse voltage protected and will not operate if connected backwards. It has a half-wave power supply so the supply common is the same as the signal common. Several devices may be connected to one power supply and the output signals all share the same common. Use caution when grounding the secondary of a transformer or when wiring multiple devices to ensure the ground point is the same on all devices and the controller.

Figure 5

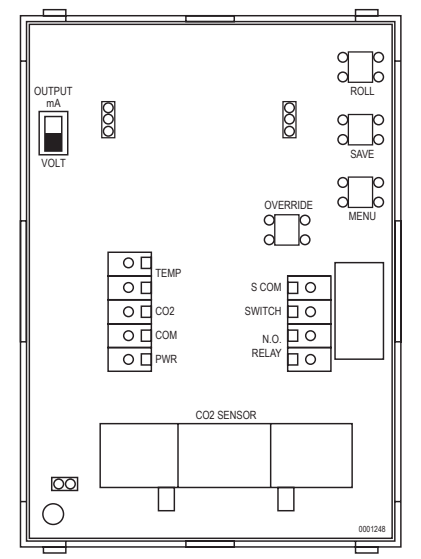

Figure 6 Wiring for voltage output signal and 24 Vdc power from controller

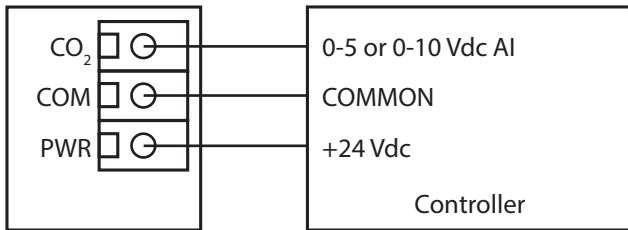

Figure 6 Wiring for all output and external 24 Vac power transformer or external 24 Vac power supply

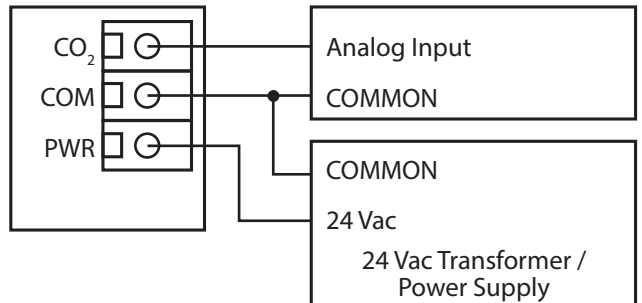

Figure 7

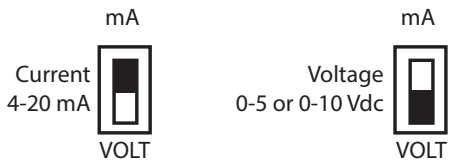
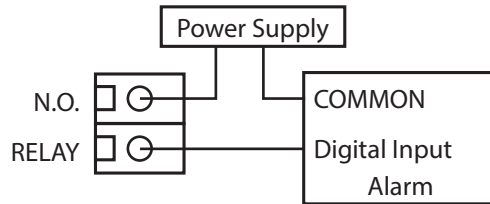

Figure 8



The analog output is available on the CO<sub>2</sub> terminal. This signal is switch selectable for either voltage or 4-20 mA active output as shown in Figure 7. In voltage mode the output is selectable for either 0-5 or 0-10 Vdc later during the menu setup (the factory default is 0-5 Vdc). The current output operates in the active mode and does not require a loop power supply (the signal current is generated by the transmitter and must not be connected to a powered input or device damage will result).

Check the controller Analog Input to determine the proper connection before applying power. Both current and voltage signals are referenced to the COM terminal. The analog output signal is typically connected directly to the Building Automation System (B.A.S.) and used as a control parameter or for logging purposes.

Figure 9

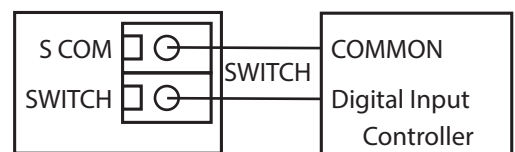
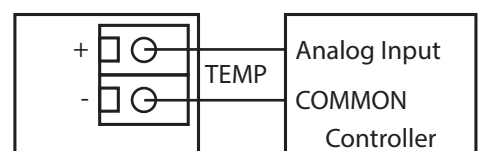

Figure 10



The optional relay output is on the N.O. RELAY terminals as shown in Figure 8. The relay output is completely isolated and has a Normally Open (NO) signal. This signal can be used to directly control an alarm or ventilation fan. See specifications for contact ratings.

The optional override switch is a two-wire dry contact normally open switch contact as shown in Figure 9.

The two-wire temperature sensor output is available with various RTDs and thermistors to suit all control applications and is available on the TEMP terminals as shown in Figure 10.

## START-UP MODE

Verify the device is properly wired and connections are tight. Ensure the V/I switch is set for the correct signal type. Apply power and the LCD will indicate the software version number, the output signal type, the relay setpoint (if installed), the CO<sub>2</sub> measurement range and then the sensor will begin reading the CO<sub>2</sub> level, output the correct analog signal and display the value on the LCD.

## OUTPUT SIGNAL

The CO<sub>2</sub> output is scaled such that 4-20 mA (or 0-5/0-10 Vdc) equals 0 to Out\_High. Depending on the model, the factory default is 0-20,000 ppm. Out\_High can be changed in the Setup Menu and the output is scaled accordingly. If using voltage output type, the default is 0-5 Vdc (0-10 can be selected in the menu).

## OPERATION

The output signal is available on the CO<sub>2</sub> terminal and is connected to the BAS analog input which reads the signal and calculates the CO<sub>2</sub> ppm value using correct scaling for the range and signal type. The CO<sub>2</sub> value is used to control output ventilation devices or initiate alarms. The CO<sub>2</sub> value is also displayed locally on the optional LCD.

If a relay is installed it can control a small fan or alarm by setting the trip value and hysteresis to appropriate values.

If a temperature sensor is installed it will be wired to an analog input of the BAS that is set for the specific resistance type. This could be a 10 KΩ thermistor, a 1000Ω RTD or other sensor values. The BAS reads the resistance signal and converts it to a temperature value.

The override switch provides a dry contact closure to a digital input of the BAS.

## SETUP MENU

The menu has several items shown below. Some items change depending on the hardware configuration and the CO<sub>2</sub> sensor. To enter the menu, press and release the <MENU> key while in normal operation. This will enter SETUP menu step 1, pressing the <MENU> key again advances to step 2. Each press of <MENU> advances the menu item. No values are saved or changed by using <MENU>. The <ROLL> key is used to make changes to program variables by scrolling through the available options. When a value is changed, use the <SAVE> key to save it to memory and advance to the next menu item as shown in Figure 11.

<MENU> Press and release the <MENU> key to enter the Setup Menu

### 1. CO<sub>2</sub> RANGE

Out High  
20000 PPM

The default CO<sub>2</sub> range is 0-20,000 ppm. The span can be changed from 2000 to 20,000 ppm in increments of 500. Use the <ROLL> key to change the value and <SAVE> to save. The factory default is 20,000 ppm.

<MENU> Press to advance to next menu item

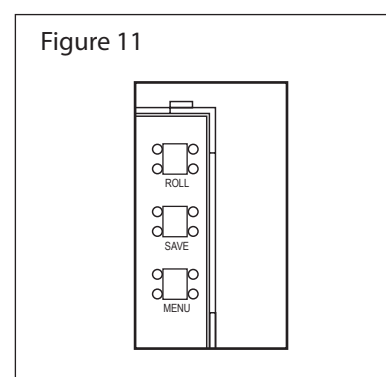

## 2. ALTITUDE CORRECTION

Altitude  
0 Ft

The default is 0 feet. Change by using the <ROLL> key from 0 to 5000 feet in 500 ft increments. Change for CO2 local altitude correction and press <SAVE> to save a change.

<MENU> Press to advance to next menu item

Only if **Relay** option Installed

## 3. RELAY SETPOINT

Relay SP  
1000 ppm

The relay trip setpoint default is 1000 ppm. It can be changed from 500 to 5000 in 100 ppm increments. Save changes by using the <SAVE> key.

<MENU> Press to advance to next menu item

## 4. RELAY HYSTERESIS

Relay Hy  
50 ppm

The relay hysteresis default is 50 ppm. This can be changed from 25 to 200 in 25 ppm increments. Use <SAVE> to save any change.

<MENU> Press to advance to next menu item

## 5. RELAY TEST

Relay  
Test OFF

Use the <ROLL> key to toggle the relay ON or OFF for testing purposes. Press either <SAVE> or <MENU> to turn the relay o and advance to the next item.

<MENU> Press to advance to next menu item

## 6. OUTPUT VOLTAGE SPAN

Out Type  
0-5 Vdc

Use the <ROLL> key to toggle the relay ON or OFF for testing purposes. Press either <SAVE> or <MENU> to turn the relay o and advance to the next item.

<MENU> Press to advance to next menu item

## 7. OUTPUT TEST

Output  
Test OFF

Use the <ROLL> key to toggle the output OFF (normal operation), MIN (minimum output) or MAX (maximum output) for testing purposes. Press either <SAVE> or <MENU> to set it back to OFF and advance to the next item.

<MENU> Press to advance to next menu item

## 8. CO<sub>2</sub> CALIBRATION

Calibrat  
0 PPM

This item is used for 0 ppm gas calibration and is explained in the Calibration section.

<MENU> Press to exit the menu and return to normal mode

## 9. CO<sub>2</sub> CALIBRATION

Calibrat  
1000 PPM

This item is used for 1000 ppm gas calibration and is explained in the Calibration section.

<MENU> Press to exit the menu and return to normal mode

## 10. CO<sub>2</sub> CALIBRATION

Calibrat  
20000 PPM

This item is used for 20,000 ppm gas calibration and is explained in the Calibration section.

<MENU> Press to exit the menu and return to normal mode

Only if **Viewable LCD** option Installed

## 11. BACKLIGHT

BackLite  
Enable

Use the <ROLL> key to enable or disable the LCD backlight. When enabled the backlight is always on, when disabled it never lights. Press the <SAVE> key to save the setting. The factory default is Enable.

<MENU> Press to exit the menu and return to normal mode

## 12. RESTORE DEFAULTS

Restore  
Defaults

Press the <SAVE> key to restore calibration to original factory settings.

<MENU> Press to advance to next menu item

## 13. MENU EXIT

Menu  
Exit

Press <SAVE> to exit the menu and return to normal operation or <MENU> to repeat the menu.

## CALIBRATION

Calibration with gas requires a field calibration kit with pressure regulator, necessary tubing and appropriate bottles of CO<sub>2</sub> gas.

The dual-channel sensor with extended range requires a 3-point calibration with 0, 1000 and 20,000 ppm gas (in order).

## 0 PPM CALIBRATION

Turn the regulator knob off and attach it to the Nitrogen gas bottle and hand tighten. Remove the cover of the unit to be calibrated to expose the gas sensor chamber. The tubing from the gas bottle can be connected to either port on the chamber after the plastic cap is removed. Gently remove one cap and connect the tubing, note that strong shock or vibration can affect calibration.

Ensure the device has been operating normally for at least five minutes before applying gas. Turn the valve knob on the regulator to start the gas flow. The regulator will restrict the flow rate to the specified 100 ml/min. After a brief period the gas will flow into the chamber. Wait 1 to 2 minutes until the CO<sub>2</sub> reading stabilizes.

Enter the Setup menu and use the <MENU> key to advance to Calibrat 0 PPM. Press and hold the <SAVE> key for 2 seconds and the display will change to Waiting Calibrat then to Waiting 5 minute to indicate that the process of setting the internal calibration is taking place.

This takes about 5 minutes while the LCD counts down. Do not disturb the unit or the gas flow. When complete the unit will display the ppm value and Cal Done. Press the <SAVE> key to return to normal operation and shut the gas off.

## 1000 PPM CALIBRATION

Connect the 1000 ppm CO<sub>2</sub> gas bottle and apply the gas as before. The CO<sub>2</sub> reading on the LCD will begin to approach 1000 ppm. Wait 1 to 2 minutes until the CO<sub>2</sub> reading stabilizes.

Enter the Setup menu and use the <MENU> key to advance to Calibrat 1000 PPM. Press and hold the <SAVE> key for 2 seconds and the display will change to Waiting Calibrat then to Waiting 5 minute to indicate that the device is calibrating. Again, this process takes about 5 minutes. When calibration is complete the unit will display the ppm and Cal Done. Press the <SAVE> key to return to normal operation and shut the gas off.

## 20,000 PPM CALIBRATION

Connect the 20,000 ppm CO<sub>2</sub> and apply the gas as before. The LCD will begin to approach 20,000 ppm. Wait 1 to 2 minutes until the CO<sub>2</sub> reading stabilizes.

Enter the Setup menu and use the <MENU> key to advance to Calibrat 20,000 PPM. Press and hold the <SAVE> key for 2 seconds and the display will change to Waiting Calibrat then to Waiting 5 minute.

Again, wait 5 minutes and when calibration is complete the unit will display the ppm and Cal Done. Press the <SAVE> key to return to normal operation and shut the gas off.

Disconnect the tubing and replace the cap on the sensor chamber as calibration is complete.

## SPECIFICATIONS

Power Supply .....	20 - 28 Vac/dc (non-isolated half-wave rectified)
Consumption .....	100 mA max @ 24 Vdc, 185 mA max @ 24 Vac (with all options)
Output Signals.....	4-20 mA active (sourcing), 0-5 Vdc or 0-10 Vdc (field selectable)
Output Drive Capability .....	<b>Current:</b> 550Ω maximum <b>Voltage:</b> 5,000Ω minimum
Protection Circuitry.....	Reverse voltage protected, over-voltage protected
Operating Conditions .....	0 to 50°C (32 to 122°F), 0 to 95 %RH non-condensing
Wiring Connections.....	Screw terminal block (14 to 22 AWG)
Sensor Coverage Area.....	100 m <sup>2</sup> (1000 ft <sup>2</sup> ) typical
Enclosure .....	Wall mount enclosure, 84mm W x 119mm H x 29mm D (3.3" x 4.7" x 1.15")
Approvals .....	CE
Country of Origin.....	Canada

## CO<sub>2</sub> SIGNAL

Measurement Type .....	Dual-Wavelength, Non-Dispersive Infrared (NDIR) diffusion sampling
Measurement Range.....	0 to 20,000 ppm, programmable span
Standard Accuracy .....	±75 ppm or 10% of reading (whichever is greater)
Temperature Dependence .....	0.2 %F.S. per °C
Stability .....	<5 %F.S. or <10% reading annual
Pressure Dependence.....	0.135% of reading per mm Hg
Altitude Correction .....	Programmable from 0 to 5000 ft via keypad
Response Time .....	<2 minutes for 90% step change
Warm-up Time .....	<2 minutes

## LCD DISPLAY

Resolution .....	1 ppm CO <sub>2</sub>
Size.....	35mm x 15mm (1.4" x 0.6") alpha-numeric 2 line x 8 character

## OPTIONAL TEMPERATURE SENSOR

Sensing Element.....	Various RTDs and thermistors available as 2-wire resistance output
----------------------	---

## CONTACT RATINGS

Contact Ratings.....	Form A contact (N.O.), 2 Amps @ 140 Vac, 2 Amps @ 30 Vdc
Relay Trip Point.....	Programmable via keypad
Relay Hysteresis.....	Programmable via keypad

## OPTIONAL MANUAL SWITCH

Type.....	Front panel, momentary pushbutton
Ratings.....	50 mA @ 12 Vdc, N.O., SPST

# DIMENSIONS

