

### GENERAL:

The AO-Box Model is 12-bit analog output modules designed for use with the Q-Controller control system. Each AO-Box module has 8x 4-20 mA output channels that provide 4-20mA signal as inputs to other host control devices.

The AO-Box and other IO-Box modules connect and communicate via a RS-485 2-wire connection to the Q-Controller. The Q-Controller supports any combination of the IO Box, the AO-Box can be up to 16 modules, allowing a total of 128 4-20mA analog signals to be output via a single Q-Controller.

All AO-Box configuration information is stored in Q-Controller and the 4-20mA calibration data is stored locally within the module, so replacement modules do not need to be configured and calibrated.

The AO-Box' high density packaging, removable terminal block and DIN rail mounting saves time and panel space. The module snaps easily onto standard top hat (T) profile DIN rail.

Module Address	Dip Switch Setting			
	J2 / A0	J3 / A1	J4 / A2	J5 / A3
0	OPEN	OPEN	OPEN	OPEN
1	CLOSED	OPEN	OPEN	OPEN
2	OPEN	CLOSED	OPEN	OPEN
3	CLOSED	CLOSED	OPEN	OPEN
4	OPEN	OPEN	CLOSED	OPEN
5	CLOSED	OPEN	CLOSED	OPEN
6	OPEN	CLOSED	CLOSED	OPEN
7	CLOSED	CLOSED	CLOSED	OPEN
8	OPEN	OPEN	OPEN	CLOSED
9	CLOSED	OPEN	OPEN	CLOSED
10	OPEN	CLOSED	OPEN	CLOSED
11	CLOSED	CLOSED	OPEN	CLOSED
12	OPEN	OFF	CLOSED	CLOSED
13	CLOSED	OFF	CLOSED	CLOSED
14	OPEN	CLOSED	CLOSED	CLOSED
15	CLOSED	CLOSED	CLOSED	CLOSED

REVISIONS				
ECN	REV.	DESCRIPTION	DATE	APPROVED
1256	A	FIRST RELEASE	2024/10/08	XY

Specification:	
<b>Fuse</b>	F1 : Polyswitch 750mA Polyswitch device resets after the fault is cleared and power to the circuit is removed
<b>Power Supply</b>	Voltage: 24VDC nominal, range 18 to 30VDC 24VAC nominal, range 15 to 24VAC 50/60HZ Note: Input Power is half-wave rectifier circuit, it can be either floating or grounded. You will damage devices if you mix half wave and full wave rectifiers on the same AC source. Use extreme caution when sharing a common AC source. Sharing a common DC source is less problematic.  The AO-Box can share the same AC or DC power supply with Q-Controller, as Q-Controller is half-wave rectifier inside.  Current: max. 0.75 A (fuse protected) Actual running current < 0.3A
<b>Address</b>	Address can be defined from 0 to 15 with the four solder pads J2, J3, J4 and J5 Factory Default address is 0 with J2= OPEN, J3= OPEN, J4= OPEN, J5=OPEN
<b>Panel Indicators</b>	TX/RX status RS-485 port TX/RX Status for Q-Controller Network

**PROPRIETARY AND CONFIDENTIAL**  
THE INFORMATION CONTAINED IN THIS DRAWING IS THE SOLE PROPERTY OF QUATROSENSE ENVIRONMENTAL LTD. ANY REPRODUCTION IN PART OR AS A WHOLE WITHOUT THE WRITTEN PERMISSION OF QUATROSENSE ENVIRONMENTAL LTD IS PROHIBITED.

UNLESS OTHERWISE SPECIFIED:		NAME	DATE	Greystone Energy Systems Inc.
DIMENSIONS ARE IN INCHES		XY	24/10/08	
TOLERANCES:				
FRACTIONAL: ±				
ANGULAR: MACH ±				
BEND ±				
TWO PLACE DECIMAL ±				
THREE PLACE DECIMAL ±				
INTERPRET GEOMETRIC TOLERANCING PER:				
MATERIAL				
FINISH				
NEXT ASSY	USED ON			
APPLICATION				
DO NOT SCALE DRAWING				
TITLE:		AO-BOX, GES Installation Drawing		
SIZE	DWG. NO.	REV		
<b>B</b>	86550-004-005	<b>A</b>		
SCALE: 1:2		WEIGHT:	SHEET 1 OF 3	

# Recommend Connection for New Installations

REVISIONS				
ZONE	REV.	DESCRIPTION	DATE	APPROVED
-	-	See Sheet1	-	-

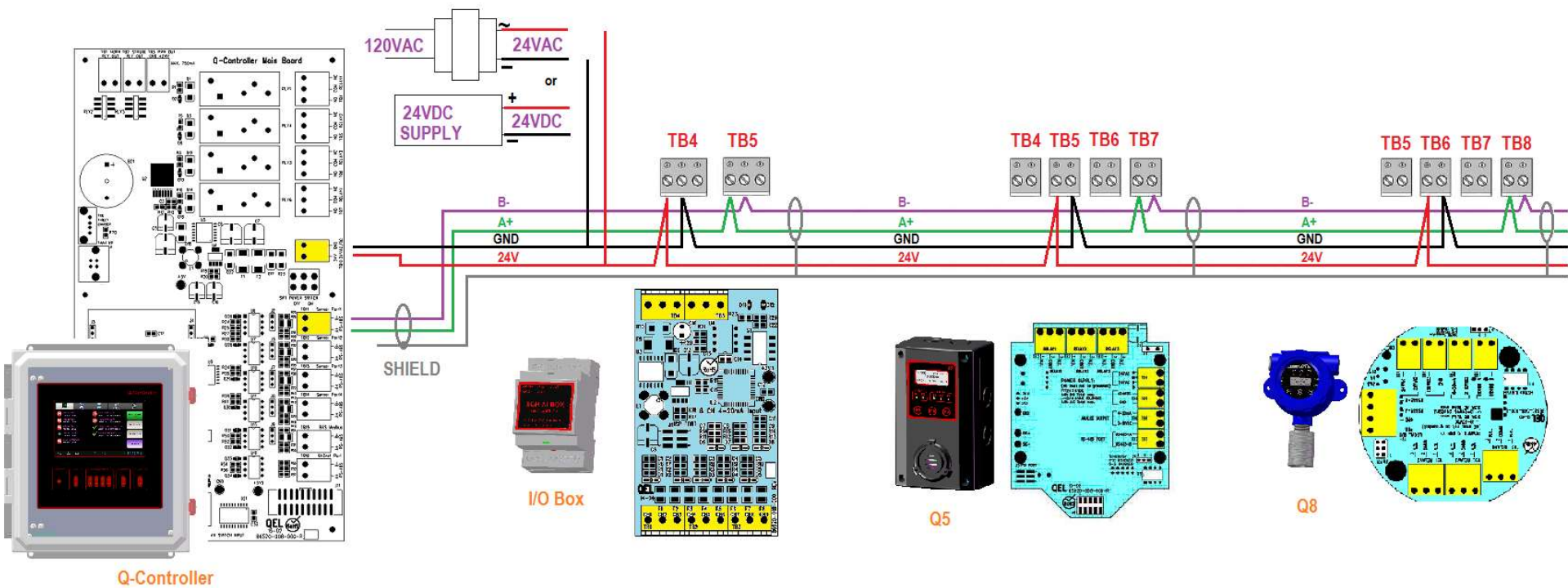

- Note:
1. The power supply can be 24VAC or DC as every device uses a half-wave rectifier in the drawing
  2. The power negative may be grounded or floating
  3. Don't mix full wave rectifiers device with this system
  4. RS-485 cable should be wired from one sensor to another without tees or stub. Power cable does not matter
  5. Before power up, the polarity of the 24VAC power supply should be checked carefully, reversing polarity on the network will cause the RS-485 driver chips blow up
  6. The I/O Box in the drawing can be AI-Box, AO-Box, BI-Box or BO-Box

**PROPRIETARY AND CONFIDENTIAL**  
 THE INFORMATION CONTAINED IN THIS DRAWING IS THE SOLE PROPERTY OF QUATROSENSE ENVIRONMENTAL LTD. ANY REPRODUCTION IN PART OR AS A WHOLE WITHOUT THE WRITTEN PERMISSION OF QUATROSENSE ENVIRONMENTAL LTD IS PROHIBITED.

		UNLESS OTHERWISE SPECIFIED:		NAME	DATE	Greystone Energy Systems Inc.	
		DIMENSIONS ARE IN INCHES		DRAWN			TITLE: AO-Box, GES Installation Drawing
		TOLERANCES:		CHECKED			
		FRACTIONAL: ±		ENG APPR.			
		ANGULAR: MACH ± BEND ±		MFG APPR.		SIZE DWG. NO. REV B 86550-004-005 A	
		TWO PLACE DECIMAL ±		Q.A.			
		THREE PLACE DECIMAL ±		COMMENTS:		SCALE: 1:4 1 SHEET 2 OF 3	
		INTERPRET GEOMETRIC TOLERANCING PER:					
		MATERIAL					
		FINISH					
NEXT ASSY	USED ON						
APPLICATION		DO NOT SCALE DRAWING					

# AO-BOX Connection

REVISIONS				
ZONE	REV.	DESCRIPTION	DATE	APPROVED
-	-	See Sheet1	-	-

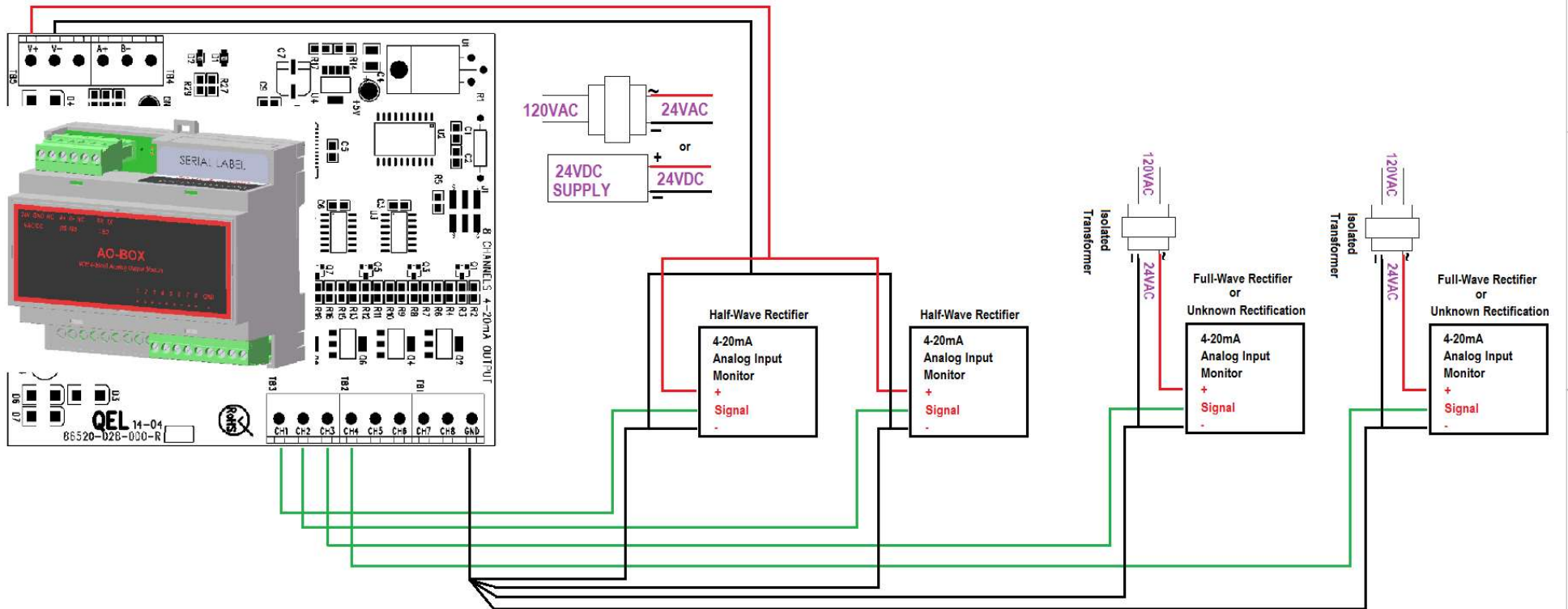

- NOTE for AO-Box:**
- AO-box is non-isolated devices with a half-wave rectifier on the 24VAC/DC power input terminal. Therefore, to prevent equipment damage, multiple devices that are powered by a common 24VAC transformer must use common device power connections (e.g. 24VAC input power to other device power inputs, and ground to other device grounds), or dedicated isolated transformers must be provided for each non-isolated device.
  - The AO-Box 24VAC/DC input power ground and analog output signal returns are common.
  - If it is known that the connected analog device is half-wave rectified, it can share the same AC power supply with the AO-Box.
  - If the rectification of the other device is unknown, it is recommended that a separate transformer is used to power other device.

**PROPRIETARY AND CONFIDENTIAL**  
 THE INFORMATION CONTAINED IN THIS DRAWING IS THE SOLE PROPERTY OF <INSERT COMPANY NAME HERE>. ANY REPRODUCTION IN PART OR AS A WHOLE WITHOUT THE WRITTEN PERMISSION OF <INSERT COMPANY NAME HERE> IS PROHIBITED.

		UNLESS OTHERWISE SPECIFIED:		NAME	DATE	Greystone Energy Systems Inc.	
		DIMENSIONS ARE IN INCHES					TITLE:
		TOLERANCES: FRACTIONAL ±					AO-Box, GES Installation Drawing
		ANGULAR: MACH ± BEND ±					SIZE DWG. NO. REV
		TWO PLACE DECIMAL ±				B 86550-004-005 A	
		THREE PLACE DECIMAL ±				SCALE: 1:4 WEIGHT: SHEET 3 OF 3	
		INTERPRET GEOMETRIC TOLERANCING PER:		COMMENTS:			
		MATERIAL					
		FINISH					
NEXT ASSY	USED ON						
APPLICATION		DO NOT SCALE DRAWING					