

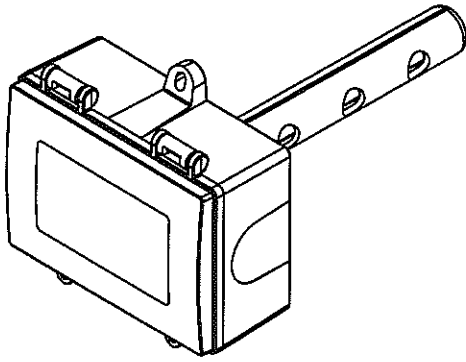

INTRODUCTION

The CO2 transmitter uses Infrared Technology to monitor CO2 levels and outputs a linear 4-20 mA or 0-5/0-10 Vdc signal. Options include an LCD, a control relay and a resistive temperature sensor. Features include a back-lit LCD and user menu for easy installation.



BEFORE INSTALLATION

Read these instructions carefully before installing and commissioning the transmitter. Failure to follow these instructions may result in product damage. Do not use in an explosive or hazardous environment, with combustible or flammable gases, as a safety or emergency stop device or in any other application where failure of the product could result in personal injury. **Take electrostatic discharge precautions during installation and do not exceed the device ratings.**

MOUNTING

The duct sensor installs on the outside of a return air duct with the sampling tube inserted into the duct. Use the included foam plug to prevent air from entering the enclosure from the conduit and causing reading errors.

Mount the sensor in an easily accessible location in a straight section of duct at least five feet from corners or other items that may cause disturbances in the air flow. Avoid areas where the detector is exposed to vibrations or rapid temperature changes.

The principal of operation is based on the Venturi effect of the probe that extends into the HVAC duct. Air flowing through the duct is forced into the vent holes on one side of the probe, into the enclosure, over the CO2 sensor and then the air is drawn back out of the enclosure via the vent holes on the opposite side of the probe.

Drill or punch a 7/8" or 1" hole in the duct at the preferred location and insert the probe into the hole to mark the enclosure mounting holes. Remove the unit and drill the two mounting holes. Clean all drilled holes of debris before mounting the device. Mount the enclosure to the duct with two sheet metal screws such that the duct air flow is parallel with the vent holes in the probe (i.e.: air flows directly into the probe holes). To prevent air leaks, ensure the gasket is compressed around the probe between the device enclosure and the air duct.

The enclosure has a hinged cover with a latch. Open the cover by pulling slightly on the latch on the bottom of the enclosure, at the same time pulling on the cover, as illustrated in Figure 3. 2

A 1/2" NPT threaded connection hole is provided in the left side of the enclosure. Screw the EMT connector or cable gland connector in until tight. See Figure 4. It is recommended that weatherproof conduit or cable gland fittings be used. The F style enclosure includes a 1/2" NPT to M16 thread adapter and cable gland fitting.

Make wiring connections as per the "Wiring" illustrations on Page 2.

Swing door closed until securely latched. For added security, 2 screws are provided that may be installed in the integrated screw tabs. See Figure 5. 4

