

Introduction

The RH transmitter uses a highly accurate and reliable Thermoset Polymer based capacitance humidity sensor and state-of-the-art digital linearization and temperature compensated circuitry to monitor humidity levels in a duct. The humidity sensor is encapsulated in a 60 micron HDPE filter at the end of a 230 mm (9") S/S probe and a compact enclosure. An optional temperature sensor is available.

Before Installation

Read these instructions carefully before installing and commissioning the RH transmitter. Failure to follow these instructions may result in product damage. Do not use in an explosive or hazardous environment, with combustible or flammable gases, as a safety or emergency stop device or in any other application where failure of the product could result in personal injury. **Take electrostatic discharge precautions during installation and do not exceed the device ratings.**

Mounting

The RH transmitter installs directly into any air duct with a minimum width/diameter of 25.5 cm (10"). Select a suitable installation area in the middle of the duct wall. To achieve the best reading, do not place in an area where air stratification may be present. **Mount the sensor at least 1.5 m (5') in either direction from elbows, dampers, filters or other duct restrictions. Avoid areas where the transmitter is exposed to vibrations or rapid temperature changes.**

Once a suitable spot is selected, drill a 32-38 mm (1.25" - 1.5") hole for the probe.

Using a Phillips screwdriver, remove the (2) cover screws, as shown in Figure 1. **The RH transmitter PCB is attached to the cover so take care not to pull on cover.** Allow cover to hang while installing, making wiring connections and set up. See Figure 2.

Slide the probe in the drilled hole until the enclosure is flush against the duct. The airflow direction is not important. Secure the enclosure to the duct with (2) #10 x 25 mm (1") self tapping screws (Not provided). Tighten screws until the enclosure is tight against the duct and that there is no movement of the enclosure as shown in Figure 3. A foam gasket is provided on the back of the enclosure that provides a tight seal against any air leaks.

A 21 mm (0.8125") hole is provided for connection of either 12.77mm (0.5") EMT or a cable gland style connector. Insert the EMT or cable gland connector through the hole and securely fasten using a locknut as shown in Figure 4. **Special care must be taken not to damage any internal components during installation.**

Make wire connections as per the "Wiring" illustrations on Page 2.

Once wiring and set up are complete, re-install cover and tighten the (2) screws using a Phillips screwdriver.

Figure 3

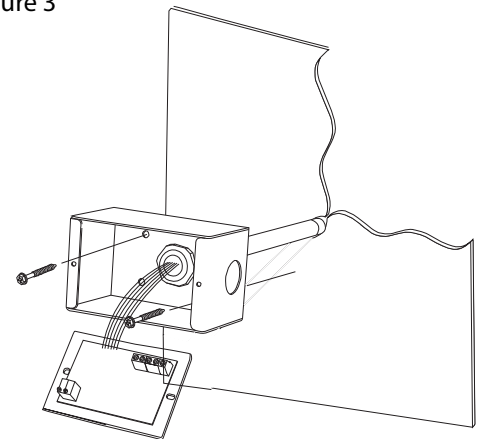

Figure 1

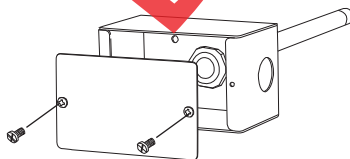

Figure 2

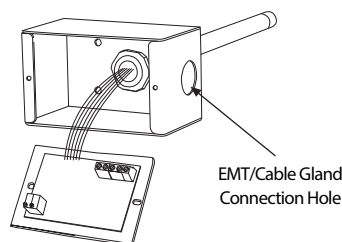
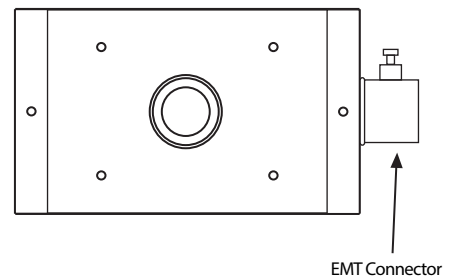
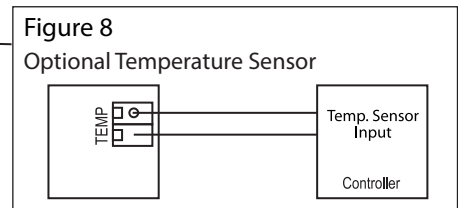
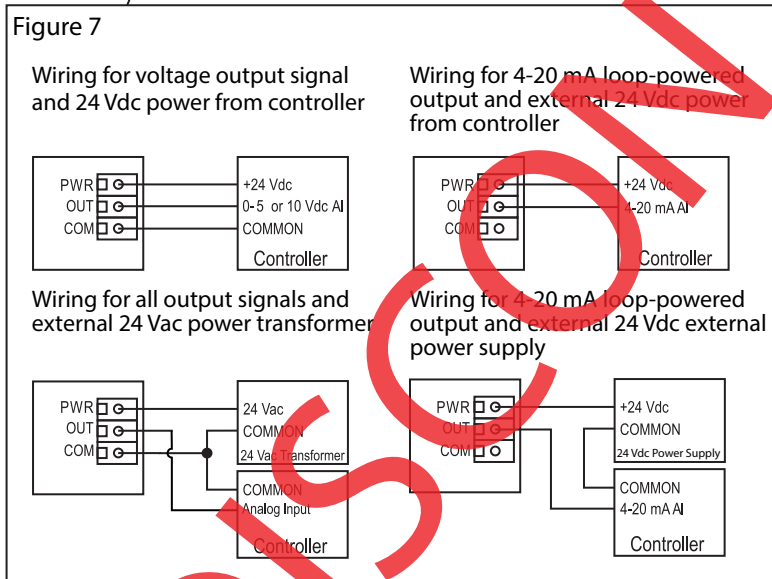
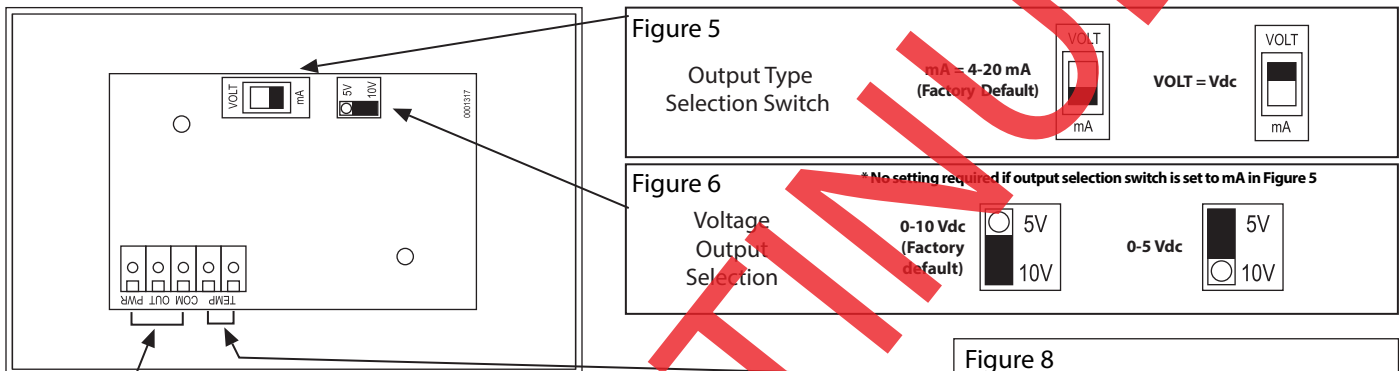

Figure 4



Wiring

- Deactivate the 24 Vac/dc power supply until all connections are made to the device to prevent electrical shock or equipment damage.
- Use 14-22 AWG shielded wiring for all connections and do not locate the device wires in the same conduit with wiring used to supply inductive loads such as motors. Make all connections in accordance with national and local codes.
- Pull at least six inches of wire through the wall and into the enclosure, then complete the wiring connection according to the wire diagram for the applicable power supply and output signal type.
- Select desired signal output type (mA or Vdc) by placing the output switch in required position, as shown in Figure 5. Factory default is mA (4-20 mA).
- If mA was selected, no further Output set up is required. If VOLT output is selected in Figure 5, place Voltage Output Jumper to desired span position, as shown in Figure 6. ie: 10 = 0-10 Vdc. Factory default is 10v = 0-10Vdc.
- Connect the DC positive or the AC voltage hot side to the PWR terminal. For voltage output or AC power, the supply Common is connected to the COM terminal. The device is reverse voltage protected and will not operate if connected backwards. It has a half-wave power supply so the supply Common is the same as the signal Common as shown in Figure 7.
- The analog output is available on the OUT terminal. Check the controller Analog Input to determine the proper connection before applying power as shown in Figure 7.
- If installed, the resistance temperature output is available on the two terminals labelled TEMPERATURE SENSOR as shown in See Figure 8.



Dimensions:

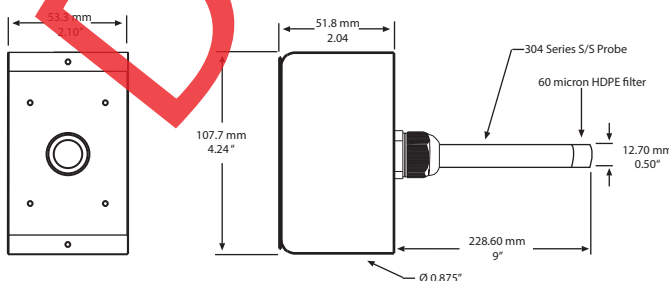

Specification:

- Sensor Type:.....Thermoset Polymer based Capacitive
 Range:.....0 to 100% RH
 Accuracy:.....±2, 3, or 5% RH (5 to 95% RH)
 Response:.....15 Seconds typical
 Temp Dependence:.....±0.05% RH/ °C
 Hysteresis:.....±1.5% RH maximum
 Repeatability:.....±0.5% RH typical
 Linearity:.....±0.5% RH typical
 Operating Range:.....-40 to 85°C (-40 to 185°F)
 Power Supply:.....18 to 30 Vdc, 15 to 26 Vac
 Consumption:.....22 mA maximum
 Protection Circuitry:.....Reverse voltage protected and output limited
 Output Signal:.....4-20 mA current loop, 0-5 or 0-10 Vdc (selectable)
 Output Drive @ 24Vdc:.....550 ohms max for current output
 10K ohms min for voltage output
 Internal Adjustments:.....Clearly marked ZERO and SPAN pots
 Optional Temp:.....RTD's or Thermistors. 2 Wire
 Probe:.....230 mm (9") probe length x 12.7 mm (1/2") diameter stainless steel with 60 micron HDPE porous filter
 Enclosure:.....Galvanized Steel - IP50 (NEMA 1)
 *In order to maintain the published NEMA/IP ratings, properly rated conduit or cable gland adapters must be used.
 Termination:.....Screw terminal block (14 to 22 AWG)