



# GREYSTONE ENERGY SYSTEMS INC

## REMOTE AUDIBLE ALARM AA-1

The AA-1 remote audible alarm is ideal for providing audible indication at station that is remote to where the monitoring is done. The AA-1 is powered with up to 48 Vdc and provides an adjustable audible alarm up to 95 db. The AA-1 is provided on a stainless steel plate which can be mounted to a single gang utility box or directly on the wall.

### SPECIFICATION:

Operating Mode:.....Medium Loud Medium Beep Tone  
 Operating Voltage:.....9-48 Vdc  
 Typical Operating Current:.....5 mA at 9 Vdc, 20 mA at 48 Vdc  
 Typical Sound Pressure:.....85 ±5 dB(A), at 9 Vdc, at 61 cm (24"), at 25°C  
 95 ±5 dB(A), at 48 Vdc, at 61 cm (24"), at 25°C  
 Termination:.....Quick Connect Blades with Screws  
 Termination Strength:.....Pull test with a maximum of 10 kg (22 lb) load  
 Operating Temperature:.....-20° to +65°C (-4° to +149°F)  
 Surge Voltage:.....20% over maximum rated voltage for less than 5 minutes  
 Reverse Voltage Protection:.....To the maximum operating voltage  
 Construction Materials:.....Internal Circuit- Audio-oscillator and piezoelectric driver  
 Potting- 2 parts epoxy resin or silicone, black  
 Diaphragm- Stainless Steel 304

Gasket:

Environmental Durability:.....ASTM B117 Certified - Withstands exposure to salt spray for 300 hours  
 IP 68 Certified - Withstands water submergence and dust exposure  
 Humidity- 95% RH at +40\_C continuously for 100 hours.  
 Vibration- Withstands vibration between 0 and 55 Hz. on all axes.

Life Expectancy:.....10 years under normal operating conditions.

Mounting:.....Panel Mounted on a single gang, stainless steel wall plate with Volume Control

### TYPICAL INSTALLATION:

**For complete installation and wiring details, please refer to the product installation instructions.**

The AA-1 series can be flush mounted directly to a single gang electrical box or directly to a wall using wall anchors.

Quick connect blades with screws are provided for connection to the monitored device or to a building automation system.

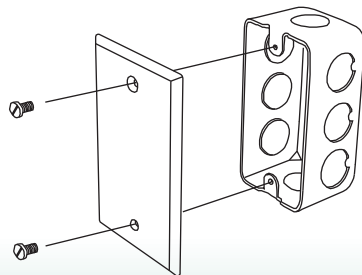

### PRODUCT ORDERING INFORMATION:

MODEL	Product Description
AA-1	Remote Audible Alarm

### DIMENSIONS:

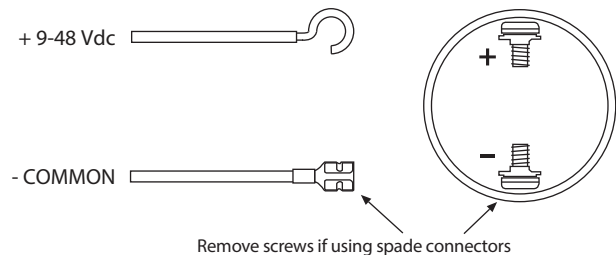
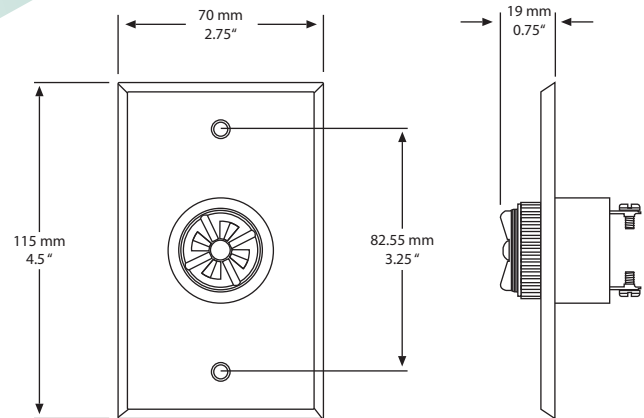

Greystone Energy Systems, Inc. reserves the right to make design modifications without prior notice.

Greystone Energy Systems, Inc. (506) 853-3057 Fax: (506) 853-6014  
 150 English Drive, Moncton, North America: 1-800-561-5611  
 New Brunswick, Canada E1E 4G7 e-mail: mail@greystoneenergy.com  
 www.greystoneenergy.com

RoHS COMPLIANT

