

**Introduction**

The Network Sensor features embedded BACnet and ModBus communication and is available in several configurations for the most efficient monitoring and control solution. The basic unit accurately measures room temperature and can also include RH measurement, up/down setpoint control, a local override function, a control relay output and a fan speed switch.

The device connects to an RS-485 MS/TP network to offer a single-point solution for control of indoor air quality and comfort. Features include a back-lit LCD and user menu for easy installation, field-proven sensors and user input controls to add local setpoint and override functions at the same network point.

**Before Installation**

Read these instructions carefully before installing and commissioning the device. Failure to follow these instructions may result in product damage. Do not use in an explosive or hazardous environment, with combustible or flammable gases, as a safety or emergency stop device or in any other application where failure of the product could result in personal injury. Take electrostatic discharge precautions during installation and do not exceed the device ratings.

**Set-up**

The device parameters must be set before connection to the network and will ensure each device will have a unique address and the correct baud rate.

For BACnet, the MAC address is appended to the Device Object : Vendor Identifier to create the unique Device Instance (Device Object : Object Identifier). Once connected to a network, the Device Object : Object Identifier can be written to any unique value via BACnet.

Once set, all parameters are saved in non-volatile memory. The local menu and LCD are used to set the BACnet MAC device address (0-127) or the ModBus address (1-255) and the baud rate. The factory defaults are address 3 and 9600 baud. The menu and setup procedure is described in the Setup Menu section.

**Mounting**

The room type sensor installs directly on a standard electrical box and should be mounted five feet from the floor of the area to be controlled. Do not mount the sensor near doors, opening windows, supply air diffusers or other known air disturbances. Avoid areas where the detector is exposed to vibrations or rapid temperature changes.

The cover is hooked to the base at the top edge and must be removed from the bottom edge first. Use a small screwdriver to carefully pry each bottom corner if necessary. If a security screw is installed on the bottom edge, then it may have to be loosened or removed also. Tip the cover away from the base and sit it aside.

The pcb must be removed from the base to access the mounting holes. Follow usual anti-static procedures when handling the pcb and be careful not to touch the sensors. The pcb is removed by pressing the enclosure base to unsnap the latch near the bottom edge, then the pcb can be lifted out of the base. Sit the pcb aside until the base is mounted on the wall.

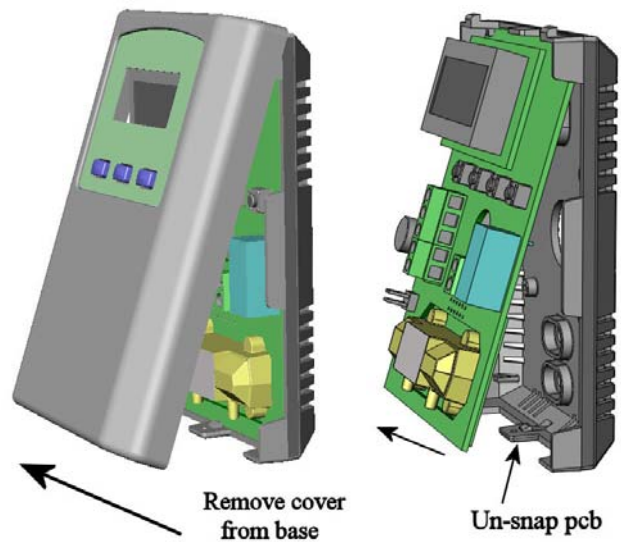

After the base is screwed to an electrical box or the wall using the appropriate holes, pull the wires through the wiring hole in the center of the pcb and then reinstall it in the enclosure base. Ensure the pcb is snapped into the base securely and correctly.

The mounting hole locations are shown in the following drawing.

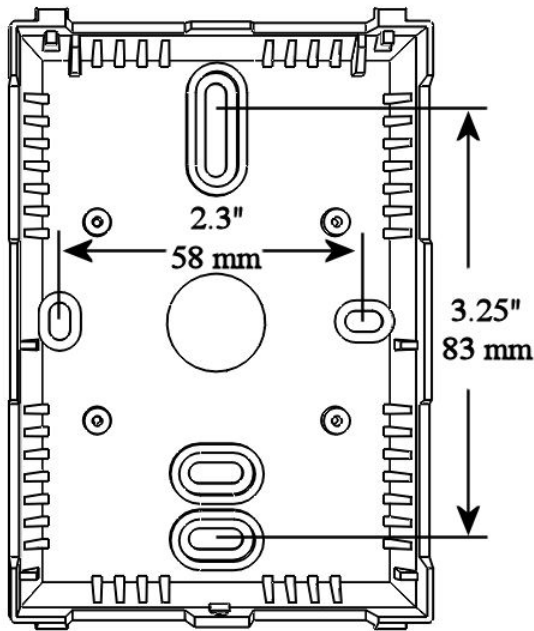

**Wiring**

Deactivate the 24 Vac/dc power supply until all connections are made to the device to prevent electrical shock or equipment damage. Follow proper electrostatic discharge (ESD) handling procedures when installing the device or equipment damage may occur. Use 22 AWG shielded wiring for all connections and do not locate the device wires in the same conduit with wiring used to supply inductive loads such as motors. Make all connections in accordance with national and local codes.

Connect the 24 Vac/dc power supply to the terminals labeled **POWER** and **COMMON**. Use caution if 24 Vac power is used and one side of the transformer is earth-grounded. In general, the transformer should NOT be connected to earth ground when using devices with RS-485 network connections. The device is reverse voltage protected and will not operate if connected backwards.

Connect the RS-485 network with twisted shielded pair to the terminals marked **A(-)**, **B(+)** and **SHIELD**. The positive wire connects to **B(+)** and the negative wire connects to **A(-)** and the cable shield must be connected to the **SHIELD** terminal on each device. If the device is installed at either end of an RS-485 network, an end-of-line (EOL) termination resistor (121 ohm) should be installed in parallel to the A(-) and B(+) terminals. This device includes a network termination jumper and will connect the 121 ohm resistor correctly on the pcb. Simply move the jumper to the EOL position and no external resistor is required. The ground wire of the shielded pair should be connected to earth ground at the end of the network and the master is not grounded. Do not run bus wiring in the same conduit as line voltage wiring or other wiring that switches power to highly inductive loads such as contactors, coils or motors.

A network segment is a single shielded wire loop run between several devices (nodes) in a daisy chain configuration. The total segment length should be less than 4000 feet (1220 meters) and the maximum number of nodes on one segment is 64. Nodes are any device connected to the loop and include controllers, repeaters and sensors such as this one but do not include the EOL terminators. To install more than 64 devices, or to increase the network length, repeaters will be required for proper communication. The maximum daisy chain length (segment) depends on transmission speed (baud rate), wire size and number of nodes. If communication is slow or unreliable, it may be necessary to wire two daisy chains to the controller with a repeater for each segment.

An optional signal is the relay output available on the **RELAY** terminals. The relay output is completely isolated and has a Normally Open (NO) signal. This signal can be used to directly control an alarm or ventilation fan.

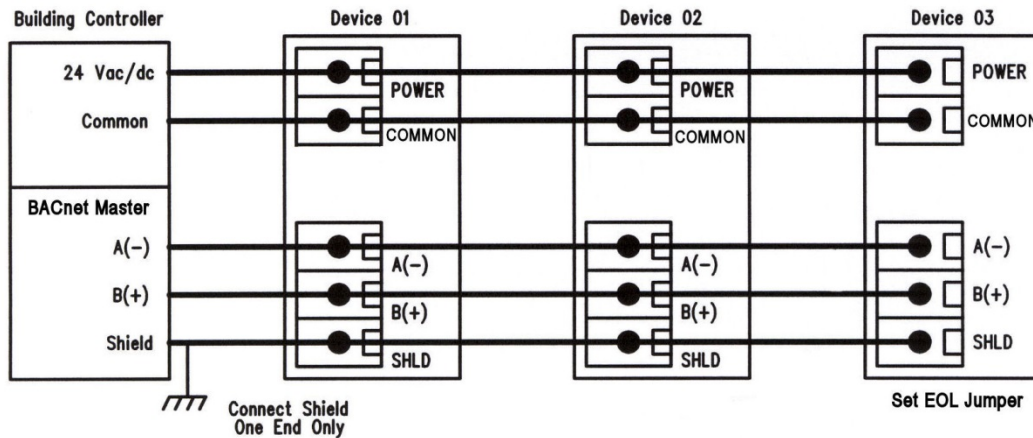

**Start-up**

Verify the transmitter is properly wired and connections are tight. Apply power and note that the LCD will indicate the software version number and then the device will begin reading the sensor values and display them on the LCD.

**Operation**

In normal operation the device reads the temperature and RH (if installed) sensors and updates the object (BACnet) or register (ModBus) values accordingly. The LCD displays the sensor values as determined by the display mode object for either temperature only, RH only, both or none. Temperature units can be set to either C or F and the display resolution can be set also.

If the device has the optional Up/Down setpoint switches installed, pressing either the <UP> or <DOWN> keys will cause the LCD to change to show the setpoint value. The first key press will display the current setting of the Up/Down control for about 5 seconds and then revert back to the sensor values again if neither the <UP> or <DOWN> keys are pressed again. To increase the setpoint, press the <UP> key while the LCD is in setpoint mode and each press will increase the setpoint up to the maximum value. To decrease the setpoint, press the <DOWN> key while the LCD is in setpoint mode and each press will decrease the setpoint down to the minimum value. After 5 seconds of no key activity, the display will revert back to normal and the new setpoint value will be saved.

The setpoint minimum and maximum values can be configured via the network as can the units for either °C, °F or %RH values.

If the device has the optional Override switch installed, pressing the <OVERRIDE> key will cause the Override object status to change and it can be reset via the network.

Network objects are available to control the OCC (occupied) LCD segment and the relay output.

If the optional Fan Speed switch is installed, it's output setting can be queried via a network object also.

More details on the above features can be found in the following sections.

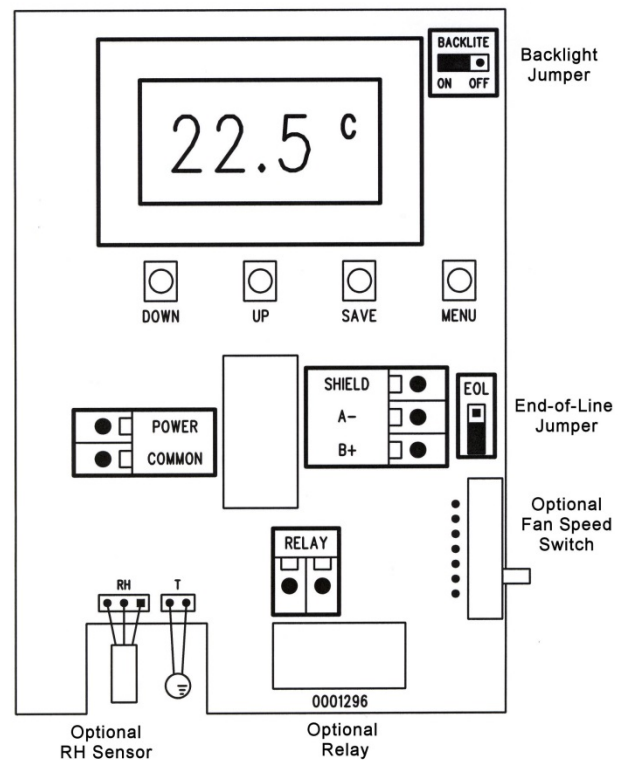

**Setup Menu**

To enter the menu, press and release the <MENU> key while in normal operation. This will enter the Setup menu step 1, pressing the <MENU> key a second time advances to step 2. Each press of the <MENU> key advances the menu item. No values are saved or changed by using the <MENU> key. The <UP> and <DOWN> keys are used to make changes to program variables by scrolling through the available options. When a value is changed, use the <SAVE> key to save it to memory and advance to the next menu item. Actual menu displays with the default value are shown.

<MENU> Press and release the <MENU> key to enter the Setup menu.

- 1.  **Network Protocol**  
Use <UP> or <DOWN> to select either bAC (BACnet) or bUS (ModBus) protocol. Press <SAVE> to save the value. The default is bAC (BACnet).

<MENU>

- 2.  **Network Address**  
Press <UP> or <DOWN> to select a unique network address. It can be set from 1-255 for ModBus or from 0-127 for BACnet. The default address is 3. Press <SAVE> to save the setting and advance the menu.

<MENU>

- 3.  **Baud Rate**  
Use <UP> or <DOWN> to select a baud rate of 30 (300), 60 (600), 120 (1200), 240 (2400), 480 (4800), 960 (9600) or 192 (19200) for ModBus or 960 (9600), 192 (19200), 384 (38400) or 768 (76800) for BACnet. The default baud rate is 960 (9600). Press <SAVE> to save the setting and advance the menu.

<MENU>

**Items 4 to 7 are only shown if the protocol is set to ModBus RTU in Step 1**

- 4.  **ModBus Parity**  
Use <UP> or <DOWN> to select a parity value of n (none), O (odd) or E (even). The default ModBus parity bit is n (none). Press <SAVE> to save the value.

<MENU>

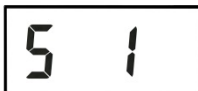
- 5.  **ModBus Stop Bits**  
Use <UP> or <DOWN> to set the stop bits to 1 or 2. The default ModBus stop bits is 1.

<MENU>

- 6.  **ModBus CRC**  
Use <UP> or <DOWN> to select a CRC value of 1 (A001 = CRC-16 reverse), 2 (1021 = CITT), 3 (8005 = CRC-16) or 4 (8408 = CITT reverse). The default CRC is 1 (polynomial is 0XA001).

<MENU>

- 7.  **ModBus Delay**  
Use <UP> or <DOWN> to change the value from 0 (minimum) to 50, 100, 150, 200, 250, 300 or 350 ms. The factory default slave response delay is 0 (minimum). *Minimum delay means just more than 3.5 character time delays, 4ms for 9600 baud rate, for example.*

<MENU> Exits the menu and returns to normal operation.

**BACnet Protocol**

Using the BACnet system software, only map the point objects that are installed and required. Excessive point mapping will lower the network performance. Some objects will not be available if the hardware option is not installed. For example, AI 3 will not be available if there is no Fan Speed control installed. This could also be the case if the device has no RH, setpoint or relay options.

This can be determined via BACnet by checking the Reliability, Event State or Status Flags properties of the optional objects.

If the hardware is not installed, the Reliability property will return NO\_SENSOR and the Event\_State property will indicate FAULT if the related hardware is not installed. To reduce network traffic, these points should not be polled.

The device has several BACnet objects to identify the device, read current values, configure the device and calibrate the sensors. There are four standard supported BACnet object types as shown below.

<b>Object Type</b>	<b>Dynamically Creatable</b>	<b>Dynamically Deletable</b>	<b>Object Identifier</b>	<b>Object Name</b>
Device	No	No	381003	STAT 003
Analog Input	No	No	AI 1 AI 2 AI 3 AI 4	Temperature Relative Humidity Fan Speed Setpoint
Analog Value	No	No	AV 1 AV 2 AV 3 AV 4 AV 5 AV 6 AV 7	Temperature Offset RH Offset Setpoint Minimum Setpoint Maximum Display Mode Override Mode Override Mode Time
Binary Value	No	No	BV 1 BV 2 BV 3 BV 4 BV 5 BV 6 BV 7	Temperature Units Temperature Resolution OCC Enable Override Status Relay Enable Setpoint Mode Setpoint Resolution

The BACnet Device object allows configuration of the device. Device object properties are shown below.

Property	Default Value	Property Data Type	Access
Object Identifier	381003	BACnetObjectIdentifier(numeric)	Read / Write
Object Name	STAT 003	CharacterString (32)	Read / Write
Object Type	DEVICE (8)	BACnetObjectType	Read
System Status	OPERATIONAL (0)	BACnetDeviceStatus	Read
Vendor Name	Greystone Energy Systems	CharacterString	Read
Vendor Identifier	381	Unsigned16	Read
Model Name	STAT	CharacterString	Read
Firmware Revision	1.2	CharacterString	Read
Application Software Version	V1.0	CharacterString	Read
Location	150 English Drive, Moncton, NB	CharacterString (32)	Read / Write
Description	Greystone Temperature Sensor	CharacterString (32)	Read / Write
Protocol Version	1	Unsigned	Read
Protocol Revision	14	Unsigned	Read
Protocol Services Supported	See description below	BACnetServicesSupported	Read
Protocol Object Types Supported	See description below	BACnetObjectTypesSupported	Read
Object List	See description below	BACnetArray	Read
Maximum APDU Length Accepted	50, B'0000'	Unsigned	Read
Segmentation Supported	NO_SEGMENTATION (3)	BACnetSegmentation	Read
APDU Timeout	6,000	Unsigned	Read / Write
Number of APDU Retries	3	Unsigned	Read / Write
Max Master	127	Unsigned	Read / Write
Max Info Frames	1	Unsigned	Read
Device Address Binding	empty	BACnetAddressBinding	Read
Database Revision	0	Unsigned	Read
Property List		BACnetArray	Read

**Object Identifier** Initial default number is 381003, where 381 is the vendor ID and 003 is the default network MAC address. When the MAC address is initially changed the value is updated and saved. For example, if the MAC address is set to 50 via the Setup Menu for startup, then the device instance will be set to 381050. This property is also writable via BACnet. If the Device:Object\_Identifier is written to via BACnet then the MAC address is no longer appended to the vendor ID to create this value.

**Object Name** Initial string is “ STAT 003” where STAT is the device model name and 003 is the default network address. Can be written with a new string of maximum length of 32 characters and the value is saved. The “003” is the MAC address as set by the menu and is automatically changed if the MAC address is changed. Once written to via BACnet, the MAC address no longer gets appended to the value.

**Protocol Services Supported** readProperty, writeProperty, deviceCommunicationControl, who-Has, who-Is  
Binary bit string = {00000000 00001001 01000000 00000000 01100000 0}

**Protocol Object Types Supported** Analog\_Input, Analog\_Value, Binary\_Value, Device  
Binary bit string = {10100100 10000000 00000000 00000000 00000000 00000000 00000000}

**Object List** ((Device, Instance 3), (Analog Input, Instance 1), (Analog Input, Instance 2), (Analog Input, Instance 3), (Analog Input, Instance 4), (Analog Value, Instance 1), (Analog Value, Instance 2), (Analog Value, Instance 3), (Analog Value, Instance 4), (Analog Value, Instance 5), (Binary Value, Instance 1), (Binary Value, Instance 2), (Binary Value, Instance 3), (Binary Value, Instance 4), (Binary Value, Instance 5), (Binary Value, Instance 6), (Binary Value, Instance 7))

**APDU Timeout** Value is 6,000. Can be modified from 1 to 10,000.  
**Number Of APDU Retries** Value is 3. Can be modified from 1 to 10.  
**Max Master** Value is 127. Value is saved. Can be modified from 1 to 127.  
**Database Revision** Value is 0 to 255.

The analog input BACnet objects allow reading of sensor values and indicate which options are present via the Reliability property. Analog input object properties are shown below.

**Analog Input Object Temperature** (Present Value is current temperature sensor reading in°F or °C, resolution is 0.1°)  
(The temperature units default to °C but can be changed to °F using BV1)

Property	Default Value	Property Data Type	Access
Object Identifier	AI1 (Analog Input 1)	BACnetObjectIdentifier	Read
Object Name	Temperature	CharacterString (32)	Read
Object Type	ANALOG_INPUT (0)	BACnetObjectType	Read
Present Value	current reading	Real	Read
Description	Temperature	CharacterString (32)	Read
Device Type	Space Temperature Sensor	CharacterString (32)	Read
Status Flags	{false, false, false, false} (0000)	BACnetStatusFlags	Read
Event State	NORMAL (0)	BACnetEventState	Read
Reliability	NO_FAULT_DETECTED (0)	BACnetReliability	Read
Out of Service	FALSE (0)	Boolean	Read
Units	degrees-Fahrenheit (64) or degrees-Celsius (62)	BACnetEngineeringUnits	Read
Property List		BACnetArray	Read

**Analog Input Object Relative Humidity** (Present Value is current RH sensor reading in %RH, resolution is 1%)  
(If this option is not installed, the Status Flags, Event State and Reliability property values change)

Property	Default Value	Property Data Type	Access
Object Identifier	AI2 (Analog Input 2)	BACnetObjectIdentifier	Read
Object Name	Relative Humidity	CharacterString (32)	Read
Object Type	ANALOG_INPUT (0)	BACnetObjectType	Read
Present Value	current reading	Real	Read
Description	Relative Humidity	CharacterString (32)	Read
Device Type	0-100 %RH Sensor	CharacterString (32)	Read
Status Flags	{false, false, false, false} (0000) or (1100) if no sensor	BACnetStatusFlags	Read
Event State	NORMAL (0) or FAULT (1) if no sensor	BACnetEventState	Read
Reliability	NO_FAULT_DETECTED (0) or NO_SENSOR (1)	BACnetReliability	Read
Out of Service	FALSE (0)	Boolean	Read
Units	Percent-relative-humidity (29)	BACnetEngineeringUnits	Read
Property List		BACnetArray	Read

**Analog Input Object Fan Speed** (Present Value is current fan speed switch setting, Auto=0, Off=1, Low=2, Med=3, High=4)  
(If this option is not installed, the Status Flags, Event State and Reliability property values change)

Property	Default Value	Property Data Type	Access
Object Identifier	AI3 (Analog Input 3)	BACnetObjectIdentifier	Read
Object Name	Fan Speed	CharacterString (32)	Read
Object Type	ANALOG_INPUT (0)	BACnetObjectType	Read
Present Value	current reading	Real	Read
Description	Fan Speed	CharacterString (32)	Read
Device Type	Auto/Off/Low/Med/High Fan Speed	CharacterString (32)	Read
Status Flags	{false, false, false, false} (0000) or (1100) if no sensor	BACnetStatusFlags	Read
Event State	NORMAL (0) or FAULT (1) if no sensor	BACnetEventState	Read
Reliability	NO_FAULT_DETECTED (0) or NO_SENSOR (1)	BACnetReliability	Read
Out of Service	FALSE (0)	Boolean	Read
Units	no-units (95)	BACnetEngineeringUnits	Read
Property List		BACnetArray	Read

**Analog Input Object Setpoint**

(Default Present Value is current value from 18-24 °C. Resolution is 1 °C)  
 (If this option is not installed, the Status Flags, Event State and Reliability property values change)

Property	Default Value	Property Data Type	Access
Object Identifier	AI4 (Analog Input 4)	BACnetObjectIdentifier	Read
Object Name	Setpoint	CharacterString (32)	Read
Object Type	ANALOG_INPUT (0)	BACnetObjectType	Read
Present Value	current reading	Real	Read
Description	Setpoint Value	CharacterString (32)	Read
Device Type	Setpoint Control	CharacterString (32)	Read
Status Flags	{false, false, false, false} (0000) or (1100) if no sensor	BACnetStatusFlags	Read
Event State	NORMAL (0) or FAULT (1) if no sensor	BACnetEventState	Read
Reliability	NO_FAULT_DETECTED (0) or NO_SENSOR (1)	BACnetReliability	Read
Out of Service	FALSE (0)	Boolean	Read
Units	°C (62) or °F (64) or %RH (29)	BACnetEngineeringUnits	Read
Property List		BACnetArray	Read

The Setpoint object can be configured in various ways as required by the application:

- Use BV6 to configure the Setpoint Mode to either Temperature or RH.
- Use AV3 to configure the Setpoint Minimum value.
- Use AV4 to configure the Setpoint Maximum value.
- Use BV7 to set the Setpoint Resolution (for Temperature Setpoint Mode only).

Note that the Temperature Setpoint Mode units are the same as the Temperature Analog Input (AI1) units as controlled by BV1 (Temperature Units).

See the descriptions for AV3, AV4, BV6 and BV7 for more details.

If installed, the factory default setpoint operation is 18 to 24 °C in 1°C increments.



The analog value BACnet objects allow device configuration, sensor offset calibration and indicate which options are present via the Event State and Status Flags properties. Analog value object properties are shown below.

**Analog Value Object Temperature Offset** (Present Value defaults to 0 for no offset. Can be set from -10 to +10 Δ°F or -5.0 to +5.0 Δ°C)  
 (Units depend on the device units, either °C or °F), (°C resolution = 0.5, °F resolution = 1)

Property	Default Value	Property Data Type	Access
Object Identifier	AV1 (Analog Value 1)	BACnetObjectIdentifier	Read
Object Name	Temperature Offset	CharacterString (32)	Read
Object Type	ANALOG_VALUE (2)	BACnetObjectType	Read
Present Value	0	Real	Read / Write
Description	Temperature Offset Calibration	CharacterString (32)	Read
Status Flags	{false, false, false, false} (0000)	BACnetStatusFlags	Read
Event State	NORMAL (0)	BACnetEventState	Read
Out of Service	FALSE (0)	Boolean	Read
Units	delta-degrees-Fahrenheit (120) or Δ°C (121)	BACnetEngineeringUnits	Read
Property List		BACnetArray	Read

**Analog Value Object RH Offset** (Present Value defaults to 0 for no offset. Can be set from -10 to +10 %RH, resolution = 1)  
 (If the RH option is not installed, the Status Flags and Event State property values change)

Property	Default Value	Property Data Type	Access
Object Identifier	AV2 (Analog Value 2)	BACnetObjectIdentifier	Read
Object Name	RH Offset	CharacterString (32)	Read
Object Type	ANALOG_VALUE (2)	BACnetObjectType	Read
Present Value	0	Real	Read / Write
Description	RH Offset Calibration	CharacterString (32)	Read
Status Flags	{false, false, false, false} (0000) or (1100) if no RH sensor	BACnetStatusFlags	Read
Event State	NORMAL (0) or FAULT (1) if no RH sensor	BACnetEventState	Read
Out of Service	FALSE (0)	Boolean	Read
Units	percent-relative-humidity (29)	BACnetEngineeringUnits	Read
Property List		BACnetArray	Read

**Analog Value Object Setpoint Minimum** (Present Value default changes depending on the Setpoint Mode and Temperature Units settings)  
 (If the setpoint option is not installed, the Status Flags and Event State property values change)

Property	Default Value	Property Data Type	Access
Object Identifier	AV3 (Analog Value 3)	BACnetObjectIdentifier	Read
Object Name	Setpoint Minimum	CharacterString (32)	Read
Object Type	ANALOG_VALUE (2)	BACnetObjectType	Read
Present Value	* See notes below	Real	Read / Write
Description	Setpoint Minimum Value	CharacterString (32)	Read
Status Flags	{ false, false, false, false } (0000) or (1100) if no setpoint	BACnetStatusFlags	Read
Event State	NORMAL (0) or FAULT (1) if no setpoint	BACnetEventState	Read
Out of Service	FALSE (0)	Boolean	Read
Units	°C (62) or °F (64) or %RH (29)	BACnetEngineeringUnits	Read
Property List		BACnetArray	Read

\* Notes      The factory default Setpoint Mode is Temperature and °C with a range of 18 to 24 in 1° increments.  
 Factory default Setpoint Minimum is 18 °C, 65 °F or 40 %RH.  
 The Setpoint Mode can be set to either Temperature or RH using BV6.  
     In Temperature mode, Setpoint Minimum : Present Value may be set from 10.0 to 20.0 °C or 50.0 to 68.0 °F.  
     In RH mode, Setpoint Minimum : Present Value may be set from 10 to 60 %RH.  
 The temperature setpoint resolution may be changed from 1° to 0.5° using BV7.

**Analog Value Object Setpoint Maximum** (Present Value default changes depending on the Setpoint Mode and Temperature Units settings)  
 (If the setpoint option is not installed, the Status Flags and Event State property values change)

Property	Default Value	Property Data Type	Access
Object Identifier	AV4 (Analog Value 4)	BACnetObjectIdentifier	Read
Object Name	Setpoint Maximum	CharacterString (32)	Read
Object Type	ANALOG_VALUE (2)	BACnetObjectType	Read
Present Value	** See notes below	Real	Read / Write
Description	Setpoint Maximum Value	CharacterString (32)	Read
Status Flags	{ false, false, false, false } (0000) or (1100) if no setpoint	BACnetStatusFlags	Read
Event State	NORMAL (0) or FAULT (1) if no setpoint	BACnetEventState	Read
Out of Service	FALSE (0)	Boolean	Read
Units	°C (62) or °F (64) or %RH (29)	BACnetEngineeringUnits	Read
Property List		BACnetArray	Read

\*\* Notes      The factory default Setpoint Mode is Temperature and °C with a range of 18 to 24 in 1° increments.  
 Factory default Setpoint Maximum is 24 °C, 75 °F or 60 %RH.  
 The Setpoint Mode can be set to either Temperature or RH using BV6.  
     In Temperature mode, Setpoint Maximum : Present Value may be set from 20.0 to 30.0 °C or 68.0 to 86.0 °F.  
     In RH mode, Setpoint Maximum : Present Value may be set from 30 to 80 %RH.  
 The temperature setpoint resolution may be changed from 1° to 0.5° using BV7.

\*\*\* Notes    The following setpoint conditions are enforced:  
     Setpoint Maximum must be > Setpoint Minimum.  
     For Temperature Setpoint Mode, the minimum span (Setpoint Maximum - Setpoint Minimum) = 4 °C / °F.  
     For RH Setpoint Mode, the minimum span = 10 %RH.  
 Writing to BV1 (Temperature Units) or BV6 (Setpoint Mode) always resets Setpoint Min and Max to the factory defaults, so configure these values first.

**Analog Value Object Display Mode** (Present Value defaults change depending on the device hardware configuration)

Property	Default Value	Property Data Type	Access
Object Identifier	AV5 (Analog Value 5)	BACnetObjectIdentifier	Read
Object Name	Display Mode	CharacterString (32)	Read
Object Type	ANALOG_VALUE (2)	BACnetObjectType	Read
Present Value	* See note below	Real	Read / Write
Description	LCD Display Mode	CharacterString (32)	Read
Status Flags	{false, false, false, false} (0000)	BACnetStatusFlags	Read
Event State	NORMAL (0)	BACnetEventState	Read
Out of Service	FALSE (0)	Boolean	Read
Units	no-units (95)	BACnetEngineeringUnits	Read
Property List		BACnetArray	Read

\* Notes  
 This object controls the information that is displayed on the LCD in the normal operating mode.  
 The available settings are: 0 = no display, no backlight (menu and backlight will still display for setup)  
 (setpoint and backlight will still display if UP or DOWN pressed, if installed)  
 1 = Temperature value only displayed  
 2 = RH value only displayed  
 3 = Temperature and RH values toggle every 5 seconds  
 A temperature only device will not have options 2 or 3 (the default = 1).  
 A temperature plus RH device has default = 3.

**Analog Value Object Override Mode** (If the override option is not installed, the Status Flags and Event State properties change)

Property	Default Value	Property Data Type	Access
Object Identifier	AV6 (Analog Value 6)	BACnetObjectIdentifier	Read
Object Name	Override Mode	CharacterString (32)	Read
Object Type	ANALOG_VALUE (2)	BACnetObjectType	Read
Present Value	* See note below	Real	Read / Write
Description	Override Switch Mode	CharacterString (32)	Read
Status Flags	{false, false, false, false} (0000) or (1100) if no override	BACnetStatusFlags	Read
Event State	NORMAL (0) or FAULT (1) if no override	BACnetEventState	Read
Out of Service	FALSE (0)	Boolean	Read
Units	no-units (95)	BACnetEngineeringUnits	Read
Property List		BACnetArray	Read

\* Notes  
 This object controls the way that the front panel override switch functions.  
 The available settings are: 0 = LATCH, reset the override by writing 0 to Override Status (BV4)  
 (this is the default value)  
 1 = TOGGLE, the override status changes state whenever the switch is pressed  
 (there is a minimum time of 10 sec enforced between state changes)  
 2 = MOMENTARY, the override status self-resets after a time period  
 (the time period is set with AV7)

**Analog Value Object  
Override Mode Time**

(If the override option is not installed, the Status Flags and Event State properties change)  
(Present\_Value defaults to 1 minute. Can be set from 1 to 60 minutes. Resolution is 1 min)

Property	Default Value	Property Data Type	Access
Object Identifier	AV7 (Analog Value 7)	BACnetObjectIdentifier	Read
Object Name	Override Mode Time	CharacterString (32)	Read
Object Type	ANALOG_VALUE (2)	BACnetObjectType	Read
Present Value	1	Real	Read / Write
Description	Override Mode Time	CharacterString (32)	Read
Status Flags	{false, false, false, false} (0000) or (1100) if no override	BACnetStatusFlags	Read
Event State	NORMAL (0) or FAULT (1) if no override	BACnetEventState	Read
Out of Service	FALSE (0)	Boolean	Read
Units	Minutes (72)	BACnetEngineeringUnits	Read
Property List		BACnetArray	Read

\* Notes AV7 only has effect if AV6 is set to 2 = MOMENTARY. In this case, the Override Status value will reset to 0 after AV7 has expired.

The binary value BACnet objects allow configuration of the device, override switch status and relay control. The Event State, Status Flags and Reliability properties will indicate which options are present. Binary value object properties are shown below.

**Binary Value Object  
Temperature Units** (Present Value defaults to 0 (INACTIVE) for Celsius. Can be set to 1 (ACTIVE) for Fahrenheit)

Property	Default Value	Property Data Type	Access
Object Identifier	BV1 (Binary Value 1)	BACnetObjectIdentifier	Read
Object Name	Temperature Units	CharacterString (32)	Read
Object Type	BINARY_VALUE (5)	BACnetObjectType	Read
Present Value	INACTIVE (0)	BACnetBinaryPV	Read / Write
Description	Celsius (0) or Fahrenheit (1)	CharacterString (32)	Read
Status Flags	{false, false, false, false} (0000)	BACnetStatusFlags	Read
Event State	NORMAL (0)	BACnetEventState	Read
Reliability	NO_FAULT_DETECTED (0)	BACnetReliability	Read
Out of Service	FALSE (0)	Boolean	Read
Property List		BACnetArray	Read

**Binary Value Object Temperature Resolution** (Present Value defaults to 0 (INACTIVE) for 1°. Can be set to 1 (ACTIVE) for 0.5°)

Property	Default Value	Property Data Type	Access
Object Identifier	BV2 (Binary Value 2)	BACnetObjectIdentifier	Read
Object Name	Temperature Resolution	CharacterString (32)	Read
Object Type	BINARY_VALUE (5)	BACnetObjectType	Read
Present Value	INACTIVE (0)	BACnetBinaryPV	Read / Write
Description	1 Degree (0) or 0.5 Degree (1)	CharacterString (32)	Read
Status Flags	{false, false, false, false} (0000)	BACnetStatusFlags	Read
Event State	NORMAL (0)	BACnetEventState	Read
Reliability	NO_FAULT_DETECTED (0)	BACnetReliability	Read
Out of Service	FALSE (0)	Boolean	Read
Property List		BACnetArray	Read

\* Notes  
 The default temperature resolution is 1°. This applies to the LCD temperature display only.  
 For example: The LCD will display 22, 23, 24 °C for the temperature reading.  
 The resolution can be changed to 0.5° for the LCD temperature reading.  
 For example: The LCD will display 22.0, 22.5, 23.0 °C for the temperature reading.  
 This setting has no effect on the AI1 (Temperature) object value which has a 0.1° resolution.  
 This setting has no effect on the setpoint display resolution which is set independently.

**Binary Value Object OCC Enable** (Present Value defaults to 0 (INACTIVE) for OCC Off. Can be set to 1 (ACTIVE) for OCC On)  
 (This controls the OCC segment display on the LCD, OCC will not display if Display Mode = 0)

Property	Default Value	Property Data Type	Access
Object Identifier	BV3 (Binary Value 3)	BACnetObjectIdentifier	Read
Object Name	OCC Enable	CharacterString (32)	Read
Object Type	BINARY_VALUE (5)	BACnetObjectType	Read
Present Value	INACTIVE (0)	BACnetBinaryPV	Read / Write
Description	OCC Off (0) or OCC On (1)	CharacterString (32)	Read
Status Flags	{false, false, false, false} (0000)	BACnetStatusFlags	Read
Event State	NORMAL (0)	BACnetEventState	Read
Reliability	NO_FAULT_DETECTED (0)	BACnetReliability	Read
Out of Service	FALSE (0)	Boolean	Read
Property List		BACnetArray	Read

**Binary Value Object** (Present Value is normally 0, changes to 1 if the override switch has been pressed)  
**Override Status** (If the override option is not installed, the Status Flags, Event State and Reliability properties change)

Property	Default Value	Property Data Type	Access
Object Identifier	BV4 (Binary Value 4)	BACnetObjectIdentifier	Read
Object Name	Override Status	CharacterString (32)	Read
Object Type	BINARY_VALUE (5)	BACnetObjectType	Read
Present Value	INACTIVE (0)	BACnetBinaryPV	Read / Write *
Description	Override Switch	CharacterString (32)	Read
Status Flags	{ false, false, false, false } (0000) or (1100) if no switch	BACnetStatusFlags	Read
Event State	NORMAL (0) or FAULT (1) if no switch	BACnetEventState	Read
Reliability	NO_FAULT_DETECTED (0) or NO_SENSOR (1)	BACnetReliability	Read
Out of Service	FALSE (0)	Boolean	Read
Property List		BACnetArray	Read

\* Notes Present Value changes to 1 (ACTIVE) if the override switch has been pressed.

The Override Status has three operating modes as set by AV6 (Override Mode).  
 It can be either manually reset by writing 0(INACTIVE) back to BV4 Present Value, or  
 it can be toggled with the override switch (press ON, press OFF), or  
 it can be self-resetting after a time period as set by AV7 (Override Mode Time).

If AV6 is set for toggle (AV6 Present Value = 1) or momentary (AV6 Present Value = 2) operation, then  
 BV4 Present Value is set to Read only.

**Binary Value Object** (Present Value defaults to 0 (INACTIVE) for Relay Off. Can be set to 1 (ACTIVE) for Relay On)  
**Relay Enable** (This controls the optional relay, some properties change if the relay is not installed)

Property	Default Value	Property Data Type	Access
Object Identifier	BV5 (Binary Value 5)	BACnetObjectIdentifier	Read
Object Name	Relay Enable	CharacterString (32)	Read
Object Type	BINARY_VALUE (5)	BACnetObjectType	Read
Present Value	INACTIVE (0)	BACnetBinaryPV	Read / Write
Description	Relay Off (0) or Relay On (1)	CharacterString (32)	Read
Status Flags	{ false, false, false, false } (0000) or (1100) if no relay	BACnetStatusFlags	Read
Event State	NORMAL (0) or FAULT (1) if no relay	BACnetEventState	Read
Reliability	NO_FAULT_DETECTED (0) or NO_SENSOR (1)	BACnetReliability	Read
Out of Service	FALSE (0)	Boolean	Read
Property List		BACnetArray	Read

**Binary Value Object Setpoint Mode** (Present Value defaults to 0 (INACTIVE) for Temperature. Can be set to 1 (ACTIVE) for %RH)  
 (If the setpoint option is not installed, the Status Flags, Event State and Reliability properties change)

Property	Default Value	Property Data Type	Access
Object Identifier	BV6 (Binary Value 6)	BACnetObjectIdentifier	Read
Object Name	Setpoint Mode	CharacterString (32)	Read
Object Type	BINARY_VALUE (5)	BACnetObjectType	Read
Present Value	INACTIVE (0)	BACnetBinaryPV	Read / Write
Description	Temperature (0) or %RH (1)	CharacterString (32)	Read
Status Flags	{false, false, false, false} (0000) or (1100) if no setpoint	BACnetStatusFlags	Read
Event State	NORMAL (0) or FAULT (1) if no setpoint	BACnetEventState	Read
Reliability	NO_FAULT_DETECTED (0) or NO_SENSOR (1)	BACnetReliability	Read
Out of Service	FALSE (0)	Boolean	Read
Property List		BACnetArray	Read

\* Notes This object determines if the front panel setpoint controls will be used to control Temperature or Relative Humidity within limits set by the Setpoint Minimum and Setpoint Maximum objects. The Setpoint AI4 object values and LCD display will change depending on the setting.

**Binary Value Object Setpoint Resolution** (Present Value defaults to 0 (INACTIVE) for 1°. Can be set to 1 (ACTIVE) for 0.5°)  
 (If the setpoint option is not installed, the Status Flags, Event State and Reliability properties change)

Property	Default Value	Property Data Type	Access
Object Identifier	BV7 (Binary Value 7)	BACnetObjectIdentifier	Read
Object Name	Setpoint Resolution	CharacterString (32)	Read
Object Type	BINARY_VALUE (5)	BACnetObjectType	Read
Present Value	INACTIVE (0)	BACnetBinaryPV	Read / Write
Description	1 Degree (0) or 0.5 Degree (1)	CharacterString (32)	Read
Status Flags	{false, false, false, false} (0000) or (1100) if no setpoint	BACnetStatusFlags	Read
Event State	NORMAL (0) or FAULT (1) if no setpoint	BACnetEventState	Read
Reliability	NO_FAULT_DETECTED (0) or NO_SENSOR (1)	BACnetReliability	Read
Out of Service	FALSE (0)	Boolean	Read
Property List		BACnetArray	Read

\* Notes The default setpoint resolution is 1°. This applies to the setpoint temperature display and Setpoint object only.  
 For example: The LCD will display 22, 23, 24 °C for the setpoint setting.  
 The resolution can be changed to 0.5° for the setpoint display and value.  
 For example: The LCD will display 22.0, 22.5, 23.0 °C for the setpoint.  
 This setting has no effect on the AI1 (Temperature) object value or temperature display.

**BACnet Trouble-shooting**

This network device operates as a slave. It will not communicate unless a master is connected to the network and sends a request for information, then the slave will answer. If the device does not communicate properly, first check that the communication wires are not reversed. Then check communication parameters set in the menu.

The default BACnet MAC address is 3 and each device must have a unique address to communicate properly. Use the Setup menu to change the MAC address to a unique number for each unit. Ensure the device object name and device object identifier are unique on the entire BACnet network, not just on the MS/TP sub-network. Both of these properties are writable in the device object.

The device automatically selects a device object name for itself using the format STAT\_003, where 003 is the MS/TP MAC address (000 to 127) as set in the menu. If this name is changed by writing to the device Object\_Name property via BACnet, then the MAC number will no longer be appended to the object name.

The device also automatically selects a device object identifier for itself using the format 381xxx, where xxx is the MS/TP MAC address (000 to 127) as set by the menu. If this ID is changed by writing to the device Object\_Identifier property via BACnet, then the MAC number will no longer be appended to the object ID.

The default BACnet baud rate is 9600. Use the Setup menu to change the baud rate to the correct setting.

Ensure the application software (graphical interface) is not set to poll the devices too frequently. For example, if the software is polling the devices every 500 mS, the network could be heavily congested with the network traffic and may not operate reliably. A slower polling rate such as 5 to 10 seconds will usually produce better results on a typical network segment.

Use care when setting the MS/TP MAC address (via the menu) and the device object Max\_Master property since both can have a significant effect on the network efficiency. Some MAC address and Max\_Master combinations will operate more efficiently than others. MAC addresses should be selected sequentially, starting at the lowest possible value.

For example, on a five node segment, the device MAC addresses should be set to 1, 2, 3, 4 and 5. In this case, if the Max\_Master property value is left at the 127 default, then there will be a lot of wasted time on the network polling for masters that are not present. In this example, the five nodes should be set such that Max\_Master is equal to 5. The Max\_Master value initially defaults to 127 so that any master can be found when the device first starts.



**ModBus Protocol**

This section describes the implementation of the Modbus protocol. It is intended to assist control system programmers who may need to add support to their systems to communicate with this device. This device communicates on standard Modbus networks using RTU mode transmission. It operates as a slave device (address from 1 to 255) and expects a Modbus master device to transmit queries, which it will answer.

Only map the registers that are installed and required. Excessive point mapping will lower the network performance. Some registers will not be available if the hardware option is not installed. For example, register 40004 will always read 0 if there is no Fan Speed control installed. This could also be the case if the device has no RH, setpoint or relay options.

**RTU Message Format**

Modbus Framing	8 bit binary
Data Bits	start bits --- 1 data bits --- 8 parity bits --- none, odd or even stop bits --- 1 or 2
Baud Rate	300, 600, 1200, 2400, 4800, 9600 or 19200
Duplex	Half duplex
Error Checking	Cyclical Redundancy Check (CRC) CRC-16 --- polynomial $x^{16}+x^{15}+x^2+x^0$ 0x8005 or reversed version 0xA001 or CRC-CITT --- polynomial $x^{16}+x^{12}+x^5+x^0$ 0x1021 or reversed version 0x8408
Latency	More than 3.5 characters --- minimum, 50, 100, 150, 200, 250, 300 or 350 mS

**RTU Framing Support and Bit Sequences**

Start	1	2	3	4	5	6	7	8	Stop	
Start	1	2	3	4	5	6	7	8	Stop	Stop
Start	1	2	3	4	5	6	7	8	Odd	Stop
Start	1	2	3	4	5	6	7	8	Even	Stop

**Modbus Register Addressing**

Modbus Address	Typical Offset	Units	Data Type	Access	Notes
40001	+0		Word	Read	Unsigned 16-bit integer, DEVICE_STATUS 0x0000 = normal status, 0x0001 = abnormal status
40002	+1	°C/°F	Word	Read	Unsigned 16-bit integer, TEMPERATURE_VALUE x 10 Multiplier = 10 0 to 500 °C, 320 to 1220 °F
40003	+2	%RH	Word	Read	Unsigned 16-bit integer, RELATIVE_HUMIDITY_VALUE 0 to 100
40004	+3		Word	Read	Unsigned 16-bit integer, FAN_SPEED_VALUE Auto=0, Off=1, Low=2, Med=3, High=4
40005	+4	°C/°F %RH	Word	Read	Unsigned 16-bit integer, SETPOINT_VALUE For °C and °F multiplier = 10, ie: 23.5 °C = 235 For %RH multiplier = 1, ie: 60 %RH = 60
40006	+5		Word	Read	Unsigned 16-bit integer, OVERRIDE_STATUS 0 = override not activated, 1 = override activated Note this value is latched when the switch is pressed
40007	+6	°C/°F	Word	Write	Unsigned 16-bit integer, TEMPERATURE_OFFSET = 0 to 0x14 C_OFFSET = TEMPERATURE_OFFSET / 2 - 5 = -5.0 to 5.0 °C F_OFFSET = TEMPERATURE_OFFSET - 10 = -10 to 10 °F
40008	+7	%RH	Word	Write	Unsigned 16-bit integer, RH_OFFSET = 0 to 0x14 RH_OFF = RH_OFFSET - 10 = -10 to 10 %RH
40009	+8	°C/°F %RH	Word	Write	Unsigned 16-bit integer, SETPOINT_MIN See register description 10 to 20 °C or 50 to 68 °F or 10 to 60 %RH
40010	+9	°C/°F %RH	Word	Write	Unsigned 16-bit integer, SETPOINT_MAX See register description 20 to 30 °C or 68 to 86 °F or 30 to 80 %RH
40011	+10		Word	Write	Unsigned 16-bit integer, DISPLAY_MODE = 0 to 0x03 0 = None, 1 = Temp, 2 = RH, 3 = Temp + RH
40012	+11		Word	Write	Unsigned 16-bit integer, TEMPERATURE_UNITS 0 = °C, 1 = °F
40013	+12		Word	Write	Unsigned 16-bit integer, TEMPERATURE_RESOLUTION 0 = 1°, 1 = 0.5° (for LCD display)
40014	+13		Word	Write	Unsigned 16-bit integer, OCC_ENABLE 0 = OCC Off, 1 = OCC On (for LCD display)
40015	+14		Word	Write	Unsigned 16-bit integer, OVERRIDE_RESET write 0 to reset OVERRIDE_STATUS to 0
40016	+15		Word	Write	Unsigned 16-bit integer, RELAY_ENABLE 0 = relay Off, 1 = relay On
40017	+16		Word	Write	Unsigned 16-bit integer, SETPOINT_MODE 0 = temperature, 1 = %RH

40018	+17		Word	Write	Unsigned 16-bit integer, SETPOINT_RESOLUTION 0 = 1°, 1 = 0.5° (for temperature setpoint only)
-------	-----	--	------	-------	--

**RTU Function Codes**

**0x03 --- Read holding registers**

Query

Slave address (0x01 to 0xFF)	Function code (0x03)	Starting address MSB	Starting address LSB	Quantity of registers MSB	Quantity of registers LSB	CRC LSB	CRC MSB
---------------------------------	-------------------------	-------------------------	-------------------------	------------------------------	------------------------------	------------	------------

\* Starting address = 0x0000 to 0xFFFF, Quantity of registers = 0x0000 to 0x007D

Response

Slave address (0x01 to 0xFF)	Function code (0x03)	Byte count 2N	Register value MSB	Register value LSB	...	CRC LSB	CRC MSB
---------------------------------	-------------------------	------------------	-----------------------	-----------------------	-----	------------	------------

\* N= Quantity of registers

**0x06 --- Write single register**

Query

Slave address (0x01 to 0xFF)	Function code 0x06	Register address MSB	Register address LSB	Register value MSB	Register value LSB	CRC LSB	CRC MSB
---------------------------------	-----------------------	-------------------------	-------------------------	-----------------------	-----------------------	------------	------------

Response

Slave address (0x01 to 0xFF)	Function code 0x06	Register address MSB	Register address LSB	Register value MSB	Register value LSB	CRC LSB	CRC MSB
---------------------------------	-----------------------	-------------------------	-------------------------	-----------------------	-----------------------	------------	------------

\* Register address = 0x0000 to 0xFFFF, Registers value = 0x0000 to 0xFFFF

**Exception response**

Slave address (0x01 to 0xFF)	Function code + 0x80	Exception code 0x01, 0x02 or 0x03	CRC LSB	CRC MSB
---------------------------------	-------------------------	--------------------------------------	------------	------------

\* An exception response is only returned if the CRC is correct  
Exception code 01 --- illegal function, 02 --- illegal address, 03 --- illegal data value

The RTU function codes supported are shown below.

**0x03 --- Read DEVICE\_STATUS**

Query

Slave address (0x01 to 0xFF)	0x03	0x00	0x00	0x00	0x01	CRC LSB	CRC MSB
---------------------------------	------	------	------	------	------	------------	------------

Response

Slave address (0x01 to 0xFF)	0x03	0x02	Register value 0x00	Register value LSB	CRC LSB	CRC MSB
---------------------------------	------	------	------------------------	-----------------------	------------	------------

\* Register value = 0x0000 in normal status, 0x0001 in abnormal status

**0x03 --- Read TEMPERATURE\_VALUE**

Query

Slave address (0x01 to 0xFF)	0x03	0x00	0x01	0x00	0x01	CRC LSB	CRC MSB
---------------------------------	------	------	------	------	------	------------	------------

Response

Slave address (0x01 to 0xFF)	0x03	0x02	Register value MSB	Register value LSB	CRC LSB	CRC MSB
---------------------------------	------	------	-----------------------	-----------------------	------------	------------

\* Register value = 0x0000 to 0x01F4, corresponding to 0 to 50.0 °C (multiplier = 10)  
 or = 0x0140 to 0x04C4, corresponding to 32.0 to 122.0 °F (multiplier = 10)

The temperature value is either in °C (default) or °F depending on the value of the TEMPERATURE\_UNITS register. This register has a multiplier of 10, the application must divide by 10 to obtain the correct value.

**0x03 --- Read RELATIVE\_HUMIDITY\_VALUE**

Query

Slave address (0x01 to 0xFF)	0x03	0x00	0x02	0x00	0x01	CRC LSB	CRC MSB
---------------------------------	------	------	------	------	------	------------	------------

Response

Slave address (0x01 to 0xFF)	0x03	0x02	Register value MSB	Register value LSB	CRC LSB	CRC MSB
---------------------------------	------	------	-----------------------	-----------------------	------------	------------

\* Register value = 0x0000 to 0x0064, corresponding to 0 to 100 %RH (multiplier = 1)

The register will always read 0x0000 if the Relative Humidity option is not installed.

**0x03 --- Read FAN\_SPEED\_VALUE**

Query

Slave address (0x01 to 0xFF)	0x03	0x00	0x03	0x00	0x01	CRC LSB	CRC MSB
---------------------------------	------	------	------	------	------	------------	------------

Response

Slave address (0x01 to 0xFF)	0x03	0x02	Register value MSB	Register value LSB	CRC LSB	CRC MSB
---------------------------------	------	------	-----------------------	-----------------------	------------	------------

- \* Register value = 0x0000 corresponding to the AUTO switch setting,
- = 0x0001 corresponding to the OFF switch setting,
- = 0x0002 corresponding to the LOW switch setting,
- = 0x0003 corresponding to the MED switch setting,
- = 0x0004 corresponding to the HIGH switch setting.

The register will always read 0x0000 if the Fan Speed option is not installed.

**0x03 --- Read SETPOINT\_VALUE**

Query

Slave address (0x01 to 0xFF)	0x03	0x00	0x04	0x00	0x01	CRC LSB	CRC MSB
---------------------------------	------	------	------	------	------	------------	------------

Response

Slave address (0x01 to 0xFF)	0x03	0x02	Register value MSB	Register value LSB	CRC LSB	CRC MSB
---------------------------------	------	------	-----------------------	-----------------------	------------	------------

- \* The setpoint may be configured in various ways as required by the application.

The setpoint may be set to control either temperature or RH using the SETPOINT\_MODE register.

For temperature, Register value = 0x0064 to 0x012C, corresponding to 10.0 to 30.0 °C (multiplier = 10)  
   or           = 0x01F4 to 0x035C, corresponding to 50.0 to 86.0 °F (multiplier = 10)

For RH,                   Register value = 0x000A to 0x0050, corresponding to 10 to 80 %RH (multiplier = 1)

If SETPOINT\_MODE is set to temperature, then the SETPOINT\_VALUE units will be the same as the TEMPERATURE\_UNITS, either °C or °F.

The SETPOINT\_VALUE is limited by the SETPOINT\_MIN and SETPOINT\_MAX registers. When the setpoint is adjusted with the front panel UP/DOWN switches, it cannot go below SETPOINT\_MIN or above SETPOINT\_MAX.

The SETPOINT\_VALUE must step according to the setting of the SETPOINT\_RESOLUTION register, either in 1° or 0.5° steps. When the setpoint is adjusted with the front panel UP/DOWN switches, it will step by either 1° or 0.5°.

The register will always read 0x0000 if the Setpoint option is not installed.

**0x03 --- Read *OVERRIDE\_STATUS***

Query

Slave address (0x01 to 0xFF)	0x03	0x00	0x05	0x00	0x01	CRC LSB	CRC MSB
---------------------------------	------	------	------	------	------	------------	------------

Response

Slave address (0x01 to 0xFF)	0x03	0x02	Register value 0x00	Register value LSB	CRC LSB	CRC MSB
---------------------------------	------	------	------------------------	-----------------------	------------	------------

\* Register value = 0x0000 override not pressed, 0x0001 override has been pressed.  
The register will always read 0x0000 if the override option is not installed.

**0x06 --- Write *TEMPERATURE\_OFFSET***

Query

Slave address (0x01 to 0xFF)	0x06	0x00	0x06	0x00	Register value LSB	CRC LSB	CRC MSB
---------------------------------	------	------	------	------	-----------------------	------------	------------

Response

Slave address (0x01 to 0xFF)	0x06	0x00	0x06	0x00	Register value LSB	CRC LSB	CRC MSB
---------------------------------	------	------	------	------	-----------------------	------------	------------

\* This register is used to add or subtract an offset to the temperature value if necessary to conform to a local reference.

Register value = 0x0000 to 0x0014

For °C operation, this corresponds to  $T\_OFFSET / 2 - 5 = -5.0$  to  $5.0$  °C. ie: 0x0003 =>  $3/2 - 5 = -3.5$  °C offset.

For °F operation, this corresponds to  $T\_OFFSET - 10 = -10$  to  $10$  °F. ie: 0x0003 =>  $3 - 10 = -7$  °F offset.

The operating temperature units (°C or °F) for the device should be selected first, and then add any offset if necessary.

**0x06 --- Write *RH\_OFFSET***

Query

Slave address (0x01 to 0xFF)	0x06	0x00	0x07	0x00	Register value LSB	CRC LSB	CRC MSB
---------------------------------	------	------	------	------	-----------------------	------------	------------

Response

Slave address (0x01 to 0xFF)	0x06	0x00	0x07	0x00	Register value LSB	CRC LSB	CRC MSB
---------------------------------	------	------	------	------	-----------------------	------------	------------

\* This register is used to add or subtract an offset to the RH value if necessary to conform to a local reference.

Register value = 0x0000 to 0x0014, corresponding to  $RH\_OFFSET - 10 = -10$  to  $10$  %RH.

ie: 0x0003 =>  $3 - 10 = -7$  %RH offset.

The value of this register will have no effect if the Relative Humidity option is not installed.

**0x06 --- Write SETPOINT\_MIN**

Query

Slave address (0x01 to 0xFF)	0x06	0x00	0x08	0x00	Register value LSB	CRC LSB	CRC MSB
---------------------------------	------	------	------	------	-----------------------	------------	------------

Response

Slave address (0x01 to 0xFF)	0x06	0x00	0x08	0x00	Register value LSB	CRC LSB	CRC MSB
---------------------------------	------	------	------	------	-----------------------	------------	------------

\* This register sets the minimum value of adjustment for the Setpoint option.

The setpoint may be set to control either temperature or RH using the SETPOINT\_MODE register.

For temperature, Register value = 0x0064 to 0x00C8, corresponding to 10.0 to 20.0 °C (multiplier = 10)  
 or = 0x01F4 to 0x02A8, corresponding to 50.0 to 68.0 °F (multiplier = 10)  
 For RH, Register value = 0x000A to 0x003C, corresponding to 10 to 60 %RH (multiplier = 1)

If SETPOINT\_MODE is set to temperature, then the SETPOINT\_VALUE units will be the same as the TEMPERATURE\_UNITS, either °C or °F.

The SETPOINT\_VALUE is limited by the SETPOINT\_MIN and SETPOINT\_MAX registers. When the setpoint is adjusted with the front panel UP/DOWN switches, it cannot go below SETPOINT\_MIN or above SETPOINT\_MAX.

The SETPOINT\_VALUE must step according to the setting of the SETPOINT\_RESOLUTION register, either in 1° or 0.5° steps. When the setpoint is adjusted with the front panel UP/DOWN switches, it will step by either 1° or 0.5°.

The register will have no effect if the Setpoint option is not installed.

**0x06 --- Write SETPOINT\_MAX**

Query

Slave address (0x01 to 0xFF)	0x06	0x00	0x09	0x00	Register value LSB	CRC LSB	CRC MSB
---------------------------------	------	------	------	------	-----------------------	------------	------------

Response

Slave address (0x01 to 0xFF)	0x06	0x00	0x09	0x00	Register value LSB	CRC LSB	CRC MSB
---------------------------------	------	------	------	------	-----------------------	------------	------------

\* This register sets the maximum value of adjustment for the Setpoint option.

The setpoint may be set to control either temperature or RH using the SETPOINT\_MODE register.

For temperature, Register value = 0x00C8 to 0x012C, corresponding to 20.0 to 30.0 °C (multiplier = 10)  
 or = 0x02A8 to 0x035C, corresponding to 68.0 to 86.0 °F (multiplier = 10)  
 For RH, Register value = 0x001E to 0x0050, corresponding to 30 to 80 %RH (multiplier = 1)

Conditions and operation are the same as for SETPOINT\_MIN.

The register will have no effect if the Setpoint option is not installed.

**0x06 --- Write DISPLAY\_MODE**

Query

Slave address (0x01 to 0xFF)	0x06	0x00	0x0A	0x00	Register value LSB	CRC LSB	CRC MSB
---------------------------------	------	------	------	------	-----------------------	------------	------------

Response

Slave address (0x01 to 0xFF)	0x06	0x00	0x0A	0x00	Register value LSB	CRC LSB	CRC MSB
---------------------------------	------	------	------	------	-----------------------	------------	------------

- \* Register value = 0x0000 = no display, no backlight (except for menu operation)
- = 0x0001 = temperature value only is displayed
- = 0x0002 = RH value only is displayed
- = 0x0003 = temperature and RH values toggle every 5 seconds

A temperature only device will not have options 2 or 3 (the default = 1).

A temperature plus RH device has default = 3.

**0x06 --- Write TEMPERATURE\_UNITS**

Query

Slave address (0x01 to 0xFF)	0x06	0x00	0x0B	0x00	Register value LSB	CRC LSB	CRC MSB
---------------------------------	------	------	------	------	-----------------------	------------	------------

Response

Slave address (0x01 to 0xFF)	0x06	0x00	0x0B	0x00	Register value LSB	CRC LSB	CRC MSB
---------------------------------	------	------	------	------	-----------------------	------------	------------

- \* Register value = 0x0000 = sets the device to °C operation
- = 0x0001 = sets the device to °F operation

**0x06 --- Write TEMPERATURE\_RESOLUTION**

Query

Slave address (0x01 to 0xFF)	0x06	0x00	0x0C	0x00	Register value LSB	CRC LSB	CRC MSB
---------------------------------	------	------	------	------	-----------------------	------------	------------

Response

Slave address (0x01 to 0xFF)	0x06	0x00	0x0C	0x00	Register value LSB	CRC LSB	CRC MSB
---------------------------------	------	------	------	------	-----------------------	------------	------------

- \* Register value = 0x0000 = sets the LCD display temperature resolution to 1° (ie: 23 °C)
- = 0x0001 = sets the LCD display temperature resolution to 0.5° (ie: 23.5 °C)

**0x06 --- Write OCC\_ENABLE**

Query

Slave address (0x01 to 0xFF)	0x06	0x00	0x0D	0x00	Register value LSB	CRC LSB	CRC MSB
---------------------------------	------	------	------	------	-----------------------	------------	------------

Response

Slave address (0x01 to 0xFF)	0x06	0x00	0x0D	0x00	Register value LSB	CRC LSB	CRC MSB
---------------------------------	------	------	------	------	-----------------------	------------	------------

- \* Register value = 0x0000 = turns the LCD OCC symbol off , = 0x0001 = turns the LCD OCC symbol on



**0x06 --- Write *OVERRIDE\_RESET***

Query

Slave address (0x01 to 0xFF)	0x06	0x00	0x0E	0x00	Register value LSB	CRC LSB	CRC MSB
---------------------------------	------	------	------	------	-----------------------	------------	------------

Response

Slave address (0x01 to 0xFF)	0x06	0x00	0x0E	0x00	Register value LSB	CRC LSB	CRC MSB
---------------------------------	------	------	------	------	-----------------------	------------	------------

\* If the *OVERRIDE\_STATUS* has been activated, write 0x0000 to this register to reset it back to 0x0000.

The register will have no effect if the Override option is not installed.

**0x06 --- Write *RELAY\_ENABLE***

Query

Slave address (0x01 to 0xFF)	0x06	0x00	0x0F	0x00	Register value LSB	CRC LSB	CRC MSB
---------------------------------	------	------	------	------	-----------------------	------------	------------

Response

Slave address (0x01 to 0xFF)	0x06	0x00	0x0F	0x00	Register value LSB	CRC LSB	CRC MSB
---------------------------------	------	------	------	------	-----------------------	------------	------------

\* Register value = 0x0000 = turns the relay off  
 = 0x0001 = turns the relay on

The register will have no effect if the Relay option is not installed.

**0x06 --- Write *SETPOINT\_MODE***

Query

Slave address (0x01 to 0xFF)	0x06	0x00	0x10	0x00	Register value LSB	CRC LSB	CRC MSB
---------------------------------	------	------	------	------	-----------------------	------------	------------

Response

Slave address (0x01 to 0xFF)	0x06	0x00	0x10	0x00	Register value LSB	CRC LSB	CRC MSB
---------------------------------	------	------	------	------	-----------------------	------------	------------

\* Register value = 0x0000 = sets the setpoint mode to temperature  
 = 0x0001 = sets the setpoint mode to %RH

The register will have no effect if the Setpoint option is not installed.

**0x06 --- Write SETPOINT\_RESOLUTION**

Query

Slave address (0x01 to 0xFF)	0x06	0x00	0x11	0x00	Register value LSB	CRC LSB	CRC MSB
---------------------------------	------	------	------	------	-----------------------	------------	------------

Response

Slave address (0x01 to 0xFF)	0x06	0x00	0x11	0x00	Register value LSB	CRC LSB	CRC MSB
---------------------------------	------	------	------	------	-----------------------	------------	------------

- \* Register value = 0x0000 = sets the temperature setpoint resolution to 1° (ie: 23 °C)
- = 0x0001 = sets the temperature setpoint resolution to 0.5° (ie: 23.5 °C)

This setting has no effect if the SETPOINT\_MODE is set to %RH.

The register will have no effect if the Setpoint option is not installed.

**Exception response**

Slave address (0x01 to 0xFF)	Function code + 0x80	Exception code * 0x01, 0x02 or 0x03	CRC LSB	CRC MSB
---------------------------------	-------------------------	--	------------	------------

- \* An exception response is only returned if the CRC is correct
- Exception code 01 --- illegal function
- Exception code 02 --- illegal address
- Exception code 03 --- illegal data value

**Modbus Trouble-shooting**

The device operates as a slave. It will not communicate unless a master is connected to the network and sends a request for information, then the slave will answer. If the device does not communicate properly, first check that the communication wires are not reversed. Then check the communication parameters in the menu in the following sequence: Network address, baud rate, parity bit, stop bit, CRC polynomial and slave response delay.

The factory default Modbus address is 03 and each device must have its unique address to communicate properly on the bus. Use the menu to change the Slave address to a unique number for each unit.

The default Modbus baud rate is 9600. Use the menu to change the baud rate to the correct setting.

The default Modbus parity is None. If this is not correct, use the menu to change the parity from None to Odd or Even.

The default stop bits is 1. Use the menu to change the stop bit setting to 2. For some configurations the value is fixed.

The default Modbus CRC value is A001. The menu can be used to change this setting. It is the CRC polynomial setting and can be changed between A001, 1021, 8005 or 8408.

The default Modbus delay is minimum (0). This can be changed in the menu. It is the slave response delay and can be set from minimum to 350ms. For example, the minimum delay means 3.5 character time delays or 4ms for 9600 baud rate.

**General Specifications**

Power Supply . . . . . 20 – 28 Vac/dc (non-isolated half-wave rectified)  
 Consumption . . . . . 35 mA max @ 24 Vdc  
 Protection Circuitry . . . . . Reverse voltage protected, overvoltage protected  
 Operating Conditions . . . . . 32-122 °F (0-50 °C), 0-95 %RH non-condensing  
 Wiring Connections . . . . . Screw terminal block (14 to 22 AWG)  
 Enclosure . . . . . Wall mount enclosure, 3.3”w x 4.7”h x 1.15”d (84 x 119 x 29 mm)

**Temperature**

Sensing Element . . . . . 10K thermistor, ± 0.4 °F (± 0.2 °C)  
 Range . . . . . 32-122 °F (0-50 °C)

**Interface**

Hardware . . . . . 2-wire RS-485  
 Software . . . . . Native BACnet or ModBus MS/TP protocol  
 Baud Rate . . . . . Locally set from 300 - 76800  
 Network Address Range . . . . . Locally set to 0-127 for BACnet, 1-255 for ModBus (factory default is 3)  
 (63 devices max on one daisy chain)

**LCD Display**

Resolution . . . . . 0.5°/1°C or 0.5°/1° F (selectable), 1 %RH  
 Size . . . . . 1.5” w x 0.65” h (38.1 x 16.5 mm) 3 digit  
 Backlight . . . . . Auto-dimming, enable or disable via jumper

**Optional RH Signal**

Sensor . . . . . Thermoset polymer based capacitive  
 Accuracy . . . . . ± 2 %RH  
 Range . . . . . 0-100 %RH, non-condensing  
 Resolution . . . . . 1 %RH  
 Hysteresis . . . . . ± 3 %RH  
 Response Time . . . . . 15 seconds typical  
 Stability . . . . . ± 1.2 %RH typical @ 50 %RH in 5 years

**Optional Relay Output**

Contact Ratings . . . . . Form A contact (N.O.), 2 Amps @ 140 Vac, 2 Amps @ 30 Vdc  
 Relay Control . . . . . Via BACnet or ModBus

**Optional Override Switch** . . Front panel push-button available via BACnet or ModBus

**Optional Setpoint Control** . . Front panel push-buttons available via BACnet or ModBus

**Optional Fan Speed Switch** . Off, Auto, Low, Medium, High via BACnet or ModBus

**BACnet Protocol Implementation Conformance Statement (PICS)**

**Date :** March 30, 2016  
**Vendor Name :** Greystone Energy Systems Inc.  
**Product Name :** RH/T Network Sensor  
**Product Model Number :** NTRC Series  
**Application Software Version :** 1.2  
**Firmware Revision :** 1.4  
**BACnet Protocol Revision :** 14

**Product Description :** The Greystone RH/T Network Sensor is a smart room sensor with native BACnet MS/TP protocol for network communication. It measures room temperature levels and reports this value back to a building automation system (BAS). The device may also be configured with a relative humidity (RH) sensor to measure room %RH, a setpoint control, an override switch, an alarm relay output and a fan speed switch.

**BACnet Standardized Device Profile (Annex L) :** BACnet Application Specific Controller (B-ASC)

**BACnet Interoperability Building Blocks Supported (Annex K) :** DS-RP-B, DS-WP-B, DM-DDB-B, DM-DOB-B, DM-DCC-B

**Segmentation Capability :** Not supported

**Standard Object Types Supported :**

Object Type	Dynamically Creatable	Dynamically Deletable	Optional Properties Supported	Writable Properties
Device	No	No	Location, Description, Max_Master, Max_Info_Frames	Object_Identifier, Object_Name, Location, Description, APDU_Timeout, Max_Master, Number_Of_APDU_Retries
Analog Input	No	No	Description, Reliability, Device_Type	
Analog Value	No	No	Description	Present_Value
Binary Value	No	No	Description, Reliability	Present_Value

**Data Link Layer Options :** MS/TP master (Clause 9), baud rates : 9600, 19200, 38400, 76800

**Device Address Binding :** Not supported

**Networking Options :** None

**Character Set Supported :** ISO 10646 (UTF-8)