

#### INTRODUCTION

The high accuracy outside temperature transmitter incorporates a precision platinum RTD in a weatherproof enclosure with a sun and wind shield to monitor outside temperature levels. A transmitter that provides a high accuracy signal with excellent long term stability, low hysteresis and fast response is available with various ranges. A compact ABS enclosure with a hinged and gasketed cover is provided for ease of installation.

#### BEFORE INSTALLATION

Read these instructions carefully before installing and commissioning the temperature. Failure to follow these instructions may result in product damage. Do not use in an explosive or hazardous environment, with combustible or flammable gases, as a safety or emergency stop device or in any other application where failure of the product could result in personal injury. **Do not exceed the device ratings.**

#### MOUNTING

Select a suitable mounting spot on an exterior wall where the temperature sensor is best protected from direct exposure to sunlight, wind, etc. preferably on a north facing wall. Do not mount the sensor near opening windows, supply/exhaust air louvres or other known air disturbances. Avoid areas where the sensor is exposed to vibrations or rapid temperature changes.

The temperature sensor provides a connection hole for 1/2" conduit. Run a length of conduit through exterior wall and seal. Use 14-22 AWG shielded wiring for all connections and do not locate the device wires in the same conduit with wiring used to supply inductive loads such as motors. Make all connections in accordance with national and local codes.

The temperature sensor installs directly on an exterior wall using the two integrated mounting holes provided on the enclosure. Select the best mounting technique based on the exterior wall material. The two mounting holes are suitable for a #10 size screw (not supplied). The sensor fitting must be pointing down. See Figure 1.

The enclosure has a hinged cover with a latch. Open the cover by pulling slightly on the latch on the right side of the enclosure. At the same time pulling on the cover, as illustrated in Figure 2.

Feed conduit through the provided hole in the back of the enclosure and secure with a lock nut as shown in Figure 3. It is recommended that weatherproof conduit or cable gland fittings be used.

Make wiring connections as per the "wiring" illustrations on Page 2.

Swing door closed until securely latched. For added security, two screws are provided that may be installed in the integrated screw tabs. See Figure 4.

Figure 1

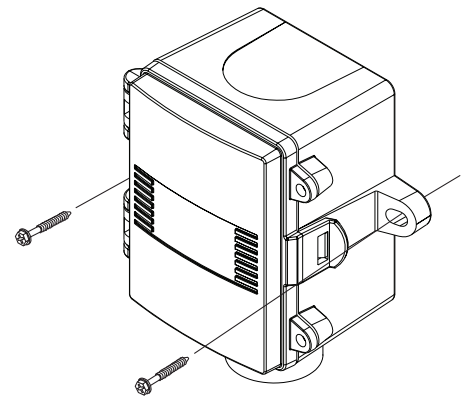

Figure 2

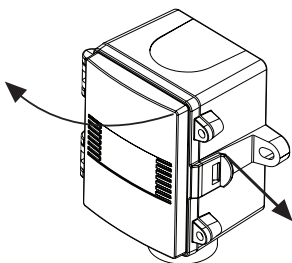

Figure 3

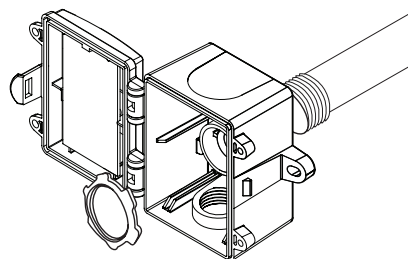
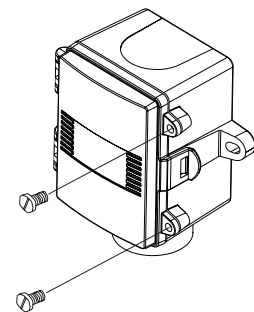
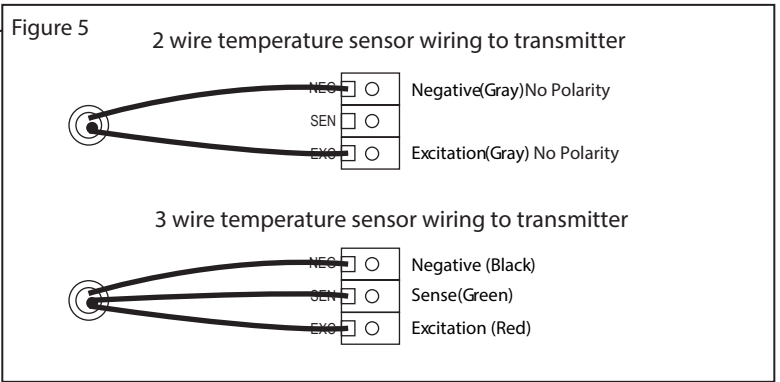
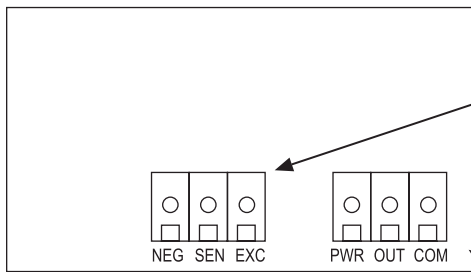

Figure 4



## WIRING

- Deactivate the 24 Vac/dc power supply until all connections are made to the device to prevent equipment damage.
- Use 14-22 AWG shielded wiring for all connections and do not locate the device wires in the same conduit with wiring used to supply inductive loads such as motors. Make all connections in accordance with national and local codes.
- The temperature transmitter comes with the temperature sensor pre-wired to the transmitter board. If removal is required for installation then it may be re-wired as shown in Figure 5.
- Pull at least six inches of control wire into the enclosure, then complete the wiring connection according to the wire diagram for the applicable power supply and output signal type as shown in Figure 6.
- Connect the DC positive or the AC voltage hot side to the PWR terminal. For voltage output or AC power, the supply Common is connected to the COM terminal. The device is reverse voltage protected and will not operate if connected backwards. It has a half-wave power supply so the supply Common is the same as the signal Common. See Figure 6.
- The analog output is available on the OUT terminal. Check the controller Analog Input to determine the proper connection before applying power as shown in Figure 6.
- Once all connections are made and checked, power can be applied.



## SPECIFICATIONS:

Sensor:	1000 ohm platinum RTD
Sensor Accuracy:	RTD Class A: $\pm 0.15^{\circ}\text{C}$ @ $0^{\circ}\text{C}$ RTD 1/3 DIN: $\pm 0.1^{\circ}\text{C}$ @ $0^{\circ}\text{C}$ RTD 1/10 DIN: $\pm 0.03^{\circ}\text{C}$ @ $0^{\circ}\text{C}$
Probe Sensing Range:	-40 to $50^{\circ}\text{C}$ (-2 to $122^{\circ}\text{F}$ ) @ $0^{\circ}\text{C}$ ( $32^{\circ}\text{F}$ )
Wire Material:	PVC insulated, parallel bonded, 22 AWG
Temperature Range:	$\pm 0.2^{\circ}\text{C}$ ( $\pm 0.36^{\circ}\text{F}$ ), 0 to $70^{\circ}\text{C}$ (32 to $158^{\circ}\text{F}$ )
Output Signal:	4-20 mA current loop, 0-5 vdc, or 0-10 Vdc (factory configured)
Transmitter Accuracy:	$\pm 0.125\%$ of span, including linearity
4-20 mA loop power supply:	15-35 Vdc or 22-32 Vac
Minimum Loop Current:	2 mA nominal (occurs with shorted sensor)
Maximum Loop Current:	22.5 mA nominal (occurs with open sensor)
Maximum Loop Load:	>600 ohms
0-5 Vdc Power Supply:	10-35 Vdc or 10-32 Vac
0-10 Vdc Power Supply:	15-35 Vdc or 15-32 Vac
Maximum Current (Voltage):	5 mA nominal
Maximum Output (Voltage):	Limited to <math>5.5\text{ Vdc}</math> for 0-5 Vdc, <math>10.5\text{ Vdc}</math> for 0-10 Vdc
Input Voltage Effect:	Negligible over specified operating range
Projection Circuitry:	Reverse voltage protected and output limited
Ambient Operating Range:	-40 to $50^{\circ}\text{C}$ (-40 to $122^{\circ}\text{F}$ ), 0-95 %RH non-condensing
Enclosure:	ABS - UL94-V0, IP65 (NEMA 4X)
Wiring Connections:	Screw terminal block (14 to 22 AWG)
Country of Origin:	Canada

\*This product is factory calibrated an any field adjustment will void the warranty.

## DIMENSIONS

