

### INTRODUCTION

The high accuracy single point strap-on temperature sensor utilizes a precision sensor that is attached to a 38 mm x 38 mm (1.5" x 1.5") aluminum plate and adhered to a 38 mm x 25.4 mm (1.5 x 1") compressible foam. A 254 mm (10") S/S Pipe clamp is provided to secure the assembly to various sizes of pipe. All probes are constructed to provide excellent heat transfer, fast response, and are potted to resist moisture penetration. A compact ABS enclosure with a hinged and gasketed cover is provided for ease of installation.

### BEFORE INSTALLATION

Read these instructions carefully before installing and commissioning the temperature sensor. Failure to follow these instructions may result in product damage. Do not use in an explosive or hazardous environment, with combustible or flammable gases, as a safety or emergency stop device or in any other application where failure of the product could result in personal injury. **Do not exceed the device ratings.**

### MOUNTING

The strap-on sensor installs directly onto any pipe where space between immersion and sensor with thermowell can't be installed.

Once a suitable spot is selected, remove a small block of insulation, if present. It is recommended that thermal compound be used to improve heat transfer. Spread a liberal amount on the pipe. Open the worm gear clamp by swiveling the worm gear away from the clamp and pull the clamp apart, as shown in Figure 1.

Place the sensor plate on the selected mounting area and wrap clamp around the pipe. Re-insert clamp under the worm gear and pull until snug. Lock in place by swiveling the worm gear towards the clamp. Tighten worm gear clamp by using a standard screw driver or hex nut driver as shown in Figure 2.

The enclosure has a hinged cover with a latch. Open the cover by pulling slightly on the latch on the right side of the enclosure. At the same time pulling on the cover, as illustrated in Figure 3.

A 1/2" NPT threaded connection hole is provided in the bottom of the enclosure. Screw the EMT connector or cable gland connector in until tight. See Figure 4. It is recommended that weatherproof conduit or cable gland fittings be used. E style enclosure includes 1/2" NPT to M16 thread adapter and cable gland fitting.

Make wiring connections as per the "Wiring" illustrations on Page 2.

Swing door closed until securely latched. For added security, 2 screws are provided that may be installed in the integrated screw tabs. See Figure 5.

Figure 1

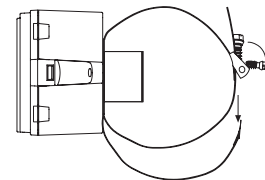

Figure 2

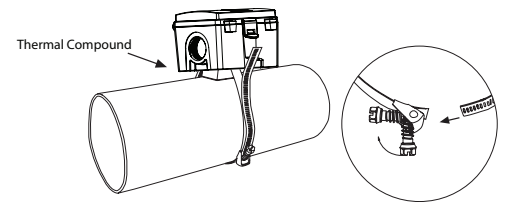

Figure 3

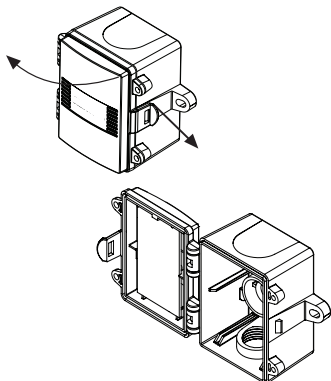

Figure 4

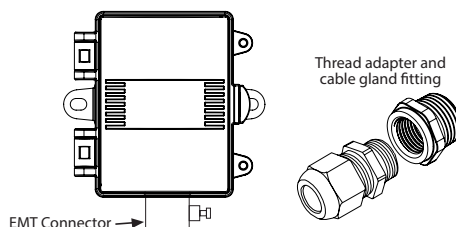
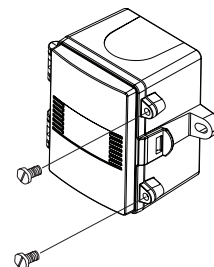
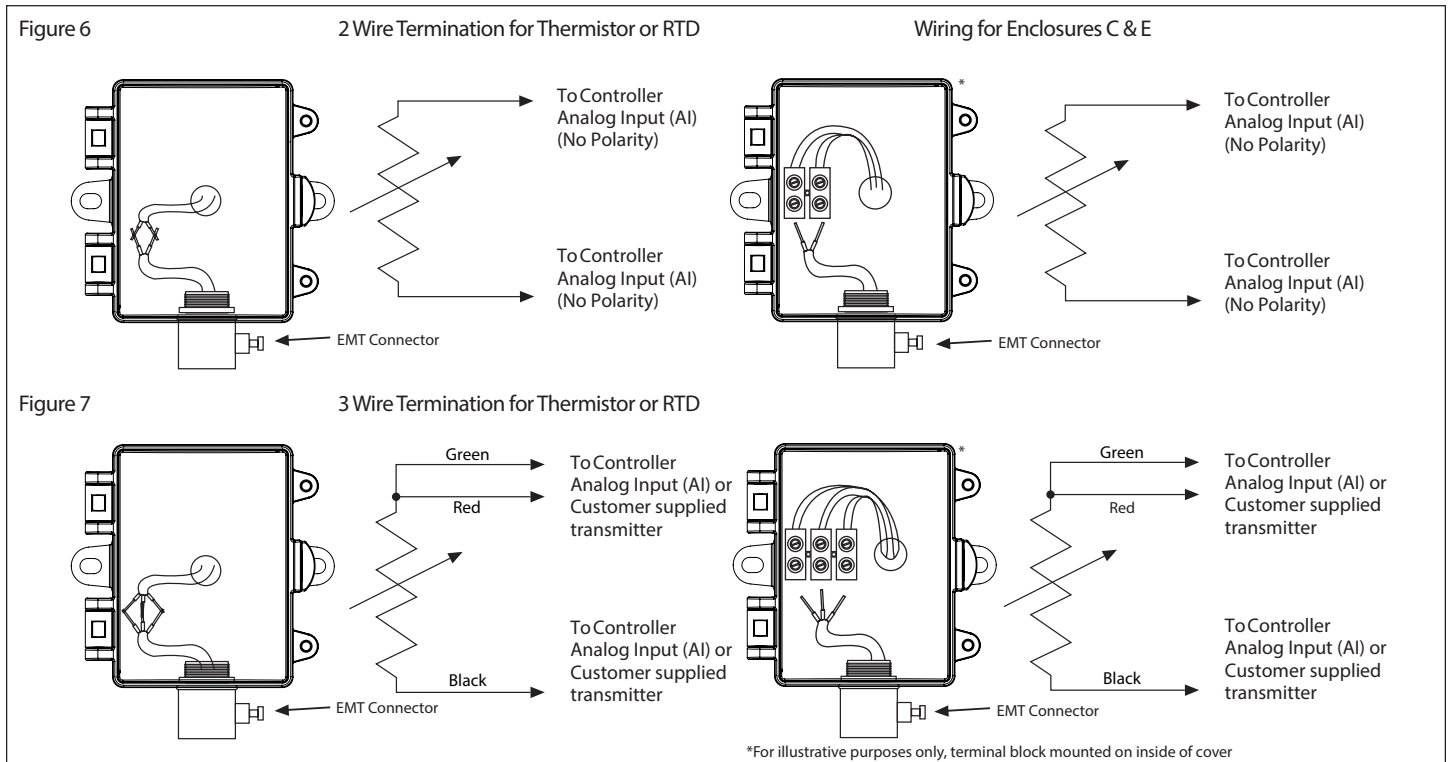

Figure 5



# WIRING

- Use 18 - 24 AWG shielded wiring for all connections. Do not locate the device wires in the same conduit with wiring used to supply inductive loads such as motors. Make all connections in accordance with national and local codes.
- Pull at least six inches of wire into the enclosure, then complete the wiring connection according to wiring diagrams below.
- All thermistors and most RTD's are a two wire hook up and are not polarity sensitive. See Figure 6.
- For RTD's that are three wire see Figure 7.



## TYPICAL WIRE RESISTANCE VALUES

When using low resistance sensors, long wire runs can add significant error to the readings. Use the following chart to determine errors due to wire resistance or consider using a 1000 ohm sensor or a transmitter for better accuracy. Locate the type of wire being used. Multiply the total length of the wire (distance from the controller to the sensor and back) by the number found in the chart below for total resistance.

GAUGE WIRE TYPE	18 AWG	22 AWG	24 AWG
STRANDED (OHMS/FOOT)	5.85 mΩ	14.75 mΩ	23.29 mΩ
SOLID (OHMS/FOOT)	6.4 mΩ	15.85 mΩ	25.72 mΩ

## DIMENSIONS

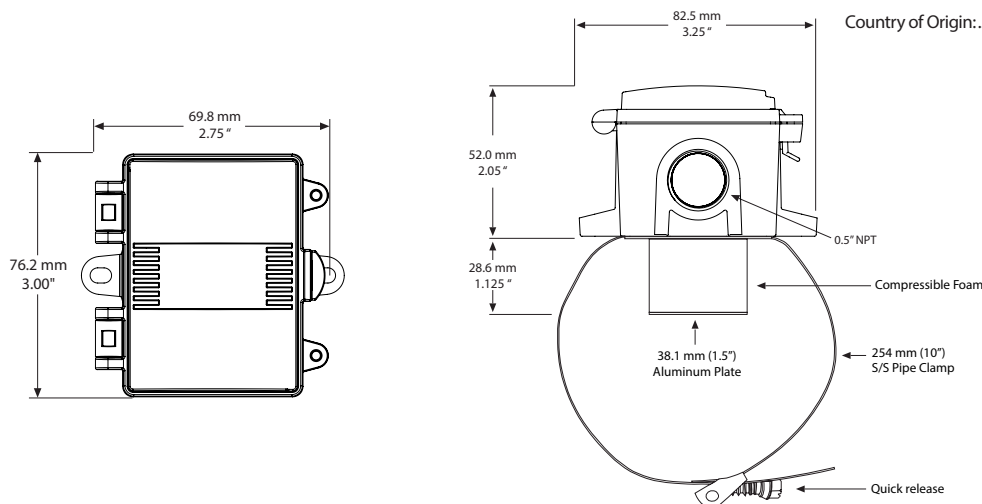

## SPECIFICATIONS:

Sensor Type:..... Various thermistors or RTD  
 Sensor Accuracy:..... **RTD Class A:** ±0.15°C @ 0°C  
   **RTD 1/3 DIN:** ±0.1°C @ 0°C  
   **RTD 1/10 DIN:** ±0.03°C @ 0°C  
   **NTC Thermistor Type 39:** ±0.05°C, 0 to 70°C  
   **NTC Thermistor Type 55:** ±0.03°C, 0 to 70°C  
   **NTC Thermistor Type 40/46:** ±0.1°C, 0 to 70°C  
 Probe Material:..... Aluminum plate with compressible foam backing  
 Probe Sensing Range:..... -20 to 105°C (-4 to 221°F)  
 Ambient Operating Range:..... -40 to 50°C (-40 to 122°F)  
 Probe Size:..... 38 mm (1.5") square  
 Wire Material:..... PVC insulated, parallel bonded, 22 AWG  
 Enclosure:..... ABS - UL94-V0, IP65 (NEMA4X)  
   C - includes terminal block  
   E - includes thread adapter (1/2" NPT to M16), cable gland fitting, and terminal block  
 Termination:..... A - pigtail, 2 or 3 wire  
   C & E - terminal block, 2 or 3 wire  
 Country of Origin:..... Canada

PRINTED IN CANADA