

INTRODUCTION

The high accuracy single point flying lead temperature sensor utilizes a precision sensor that is encapsulated in a 50 mm (2") long x 6 mm (0.236") diameter OD, 304 series stainless steel probe and is provide with 3.05 m (10') of plenum rated FT-6 cable. All probes provide excellent heat transfer, fast response and resistance to moisture penetration.

BEFORE INSTALLATION

Read these instructions carefully before installing and commissioning the temperature sensor. Failure to follow these instructions may result in product damage. Do not use in an explosive or hazardous environment, with combustible or flammable gases, as a safety or emergency stop device or in any other application where failure of the product could result in personal injury. **Do not exceed the device ratings.**

MOUNTING (DUCT)

The flying lead sensor can be used in several different types of applications where single point temperature monitoring is required.

Listed below are some typical applications

The flying lead sensor can be installed directly into any air duct. Select a suitable installation area in the middle of the duct. To achieve the best reading, do not place in an area where air stratification may be present. Avoid areas where the sensor is exposed to vibrations or rapid temperature changes.

Once a suitable spot is selected, drill a 3/8" hole in the top of the duct and slide the probe through, mount a length of flexible duct hanger from top to bottom of the duct. Mount the probe to the duct hanger using a tube clamp or wire tie. See Figure 1.

The flying lead could also be used to measure pipe temperature. Select a suitable spot along the pipe, remove a small section of insulation if present and set aside. It is recommended that thermal compound be used to improve heat transfer. Spread a liberal amount on the pipe. Lay the probe in thermal compound and secure sensor to pipe using a worm gear clamp (not included).

For added protection it is recommended to wrap the probe cable around the pipe 1 to 2 times. Re-install insulation if present, allowing sensor cable to protrude. See Figure 2.

Figure 1

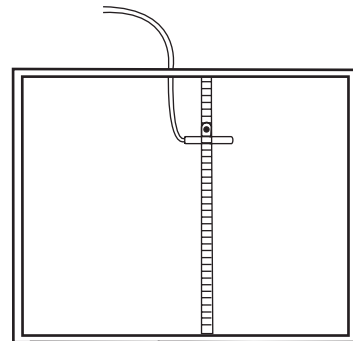
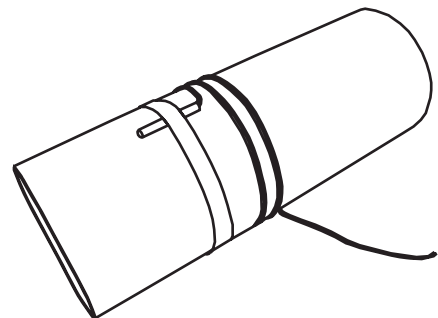

Figure 2



WIRING

- Use 18-24 AWG shielded wiring for all connections. Do not locate the device wires in the same conduit with wiring used to supply inductive loads such as motors. Make all connections in accordance with national and local codes.
- Pull at least six inches of wire into the enclosure, then complete the wiring connection according to the wiring diagrams below.
- All thermistors and most RTD's are a two wire hook up and are not polarity sensitive. See Figure 3.
- For RTD's that are 3 wire connection see Figure 4.

TYPICAL WIRE RESISTANCE VALUES

When using low resistance sensors, long wire runs can add significant error to the readings. Use the following chart to determine errors due to wire resistance or consider using a 1000 ohm sensor or a transmitter for better accuracy. Locate the type of wire being used. Multiply the total length of the wire (distance from the controller to the sensor and back) by the number found in the chart below for total resistance.

GAUGE WIRE TYPE	18 AWG	22 AWG	24 AWG
STRANDED (OHMS/FOOT)	5.85 mΩ	14.75 mΩ	23.29 mΩ
SOLID (OHMS/FOOT)	6.4 mΩ	15.85 mΩ	25.72 mΩ

SPECIFICATIONS:

Sensor Type:..... Various thermistors or RTD

Sensor Accuracy:..... **RTD Class A:** $\pm 0.1^{\circ}\text{C}$ @ 0°C

RTD 1/3 DIN: $\pm 0.1^{\circ}\text{C}$ @ 0°C

RTD 1/10 DIN: $\pm 0.03^{\circ}\text{C}$ @ 0°C

NTC Thermistor Type 39: $\pm 0.05^{\circ}\text{C}$, 0 to 70°C

NTC Thermistor Type 55: $\pm 0.03^{\circ}\text{C}$, 0 to 70°C

NTC Thermistor Type 40/46: $\pm 0.1^{\circ}\text{C}$, 0 to 70°C

Temperature Range:..... -20 to 60°C (-4 to 140°F)

Wire Material: FT-6 plenum rated cable, 22 AWG

Wire Length: 3.05 m (10')

Probe Material: 304 Series stainless steel

Probe Diameter: 6 mm (0.235")

Probe Length: 50 mm (2")

Termination: pigtail, 2 or 3 wire

Country of Origin: Canada

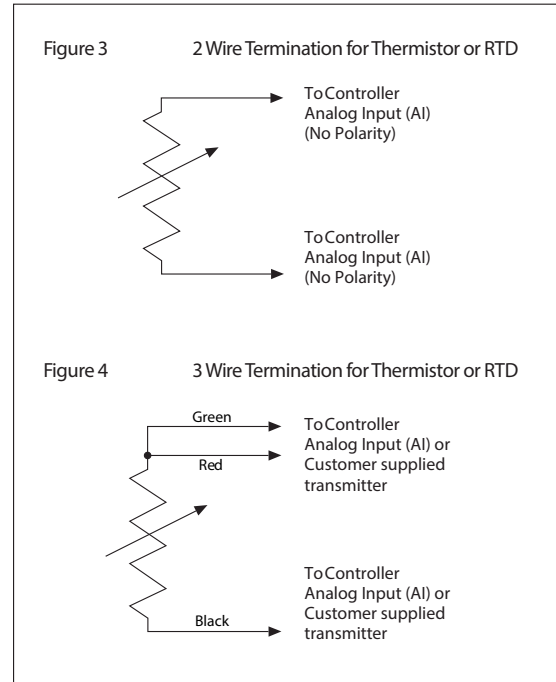

DIMENSIONS

