



INTRODUCTION

The High Accuracy Low Pressure Transducer can be used to measure positive, negative or differential pressure in the ranges of 1"wc to 20"wc. The highly accurate piezoresistive sensor is ideal for monitoring pressure of non-corrosive, non-ionic working fluids such as clean dry air or other inert gases. It features field selectable pressure ranges and output signal types for the most flexible application. Typical HVAC applications include monitoring of filter differential pressure or clean room pressure. The output signal is factory calibrated and temperature compensated for highest startup accuracy and trouble-free operation.

BEFORE INSTALLATION

Read these installation instructions carefully before commissioning the Pressure Transducer. Failure to follow these instructions may result in product damage. Do not use in an explosive or hazardous environment, with combustible or flammable gases, as safety or emergency stop devices or in any other application where failure of the product could result in personal injury. **Use electrostatic discharge precautions during installation and do not exceed the device ratings.**

MOUNTING

The transducer mounts on a vertical surface using the two integrated mounting holes. Ensure there is enough space around the unit to connect the pressure tubing without kinking and avoid locations with severe vibrations or excessive moisture. The two mounting holes will facilitate a #10 size screw (not supplied). See Figure 1. Ensure there is enough space around the unit to make the electrical connections and that it is within an acceptable distance for the length of remote sensor cable.

The enclosure has a hinged cover with a latch. Open the cover by pulling slightly on the latch on the bottom of the enclosure and at the same time pulling on the cover, as illustrated in Figure 2.

A 1/2" NPT threaded connection hole is provided on the bottom of the enclosure. Screw the EMT connector or cable gland connector in until tight. See Figure 3. It is recommended that weatherproof conduit or cable gland fittings be used. The F style enclosure includes 1/2" NPT to M16 thread adapter and cable gland fitting. See Figure 3.

Make wiring connections as per the "Wiring" illustrations on Page 2.

Swing door closed until securely latched. For added security, 2 screws are provided that may be installed in the integrated screw tabs. See Figure 4.

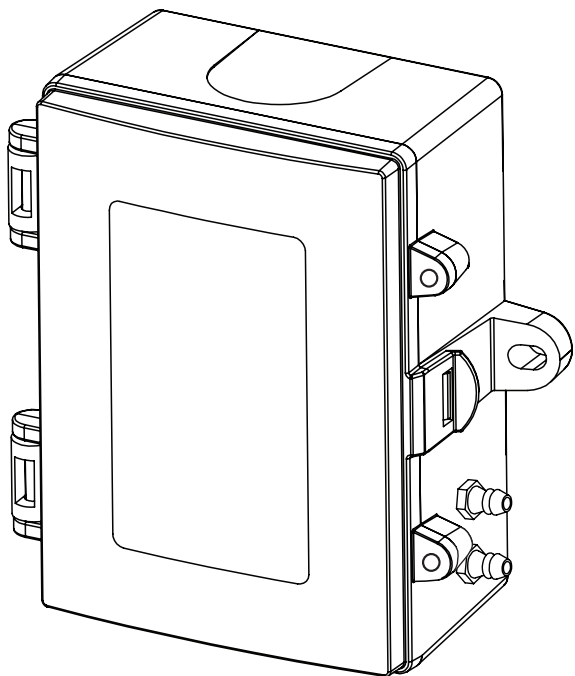

Figure 1

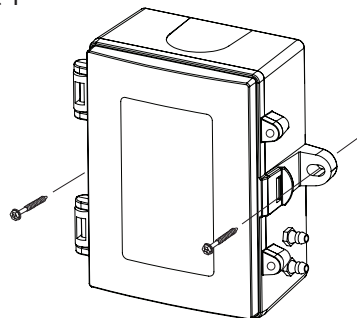

Figure 2

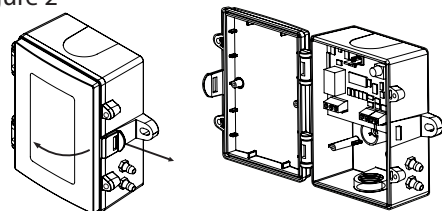

Figure 3

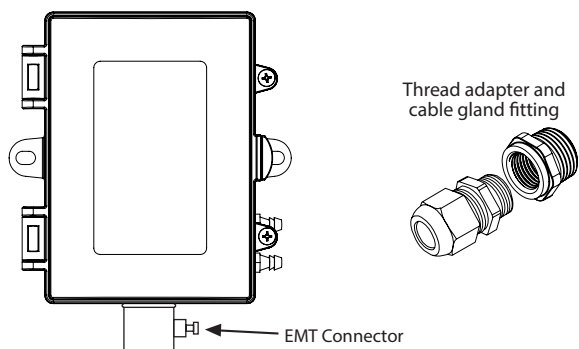
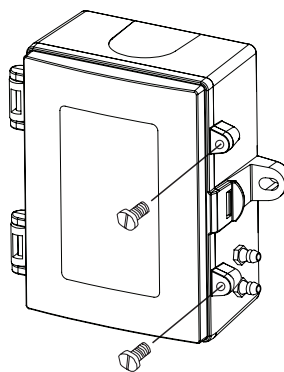

Figure 4



WIRING

The transmitter has standard screw block connectors and easy wire access to facilitate wiring. It is recommended that shielded twisted pair wiring at least 22 AWG be used for all connections and that the device wires not be run in the same conduit with wiring used to supply inductive loads such as motors. Disconnect the power supply before making any connections to prevent electrical shock or equipment damage. Make all connections in accordance with national and local electrical codes.

The device power (24 Vac/dc) is connected to the terminal marked PWR. This terminal is used for the positive dc voltage or the hot side of the ac voltage. The device is reverse voltage protected and as such will not operate if connected backwards.

For voltage output signal types (3-wire) or for AC power supply operation (3-wire), the common of the power supply is connected to the terminal marked COM. Note that this device has a half-wave type power supply which means the power supply common is the same as the output signal common. Therefore, several devices may be connected to one power supply and the output signals all share the same signal common. Use caution when grounding the secondary of an ac transformer or when wiring multiple devices to ensure that the circuit ground point is the same on all devices and the controller. This terminal is not used for loop-powered 4-20 mA output type (2-wire).

The analog output signal is available on the OUT terminal. This signal is switch selectable for either a voltage output or a standard loop-powered 4-20 mA output signal type. When voltage mode is selected, either 0-5 Vdc or 0-10 Vdc can also be selected. These options are clearly indicated on the device circuit board. The analog output signal is typically connected directly to the Building Automation System (B.A.S.) and used as a control parameter or for logging purposes.

For voltage type output signal the device has a minimum load that it is able to drive, similarly for current type output signal the device has a maximum load that it is able to drive with a particular power supply voltage. Observe and follow these ratings in the Specification section or inaccurate reading may result. The 4-20 mA output signal can easily be converted to a 1-5 Vdc signal for controllers accepting this type of input. Simply insert a 250 ohm (0.1% is best) resistor between the "+" and "-" inputs of the controller. This will convert the 4-20 mA signal to the desired 1-5 Vdc.

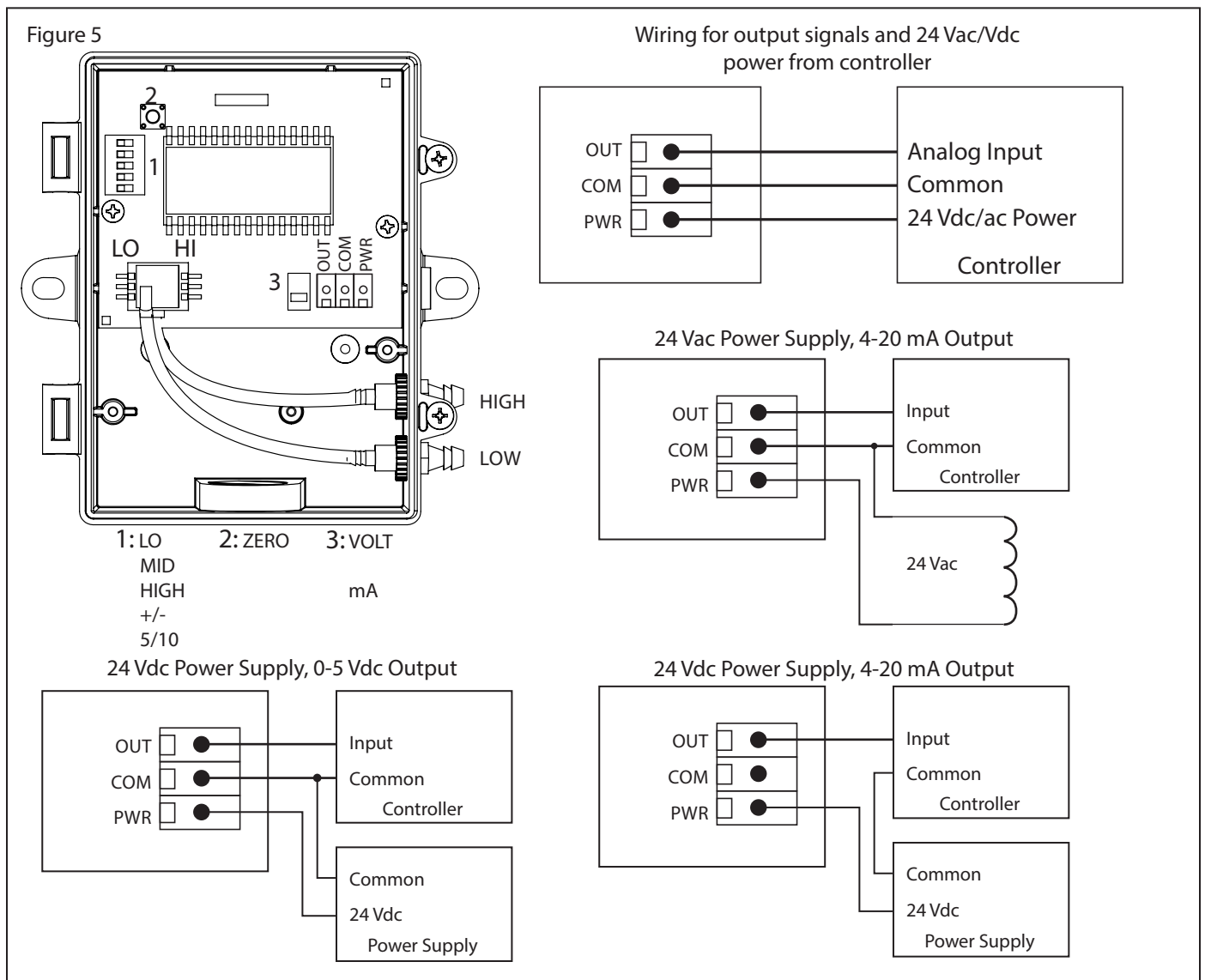

CONFIGURATION

The transmitter is configured with switches located on the circuit board as shown on the PCB drawing. These switches are used to select the output signal type and the input pressure range. The unit is factory configured to operate in the 4-20 mA output mode. This can be changed to the voltage mode by moving the switch from the position marked 4-20 mA to the position marked Voltage. Once the output mode is changed to voltage, the output scale may be changed to either 0-5 Vdc or 0-10 Vdc. This is done by moving the switch to the 5V or 10V position marked 5/10 on the five position DIP switch. The pressure range is set with a five position DIP switch.

Switch Setting	LP-00	LP-01	LP-02	LP-03	LP-04	LP-05
LOW	1" WC	3" WC	6" WC	10" WC	0.25" kPa	0.5 kPa
MID	2" WC	5" WC	10" WC	15" WC	0.5" WC	1 kPa
HIGH	4" WC	8" WC	12" WC	20" WC	1 kPa	2 kPa

For example, if the LOW range is selected on the LPX-00 model, the pressure range will be 0-1" wc. If the 4th DIP switch labeled (+/-) is also set to ON, then the pressure range will be -1 to +1" wc. This means that each model has six pressure ranges. For the LPX-00 they will be 0-1, 0-2, 0-4, ± 1, ± 2 and ± 4"wc.

PNEUMATIC CONNECTIONS

The two pressure ports on the end of the enclosure are labeled High and Low. The output signal reads a positive value when the port pressure is higher on the High port than the Low port so ensure these ports are connected correctly. Use 0.170" I.D. flexible tubing for the pressure connections. Arrange the tubing to minimize stress on the connections and ensure there are no kinks in the tubing. For most accurate measurements, do not leave the Low port open to the atmosphere, run a return line from the Low port to the vicinity of the point being measured.

Ensure the tubing to be used is clean and do not allow material to fall into the pressure ports as contamination could damage the sensor. When removing tubing use care to avoid breaking the ports. In some cases it is better to cut the tubing off rather than pulling it off but be careful not to cut the fitting or an air leak may occur.

POWER UP INSTRUCTION

Before turning on the power, verify all wiring to ensure that it complies with one of the included wiring diagrams and verify that the output signal type is correctly selected with the switches. Also, review the specifications to ensure the power supply is correct and that the pressure is within the correct range. At this time, also inspect the internal pressure tubing that connects the sensor to the external ports to ensure that the tubing did not get kinked during shipping or installation.

Proper operation can be verified by measuring the output signal. For voltage output configuration, measure the voltage between the OUT and COM terminals. The voltmeter should read between 0-5 Vdc or 0-10 Vdc depending on the output range selected. For current output configuration, insert a mA meter in series with the OUT terminal. The mA meter should read between 4 and 20 mA.

OPERATION

If the unit is set to a unipolar range such as 0-2" wc, then the pressure applied to the High port must be higher than the pressure applied to the Low port. In this case, if the Low port is left open to ambient pressure and the High port is used to measure a positive pressure, then the output pressure can be calculated as follows:

$$\begin{aligned} 4-20 \text{ mA} & \quad \text{Pressure} = [(\text{Output current} - 4 \text{ mA}) / 16 \text{ mA}] \times \text{Range} \\ 0-5 \text{ Vdc} & \quad \text{Pressure} = (\text{Output voltage} / 5 \text{ V}) \times \text{Range} \\ 0-10 \text{ Vdc} & \quad \text{Pressure} = (\text{Output voltage} / 10 \text{ V}) \times \text{Range} \end{aligned}$$

In the case of 0-2" wc, 4 mA or 0 V = 0" wc and 20 mA or 5 V or 10 V = 2" wc. Since the transmitter is linear, 1" wc would be 12 mA or 2.5 V or 5 V. If the positive pressure connection is reversed then the transmitter will always output 4 mA or 0 V.

If the unit is set to a bipolar range such as ±2" wc, then the pressure applied to the High port should be higher than the pressure applied to the Low port for a positive output response. In this case, differential pressure can be measured using both ports. If the High port has a positive pressure with respect to the Low port, then the output indicates a positive pressure. Negative pressure is indicated if the High pressure is less than the Low pressure. For bipolar ranges, the output pressure can be calculated as follows:

4-20 mA	Pressure = [(Output current - 4 mA) / 16 mA] x 2 x Range - Offset
0-5 Vdc	Pressure = (Output voltage / 5 V) x 2 x Range - Offset
0-10 Vdc	Pressure = (Output voltage / 10 V) x 2 x Range - Offset

CALIBRATION

All pressure ranges are factory calibrated and no calibration is necessary. The user may adjust the zero point if desired when changing ranges for example. Make sure the unit is warmed up for at least 10 minutes (1 hour is best) before making a zero adjustment. With both ports open to the ambient pressure, press and hold the ZERO button for at least 3 seconds. Release the button after at least 3 seconds and the device will calculate and store the new zero point.

Generally, it is not recommended that the span calibration be performed in the field unless a high quality calibrator with low differential pressure ranges is available and the temperature of the sensor can be maintained. Contact the factory for information on this type of calibration.

SPECIFICATIONS

Pressure Ranges	±4", ±2", ±1", 0-4", 0-2", 0-1" WC ±8", ±5", ±3", 0-8", 0-5", 0-3" WC ±12", ±10", ±6", 0-12", 0-10", 0-6" WC ±20", ±15", ±10", 0-20", 0-15", 0-10" WC ±1000 Pa, ±500 Pa, ±250 Pa, 0-1000 Pa, 0-500 Pa, 0-250 Pa ±2000 Pa, ±1000 Pa, ±500 Pa, 0-2000 Pa, 0-1000 Pa, 0-500 Pa (6 per model, switch selectable)
Accuracy	±0.5% F.S.O.
Measurement Type	Differential (two port), Static, Velocity, & Total Pressure
Response Time	250 ms
Stability	<±0.5% F.S.O. per year
Thermal Effects.....	<±3% over compensated range
Compensated Range.....	0 to 50°C (32 to 122°F)
Proof Pressure	40" W.C. (100" for 10" & 20" models)
Burst Pressure	60" W.C. (200" for 10" & 20" models)
Operating Conditions	0 to 70°C (32 to 158°F), 10 to 90% RH, non-condensing
Power Supply	20-28 Vac/dc (non-isolated half-wave rectified)
Supply Current	Current: 20 mA max Voltage: <4 mA min
Input Voltage Effect.....	Negligible over specified operating range
Protection Circuitry.....	Reverse voltage protected and output limited
Output Signal.....	4-20 mA (2-wire), 0-5 or 0-10 Vdc (3-wire), field selectable
Output Drive Capabilities.....	Current: 400 ohms max @ 24 Vdc Voltage: 10K ohms min
Zero Adjustments.....	Push-button auto-zero
Wiring Connections.....	Screw terminal block (14 to 22 AWG)
Pressure Connection	Barbed ports for 5 mm (0.170" ID) flexible tubing
Conduit Connection.....	1/2" NPT conduit or cable gland
Optional Display	3½" digit LCD, 0.4" digit height
Enclosure	Polycarbonate UL94-V0, IP65 (NEMA 4X) F style includes thread adapter (1/2" NPT to M16) and cable gland fitting
Approvals	CE, RoHS
Country of Origin.....	Canada

DIMENSIONS

