

# GREYSTONE ENERGY SYSTEMS INC

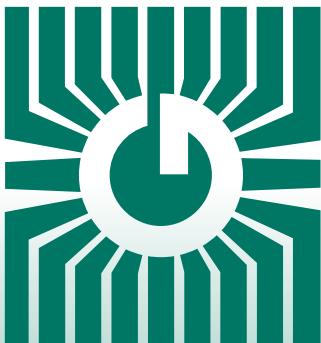

## HIGH ACCURACY PROBE TEMPERATURE SENSORS HATX Series



### Precision temperature control/sensing

#### FEATURES:

- Precision RTD sensing element
- High Accuracy Transmitter
- Choice of scaled ranges and outputs
- Various configurations
- Compact ABS Enclosure

*Peace of mind  
through reliable  
temperature monitoring*

GREYSTONE HAS AN ISO 9001 REGISTERED QUALITY SYSTEM

## SPECIFICATIONS:

Sensor .....	1000 Ω Platinum, IEC 751, 385 Alpha, thin film
Sensor Accuracy .....	<b>RTD Class A:</b> ±0.15°C @ 0°C <b>RTD 1/3 DIN:</b> ±0.1°C @ 0°C <b>RTD 1/10 DIN:</b> ±0.03°C @ 0°C
Probe Sensing Range .....	<b>AP, RP, ES, GL:</b> -20 to 105°C (-4 to 221°F) <b>BB, DC, DF, DR, FL:</b> -20 to 60°C (-4 to 140°F) <b>OS:</b> -40 to 50°C (-40 to 122°F)
Wire Material .....	<b>AP, DR, RP, SO, GL:</b> PVC insulated, parallel bonded, 22 AWG <b>DC, DF, FL:</b> FT-6 rated plenum cable, 22 AWG
Probe Material .....	<b>AP, BB, DR, FL, RP:</b> 6.00 mm (0.236") O.D., 304 series stainless steel <b>DC:</b> 7.94 mm (0.3125") O.D. soft copper <b>DF:</b> FT-6 rated plenum cable <b>SO:</b> 2" x 2" aluminum plate <b>GL:</b> 0.5" x 0.5" x 2" aluminum wafer
Output Signal .....	4-20 mA current loop, 0-5 Vdc, or 0-10Vdc (Factory Configured)
Transmitter Accuracy .....	±0.1% of span, including linearity
4-20 mA Loop Power Supply .....	15-35 Vdc or 22-32 Vac
Minimum Loop Current .....	2 mA nominal (occurs with shorted sensor)
Maximum Loop Current .....	22.5 mA nominal (occurs with open sensor)
Maximum Loop Load .....	>600 ohms
0-5 Vdc Power Supply .....	10-35 Vdc or 10-32 Vac
0-10 Vdc Power Supply .....	15-35 Vdc or 15-32 Vac
Maximum Current (Voltage) .....	5 mA nominal
Maximum Output (Voltage) .....	Limited to <5.5 Vdc, <10.5 for 0-10 Vdc
Input Voltage Effect .....	Negligible over specified operating range
Protection Circuitry .....	Reverse voltage protected and output limited
Ambient Operating Range .....	<b>AP, DC, DF, DR, RP, SO, FL, GL:</b> 0 to 50°C (32 to 122°F) <b>OS:</b> -40 to 50°C (-40 to 122°F)
Enclosure .....	<b>A:</b> Hinged cover - ABS - UL94-V0 - IP65 (NEMA 4X) <b>E:</b> Hinged cover - ABS with thread adaptor (1/2" NPT to M16) and cable gland fitting Conduit connection - 1/2" NPT threaded connection
Wiring Connections .....	Screw terminal block (14, 20, 22 AWG)
Country of Origin .....	Canada
*This product is factory calibrated and any field adjustment will void the warranty.	
NOTE: For higher temperature applications please contact Greystone.	

## HATX - HIGH ACCURACY PROBE TEMPERATURE SENSOR CONFIGURATIONS

### FEATURES:

The HATX temperature transmitters offer a choice of precision platinum or nickel RTD's, or NTC Thermistors which can be interfaced with a computerized monitoring or control system. A wide variety of configurations are available such as:

**AP Duct/Immersion Sensor** – The AP is for single point monitoring. Both are available with various probe lengths.

AP)



**DC, DF & DR) Duct Averaging Sensor** – All models incorporate numerous sensors along the assembly and act as a single sensor averaging the temperature across the sensors. They are available in various lengths. The DF probe is constructed of FT-6 rated plenum cable which allows for easy installation. The DC probe is constructed of bendable soft copper and the DR is a constructed of rigid stainless steel.

DC)



DF)



DR)



**RP & SO) Strap-on Sensor** – The RP comes with stainless steel probe and is available in several lengths and 1.5 m (5') of cable for remote mounting. The SO has an aluminum plate with an expandable 10" clamp assembly to strap directly to a pipe. Various enclosures are available.

RP)



SO)



**OS (Outside Sensor)** – Comes in a weather-proof enclosure which incorporates a sun/windshield to protect the sensor.

OS)



**FL) Flying Lead** – The sensor is encapsulated in a 2" S/S probe with 6' of FT-6 rated cable and can be used in almost any application where temperature monitoring is required.

FL)



**GL)** – The sensor is encapsulated in a 1/2" square x 2" aluminum wafer that can be affixed to any surface. It comes with 5' of zip cable.

GL)



# PRODUCT ORDERING INFORMATION:

MODEL	Product Description
HATX	High Accuracy Temperature Transmitter Series

CODE	Mounting Style
AP	All Purpose Duct/Immersion
DC	Duct Average, copper probe
DF	Duct Average, flexible cable
DR	Duct Average, rigid stainless steel probe
RP	Remote Probe – strap-on
SO	Strap-On – assembly clamps around pipe with aluminum plate with 254 mm (10") stainless clamp
OS	Outside Air
FL	Flying Lead
GL	Glass

CODE	Enclosure
A	ABS, with hinged and gasketed cover
E	ABS, with hinged and gasketed cover, with thread adapter and cable gland fitting

CODE	Sensor
18	1000 Ω, Platinum, wire 2, IEC 751, 385 Alpha, thin film, Class A
48	1000 Ω, Platinum, 2 wire, IEC 751, 385 Alpha, thin film, 1/3 DIN
22	1000 Ω, Platinum, 2 wire, IEC 751, 385 Alpha, thin film, 1/10 DIN

CODE	Probe Length	Lengths are applicable to these mounting styles
X	Not applicable	SO, OS, FL, & GL
A	50 mm (2")	AP & RP
B	100 mm (4")	AP & RP
C	150 mm (6")	AP & RP
D	200 mm (8")	AP & RP
E	300 mm (12")	AP
F	450 mm (18")	AP & DR
G	600 mm (24")	DR
H	900 mm (36")	DR
I	1800 mm (6')	DC & DF
J	3600 mm (12')	DC & DF
K	6100 mm (20')	DC & DF
L	7300 mm (24')	DC & DF

CODE	Output
A	4-20 mA 2 or 3 wire
D	0-5 VDC 3 wire
E	0-10 VDC 3 wire

  

CODE	Scaled Range
001	0°C to 35°C (32°F to 95°F)
002	0°C to 50°C (32°F to 122°F)
003	0°C to 100°C (32°F to 212°F)
006	-50°C to 50°C (-58°F to 122°F)

HATX	AP	A	18	E	A	002
------	----	---	----	---	---	-----

## ENCLOSURE DIMENSIONS

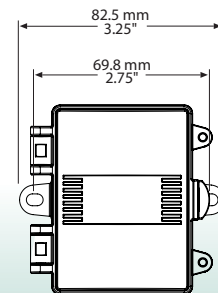
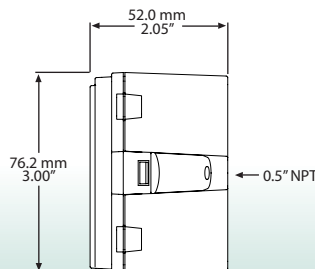
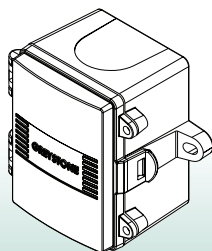

## THERMOWELLS:



**NOTE:**  
6" and up machined thermowells have a two step stem as shown. welded construction have a 9.5 mm (0.375") diameter

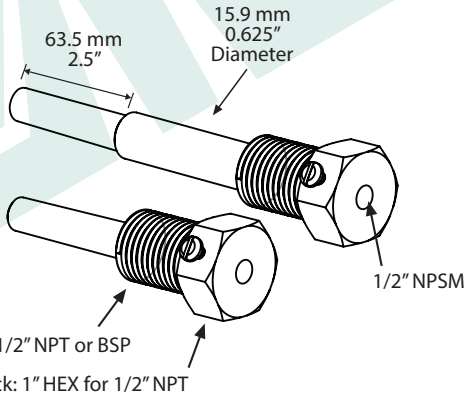
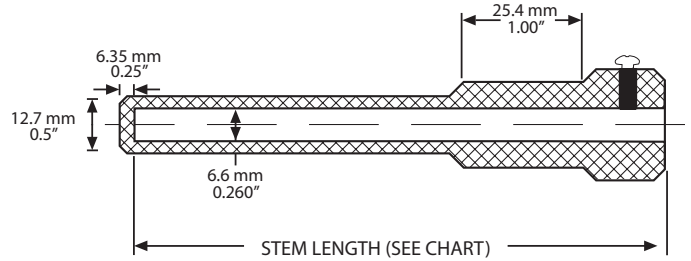

### THERMOWELL PART NUMBERING SYSTEM

SERIES NUMBER	NPT THREAD SIZE		MATERIAL	STEM LENGTH
T2	1/2"	N = NPT B = BSP	P - 304 SS R - 316 SS	2" 4" 6" 8" 12" 18"

EXAMPLE: T2 1/2 N P 4  
4" 304 STAINLESS THERMOWELL  
WITH 1/2" NPT PROCESS THREAD

## ACCESSORIES:

Thread adapter and cable gland fitting are included with the E style enclosure option.

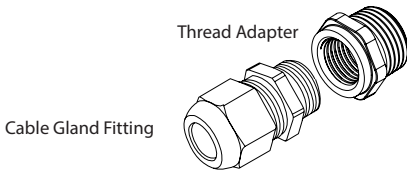

**GREYSTONE**  
ENERGY SYSTEMS INC

Greystone Energy Systems Inc.  
150 English Drive, Moncton,  
New Brunswick, Canada E1E 4G7  
(506) 853-3057 Fax: (506) 853-6014  
North America: 1-800-561-5611  
e-mail: mail@greystoneenergy.com  
www.greystoneenergy.com



*Greystone Energy Systems Inc. is one of North America's largest ISO registered manufacturers of HVAC/R sensors and transmitters for Building Automation Management Systems.*

*We have conscientiously established a worldwide reputation as an industry leader by maintaining leading-edge design technology, prompt technical support, and a commitment to on-time deliveries. We take pride in our Quality Management System which is ISO 9001 certified, assuring our customers of consistent product reliability.*

GREYSTONE HAS AN ISO 9001 REGISTERED QUALITY SYSTEM