



GREYSTONE ENERGY SYSTEMS INC

HIGH ACCURACY ALL PURPOSE TEMPERATURE SENSOR TSAP Series

The high accuracy all purpose single point temperature sensor utilizes a precision sensor encapsulated in a 6 mm (0.236") OD, 304 series stainless steel probe and is available in various lengths (see ordering chart). All probes provide excellent heat transfer, fast response and resistance to moisture penetration.



SPECIFICATION:

Sensor Type Various Thermistor or RTD
 Sensor Accuracy..... **RTD Class A:** $\pm 0.15^{\circ}\text{C}$ @ 0°C
 RTD 1/3 DIN: $\pm 0.1^{\circ}\text{C}$ @ 0°C
 RTD 1/10 DIN: $\pm 0.03^{\circ}\text{C}$ @ 0°C
 NTC Thermistor Type 39: $\pm 0.05^{\circ}\text{C}$, 0 to 70°C
 NTC Thermistor Type 55: $\pm 0.03^{\circ}\text{C}$, 0 to 70°C
 NTC Thermistor Type 40/46: $\pm 0.1^{\circ}\text{C}$, 0 to 70°C
 Temperature Range..... -20 to 105°C (-4 to 221°F)
 Wire Material..... PVC insulated, parallel bonded, 22 AWG
 Probe Material 304 Series stainless steel
 Probe Diameter..... 6 mm (0.236")
 Standard Lengths..... 50, 100, 150, 200, 300, and 400 mm
 (2", 4", 6", 8", 12", and 18")
 Enclosure..... ABS - UL94-V0, IP65 (NEMA4X)
 C - includes terminal block
 E - includes thread adapter (1/2" NPT to M16),
 cable gland fitting, and terminal block
 Termination A - pigtail, 2 or 3 wire
 C & E - terminal block, 2 or 3 wire
 Country of Origin..... Canada

PART NUMBER SELECTED

PRODUCT SELECTION INFORMATION:

MODEL	Product Description
HATSAP	High Accuracy All Purpose Duct/Immersion Temperature Sensor

CODE	Enclosure
A	ABS, with hinged & gasketed cover
C	Same as A, with terminal block
E	Same as C, with thread adapter and cable gland fitting

CODE	Sensor
18	1000 Ω Platinum, 2 wire, IEC 751, 385 Alpha, thin film, Class A
48	1000 Ω Platinum, 2 wire, IEC 751, 385 Alpha, thin film, 1/3 DIN
22	1000 Ω Platinum, 2 wire, IEC 751, 385 Alpha, thin film, 1/10 DIN
41	1000 Ω Platinum, 3 wire, IEC 751, 385 Alpha, thin film, Class A
49	1000 Ω Platinum, 3 wire, IEC 751, 385 Alpha, thin film, 1/3 DIN
50	1000 Ω Platinum, 3 wire, IEC 751, 385 Alpha, thin film, 1/10 DIN
39	10,000 Ω Type 2, NTC Thermistor, $\pm 0.05^{\circ}\text{C}$
55	10,000 Ω Type 2, NTC Thermistor, $\pm 0.03^{\circ}\text{C}$
40	10,000 Ω Type 3, NTC Thermistor, $\pm 0.1^{\circ}\text{C}$
46	20,000 Ω , NTC Thermistor, $\pm 0.1^{\circ}\text{C}$

CODE	Probe Length
A	50 mm (2")
B	100 mm (4")
C	150 mm (6")
D	200 mm (8")
E	300 mm (12")
F	450 mm (18")

Greystone Energy Systems, Inc. reserves the right to make design modifications without prior notice.

TYPICAL INSTALLATION:

For complete installation and wiring details, please refer to the product installation instructions.

In duct applications the probes are installed in the side of the duct to monitor a single point temperature within the duct. Select a probe length that allows the probe to span the duct width. Install the probe in a straight section of duct at a suitable distance downstream from any heating, cooling or humidification devices.

For immersion applications the probes are installed in the appropriate length thermowell for the pipe size. Thermal conductive compound should be added inside the thermowell to provide optimum thermal transfer.

NOTE: All immersion sensors require a thermowell (sold separately).

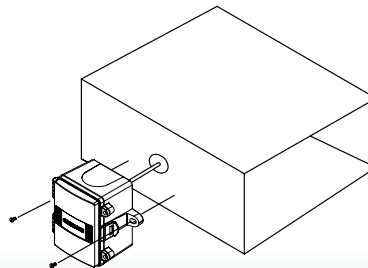

DIMENSIONS:

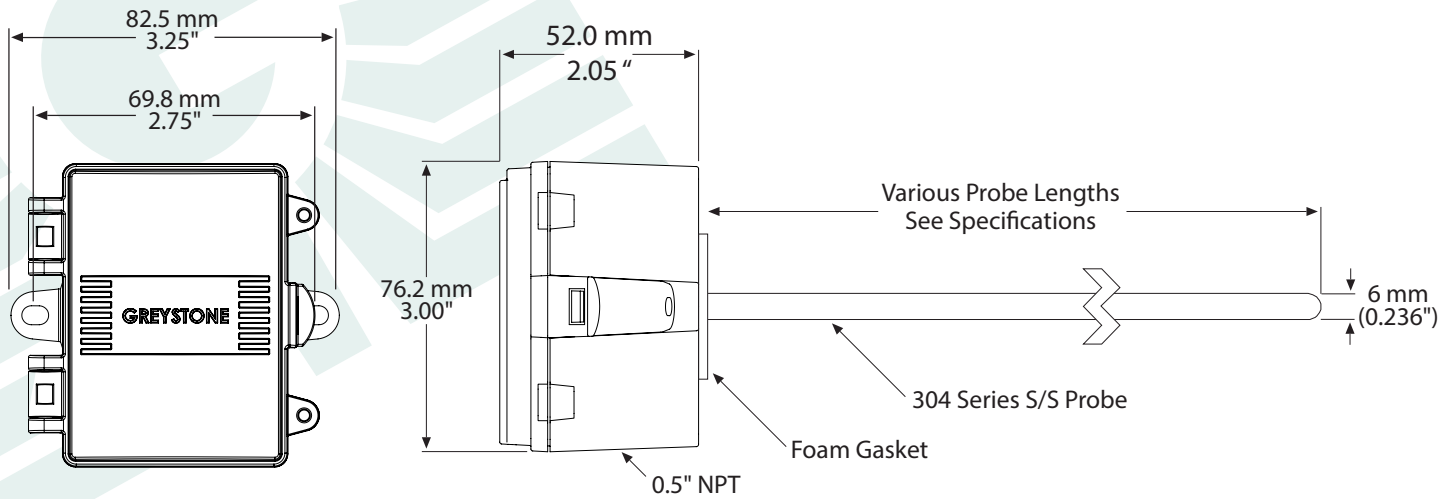

Included with E style enclosure

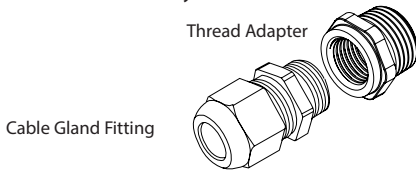

GREYSTONE

ENERGY SYSTEMS INC

Greystone Energy Systems, Inc.
150 English Drive, Moncton,
New Brunswick, Canada E1E 4G7

(506) 853-3057 Fax: (506) 853-6014
North America: 1-800-561-5611
e-mail: mail@greystoneenergy.com
www.greystoneenergy.com

RoHS
COMPLIANT



Greystone Energy Systems Inc. is one of North America's largest ISO registered manufacturers of HVAC/R sensors and transmitters for Building Automation Management Systems.

We have conscientiously established a worldwide reputation as an industry leader by maintaining leading-edge design technology, prompt technical support, and a commitment to on-time deliveries. We take pride in our Quality Management System which is ISO 9001 certified, assuring our customers of consistent product reliability.

GREYSTONE HAS AN **ISO 9001** REGISTERED QUALITY SYSTEM