

INTRODUCTION

The high accuracy single point glass temperature sensor utilizes a precision sensor encapsulated in a 31.75mm L x 9.525mm H x 9.525mm W (1.25" x 0.375" x 0.375") aluminum probe. Standard length is 600mm (24"). All probes are constructed to provide excellent heat transfer, fast response and are potted to resist moisture penetration.

BEFORE INSTALLATION

Read these instructions carefully before installing and commissioning the temperature sensor. Failure to follow these instructions may result in product damage. Do not use in an explosive or hazardous environment, with combustible or flammable gases, as a safety or emergency stop device or in any other application where failure of the product could result in personal injury. **Do not exceed the device ratings.**

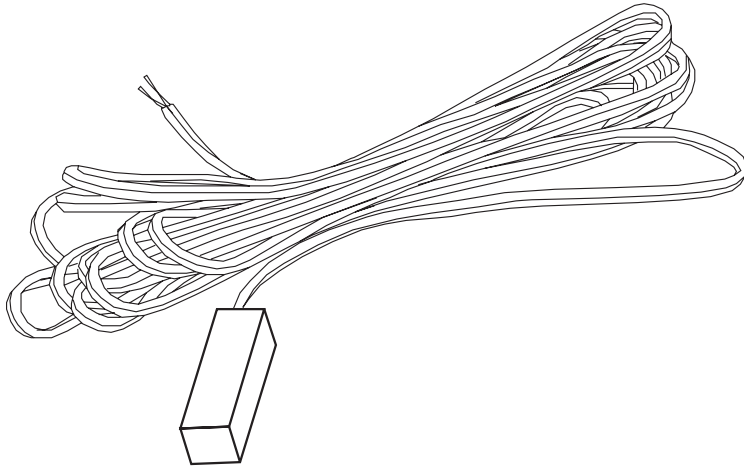

MOUNTING

The glass sensor installs directly onto any window. Select a suitable location on an exterior window where the probe can be mounted. On one side of the probe apply epoxy compound and press firmly against the glass. See Figure 1. Use whatever means available (electrical tape will do) to secure the probe to the window while the epoxy sets. To achieve the best reading, do not place in an area where air stratification may be present. Avoid areas where the sensor is exposed to vibrations or rapid temperature changes.

Make wire connections as per the "Wiring" illustrations on Page 2.

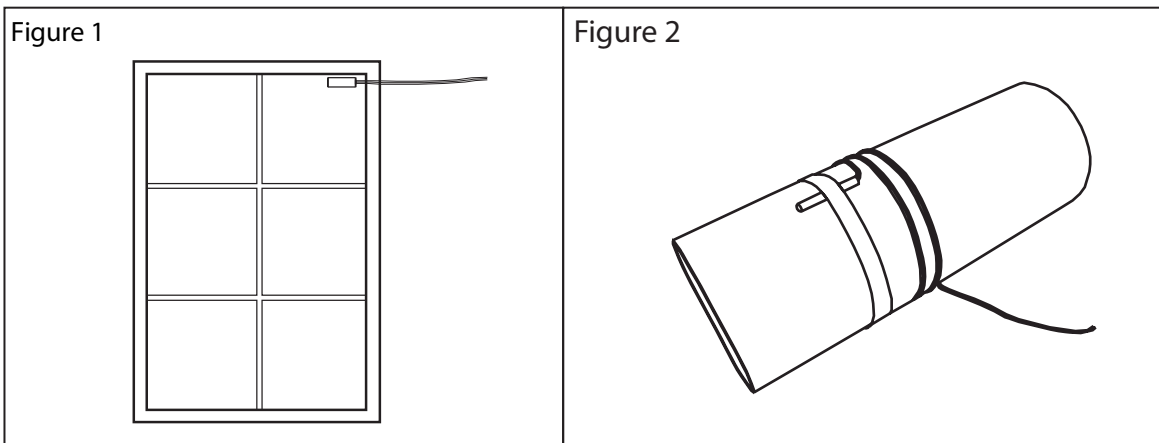

WIRING

- Use 18-24 AWG shielded wiring for all connections. Do not locate the device wires in the same conduit with wiring used to supply inductive loads such as motors. Make all connections in accordance with national and local codes.
- Pull at least six inches of wire into the enclosure, then complete the wiring connection according to the wiring diagrams below.
- All thermistors and most RTD's are a two wire hook up and are not polarity sensitive. See Figure 3.
- For RTD's that are 3 wire connection see Figure 4.

TYPICAL WIRE RESISTANCE VALUES

When using low resistance sensors, long wire runs can add significant error to the readings. Use the following chart to determine errors due to wire resistance or consider using a 1000 ohm sensor or a transmitter for better accuracy. Locate the type of wire being used. Multiply the total length of the wire (distance from the controller to the sensor and back) by the number found in the chart below for total resistance.

GAUGE WIRE TYPE	18 AWG	22 AWG	24 AWG
STRANDED (OHMS/FOOT)	5.85 mΩ	14.75 mΩ	23.29 mΩ
SOLID (OHMS/FOOT)	6.4 mΩ	15.85 mΩ	25.72 mΩ

SPECIFICATIONS:

Sensor Type Thermistor or RTD

Sensor Accuracy:.....**RTD Class A:** $\pm 0.15^{\circ}\text{C}$ @ 0°C
RTD 1/3 DIN: $\pm 0.1^{\circ}\text{C}$ @ 0°C
RTD 1/10 DIN: $\pm 0.03^{\circ}\text{C}$ @ 0°C
NTC Thermistor Type 39: $\pm 0.05^{\circ}\text{C}$, 0 to 70°C
NTC Thermistor Type 55: $\pm 0.03^{\circ}\text{C}$, 0 to 70°C
NTC Thermistor Type 40/46: $\pm 0.1^{\circ}\text{C}$, 0 to 70°C

Temperature Range -20 to 105°C (-4 to 221°F)

Wire Material PVC insulated, parallel bonded

Probe Length 1.524 m (5')

Probe Material Aluminum

Probe Dimensions 31.75mm L x 95.25mm W x 9.525mm H
 (1.25" x 0.375" x 0.375")

Termination pigtail, 2 or 3 wire

Country of Origin Canada

DIMENSIONS

