

# High Accuracy Outside Humidity Transmitter

## Installation Instructions

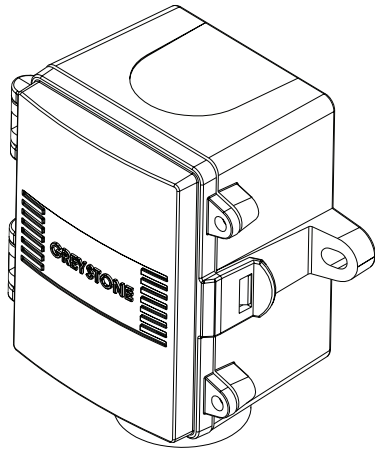

### INTRODUCTION

The high accuracy outside humidity transmitter uses a highly accurate and reliable Thermoset Polymer based capacitance humidity sensor and state-of-the-art digital linearization and temperature compensated circuitry in an weatherproof enclosure to monitor outside humidity levels. Sensors are mounted in a sun and wind shield for more accurate monitoring. An optional temperature sensor is also available

### BEFORE INSTALLATION

Read these instructions carefully before installing and commissioning the humidity transmitter. Failure to follow these instructions may result in product damage. Do not use in an explosive or hazardous environment, with combustible or flammable gases, as a safety or emergency stop device or in any other application where failure of the product could result in personal injury. **Take electrostatic discharge precautions during installation and do not exceed the device ratings.**

### MOUNTING

Select a suitable mounting spot on an exterior wall where the outside humidity transmitter is best protected from direct exposure to sunlight, wind, etc. preferably on a North facing wall. Do not mount the sensor near opening windows, supply/exhaust air louvres or other known air disturbances. Avoid areas where the sensor is exposed to vibrations or rapid temperature changes.

The sensor provides a connection hole for 1/2" Conduit. Run a length of conduit through exterior wall and seal. Use 14-22 AWG shielded wiring for all connections and do not locate the device wires in the same conduit with wiring used to supply inductive loads such as motors. Make all connections in accordance with national and local codes.

The sensor installs directly on an exterior wall using the two integrated mounting holes provided on the enclosure. Select the best mounting technic based on the exterior wall material. The two mounting holes will facilitate a #10 size screw (not supplied). The sensor fitting must be pointing down. See Figure 1.

The enclosure has a hinged cover with a latch. Open the cover by pulling slightly on the latch on the right side of the enclosure, at the same time pulling on the cover, as illustrated in Figure 2.

Feed conduit through the provided hole in the back of the enclosure and secure with a lock nut as shown in Figure 3. It is recommended that weatherproof conduit or cable gland fittings be used.

Make wiring connections as per the "Wiring" illustrations on Page 2.

Swing door closed until securely latched. For added security, 2 screws are provided that may be installed in the integrated screw tabs. See Figure 4.

Figure 1

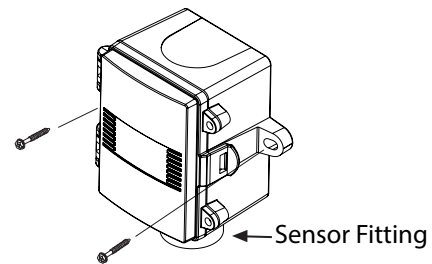

Figure 2

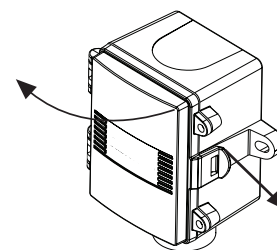

Figure 3

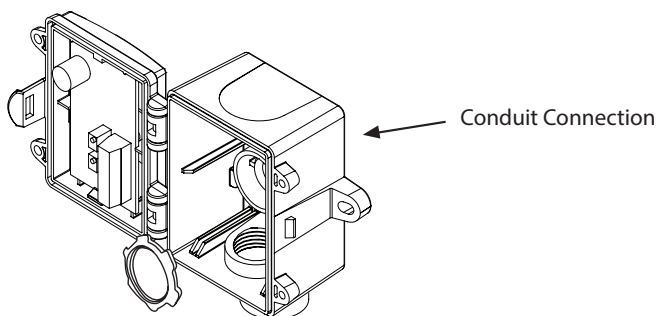
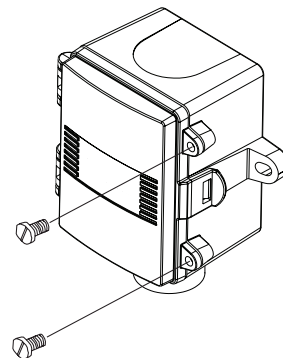
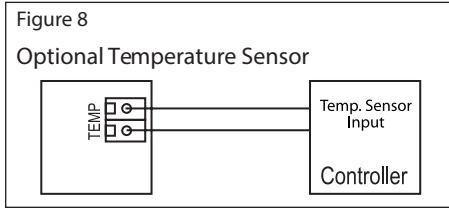
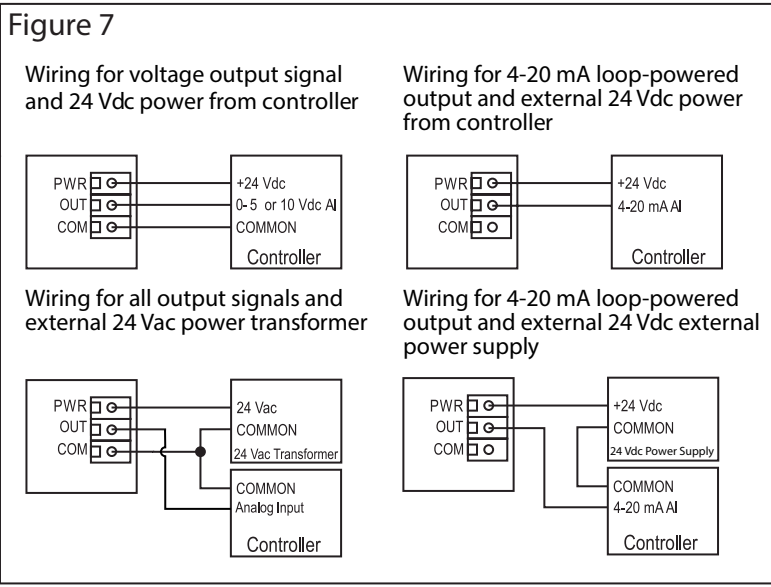
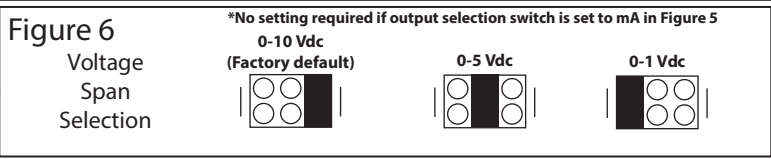
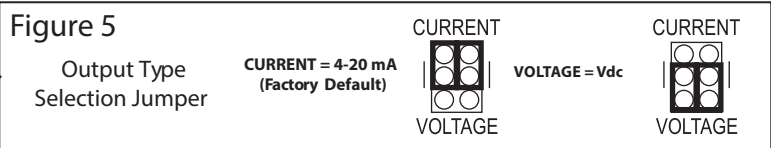
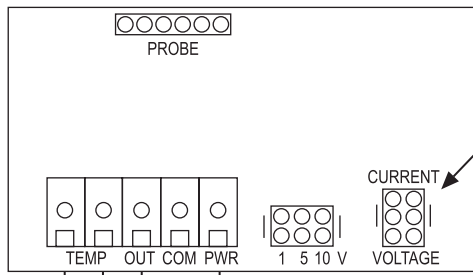

Figure 4



# WIRING

- Deactivate the 24 Vac/dc power supply until all connections are made to the device to prevent electrical shock or equipment damage.
- Use 14-22 AWG shielded wiring for all connections and do not locate the device wires in the same conduit with wiring used to supply inductive loads such as motors. Make all connections in accordance with national and local codes.
- Pull at least six inches of wire into the enclosure, then complete the wiring connection according to the wire diagram for the applicable power supply and output signal type.
- Select desired signal output type (mA or Vdc) by placing the output jumper in required position, as shown in Figure 5. Factory default is mA (4-20 mA).
- If mA was selected, no further Output set up is required. If VOLT output is selected in Figure 5, place Voltage Output Jumper to desired span position, as shown in Figure 6. ie: 10 = 0-10 Vdc. Factory default is 0-10 Vdc.
- Connect the DC positive or the AC voltage hot side to the PWR terminal. For voltage output or AC power, the supply Common is connected to the COM terminal. The device is reverse voltage protected and will not operate if connected backwards. It has a half-wave power supply so the supply Common is the same as the signal Common. See Figure 7.
- The analog output is available on the OUT terminal. Check the controller Analog Input to determine the proper connection before applying power as shown in Figure 6.
- If installed, the resistance temperature output is available on the two terminals labelled TEMP as shown in Figure 8.



## SPECIFICATIONS:

Sensor Type:.....Thermoset Ploymer based Capacitive  
 Sensor Accuracy:.....±1% (20 to 80 %RH) or ±2% (5 to 95 %RH)  
 Measurement Range:.....0 to 100% RH  
 Sensor Response Time:.....15 Seconds typical  
 Temp Dependence:.....±0.05% RH/°C  
 Hysteresis:.....±1.5% RH maximum  
 Repeatability:.....±0.5% RH typical  
 Linearity:.....±0.5% RH typical  
 Stability:.....±1% RH typical at 50% RH in 5 yrs.  
 Operating Range:.....-40 to 85°C (-4 to 185°F)  
 Operating Humidity:.....0 to 95% RH non-condensing  
 Power Supply:.....18 to 30 Vdc, 15 to 26 Vac  
 Consumption:.....22 mA maximum  
 Input Voltage Effect:.....Negligible over specified operating range  
 Protection Circuitry:.....Reverse Voltage protected and output limited  
 Output Signal:.....4-20 mA current loop, 0-5 Vdc, 0-10 Vdc, or 0-1 Vdc (jumper selectable)  
 Output Drive @ 24 Vdc:.....550 ohms max for current output  
 .....10K ohms min for current output  
 Internal Adjustments:.....Clearly marked ZERO and SPAN pots  
 Optional Temp Sensor:.....Various RTDs or thermistors available as two-wire resistance output

## OPTIONAL TEMPERATURE

Sensor Type.....Platinum RTD 1000 Ω, 385 Alpha @ 0°C  
 .....NTC Thermistor, 10,000 Ω Type 2/3 or 20,000 Ω @ 25°C  
 Accuracy.....**RTD Class A:** ±0.15°C @ 0°C  
 .....**RTD 1/3 DIN:** ±0.1°C @ 0°C  
 .....**RTD 1/10 DIN:** ±0.03°C @ 0°C  
 .....**Thermistor (39):** ±0.05°C, 0 to 70°C  
 .....**Thermistor (40/46):** ±0.1°C, 0 to 70°C  
 .....**Thermistor (55):** ±0.03°C, 0 to 70°C

## DIMENSIONS

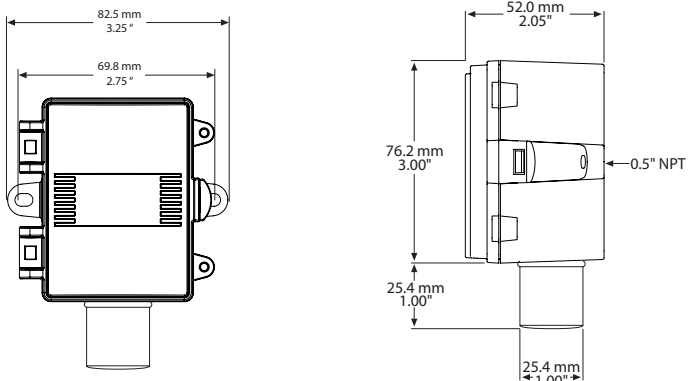

PRINTED IN CANADA