

GREYSTONE

ENERGY SYSTEMS INC

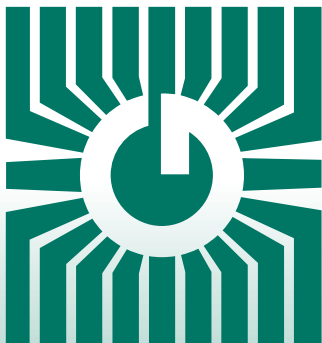

LOW PRESSURE TRANSMITTER ELP Series



Precision pressure control/sensing

FEATURES:

- Ranges available: 1" though 20", 250 through 5000 Pa
- Two jumper selectable ranges per model
- Jumper selectable current or voltage output
- Polycarbonate enclosure with hinged and gasketed cover

*Peace of mind
through reliable
pressure monitoring*

GREYSTONE HAS AN ISO 9001 REGISTERED QUALITY SYSTEM

SPECIFICATIONS:

Accuracy.....	±1% F.S.O.
Measurement Type.....	Differential (ELP-X) or Static (ELP-S)
Response Time.....	250 ms
Stability.....	< ±1% F.S.O. per year
Thermal Effects.....	< ±3% over compensated range
Compensated Range.....	-25 to 85° C (-13 to 185°F)
Proof Pressure.....	100" W.C. (200" for 5", 10" & 20" models)
Burst Pressure.....	300" W.C. (500" for 20" models)
Operating Conditions.....	0 to 50°C (32 to 122°F), 10 - 90 %RH, non-condensing
Power Supply.....	20 to 28 Vac/dc (non-isolated half-wave rectified)
Supply Current.....	Current: 20 mA max Voltage: < 4 mA
Input Voltage Effect.....	Negligible over operating range
Protection Circuitry.....	Reverse voltage protected and output limited

Output Signal.....	4-20 mA (2 wire) or 0-10 Vdc (3 wire), switch selectable
Output Drive Capabilities.....	Current: 400 ohms max @ 24 vdc Voltage: 10K ohms min
Zero Adjustments.....	Pushbutton auto-zero
Wiring Connections.....	Screw terminal block (14 to 22 AWG)
Pressure Connection.....	Barbed ports for 5 mm (0.170" ID) flexible tubing
Conduit Connection.....	½" NPT conduit or cable gland
Enclosures.....	Polycarbonate UL94-V0, IP65 (NEMA 4X) F style includes thread adapter (1/2" NPT to M16) and cable gland fitting
Approvals.....	CE, RoHS
Country of Origin.....	Canada

ELP - LOW PRESSURE TRANSMITTER CONFIGURATIONS

FEATURES:

The Low Pressure Transmitter can be used to measure positive, negative or differential pressure in the ranges of 1"wc to 20"wc. The highly accurate piezoresistive sensor is ideal for monitoring pressure of non-corrosive, non-ionic working fluids such as clean dry air or other inert gases. It features field selectable pressure ranges and output signal types for the most flexible application. Typical HVAC applications include monitoring of filter differential pressure or clean room pressure. The output signal is factory calibrated and temperature compensated for highest startup accuracy and trouble-free operation.



PRODUCT SELECTION INFORMATION:

MODEL	Product Description
ELP	Low Pressure Transmitter

CODE	Enclosure
B	Polycarbonate with hinged and gasketed cover
F	Same as B, with thread adapter and cable gland fitting

CODE	Output
0001W	±1" / 0-1 "wc
0002W	±2" / 0-2 "wc
0005W	±5" / 0-5 "wc
0010W	±10" / 0-10 "wc
0020W	±20" / 0-20 "wc
0250P	±250 / 0-250 Pa
0500P	±500 / 0-500 Pa
1250P	±1250 / 0-1250 Pa
2500P	±2500 / 0-2500 Pa
5000P	±5000 / 0-5000 Pa

CODE	Probe
X	No Probe
S	Static Probe

Greystone Energy Systems, Inc. reserves the right to make design modifications without prior notice.

DIMENSIONS:

ELP-X

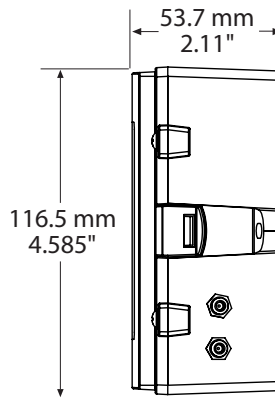
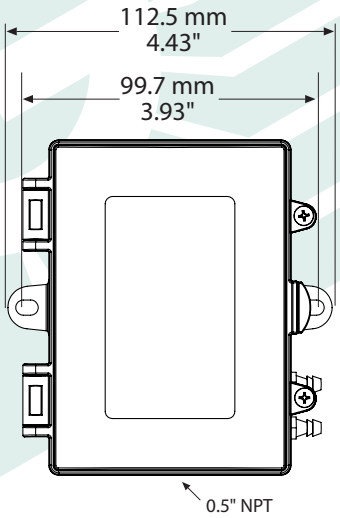

ELP-S

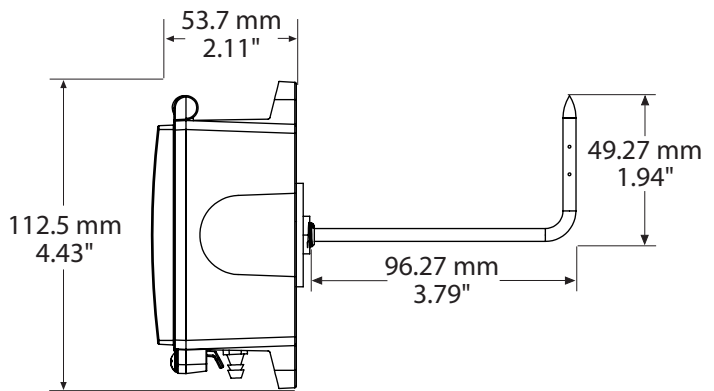
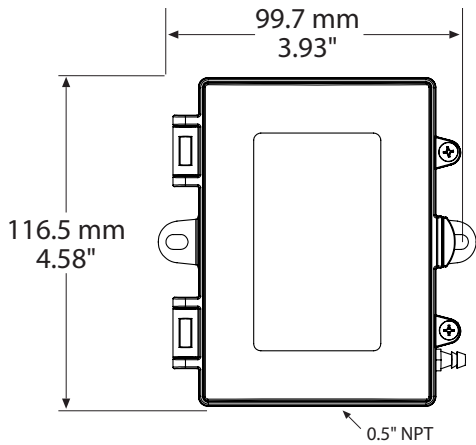

Included with F style enclosure

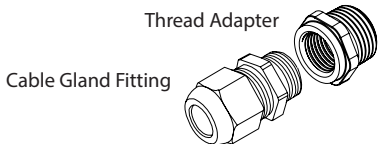

ACCESSORIES:

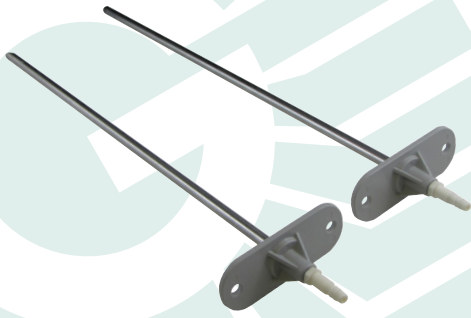

FPP & SPP Series Pitot Tube

The FPP and SPP series are used to sense velocity pressure or static pressure respectively. Constructed of 304 series stainless steel probes with an ABS mounting bracket, they are available in 150 mm (6") or 300 mm (12") lengths. Kits are available for differential and static that are complete with pneumatic tubing.



DPFS Series Differential Pressure Probe

The DPFS series Averaging Flow Sensor is ideal for sensing differential pressure in the inlet section of variable air volume terminal units and fan terminal units. Units can also be used to sense differential pressure at other locations on the main or branch duct systems. They are made of ABS/polycarbonate (UL94-5V) and available in lengths from 100 mm (4") to 560 mm (22").

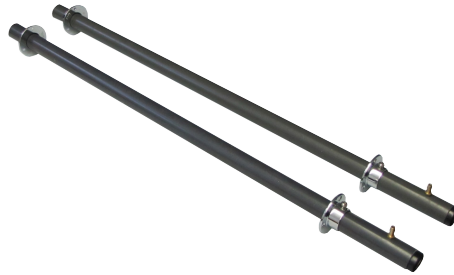

MP Series Differential Pressure Probes

The MP series Air Velocity Pitot Tubes are used in conjunction with a DP transmitter to calculate airflow in larger ducts or in areas of turbulent airflow. The units come in pairs in either ABS or 316 S/S and are available in various lengths from 610 mm (24") to 2000 mm (80"). Gasketed mounting collars for both probes are included.



GREYSTONE ENERGY SYSTEMS INC

Greystone Energy Systems Inc.
150 English Drive, Moncton,
New Brunswick, Canada E1E 4G7
(506) 853-3057 Fax: (506) 853-6014
North America: 1-800-561-5611
e-mail: mail@greystoneenergy.com
www.greystoneenergy.com

RoHS
COMPLIANT



Greystone Energy Systems Inc. is one of North America's largest ISO registered manufacturers of HVAC/R sensors and transmitters for Building Automation Management Systems.

We have conscientiously established a worldwide reputation as an industry leader by maintaining leading-edge design technology, prompt technical support, and a commitment to on-time deliveries. We take pride in our Quality Management System which is ISO 9001 certified, assuring our customers of consistent product reliability.

GREYSTONE HAS AN ISO 9001 REGISTERED QUALITY SYSTEM