

← WARNING →

- **Electric Shock Hazard, Use Caution**
- Disconnect and lock out power before installation
- Follow national and local electrical codes
- Read and understand these instructions before installing
- Installation only by qualified electrical personnel
- Do not rely on this device to indicate line power
- Only install this device on insulated conductors
- Only install on 600 Vac maximum conductors
- Do not use this device for life-safety applications
- Do not install in hazardous or classified locations
- Install this product in a suitable electrical enclosure
- **Failure to follow these instructions will result in death or serious injury.**

Specifications

- Setpoint Range 1 - 200 Amps adjustable
- Maximum Input Current . . . 200 Amps continuous
- Sensor Power Self-powered
- Output Type Solid-state mosfet
- Output Switch Action Normally open
- Output Switch Ratings . . . 30 Vac/dc, 500 mA maximum
- Indication Power and status LEDs
- Von at 24 Vdc at 500 mA . < 50 mV
- Frequency 50/60 Hz
- Response Time 200 mS typical
- Insulation Class 600 Vac, insulated conductors
- Operating Temperature . . . -15 to 50 °C (5 to 122 °F)
- Operating Humidity 5 to 90 %RH, non-condensing
- Terminal Block 14 to 22 AWG
- Dimensions 2.65 x 2.7 x 0.95 in
(67 x 68.6 x 24.1 mm)
- Sensor Aperture 0.8 in (20.3 mm)
- Enclosure Material ABS/PC, UL94 V-0
- Manufacturing ISO 9001 Certified
- Agency Approvals cULus Listed

Operation

The CS-610-200 current switch monitors line current for electrical loads such as pumps, conveyors, machine tools or fans and closes the output contacts when the adjustable trip point is exceeded. The power LED lights when line current is detected and is below the setpoint. The status LED lights when line current exceeds the setpoint and the switch closes. It is typically used to monitor motor operation and can be used to determine on/off status, proof of operation, motor failure or belt loss.

The sensor requires no external power as it is totally powered by induction from the AC line being monitored. The trip setpoint is factory set to the minimum value (1 Amp) but can be set up to 200 Amps by rotating the adjustment pot counter-clockwise.

Motor current with trip point set to detect a broken belt

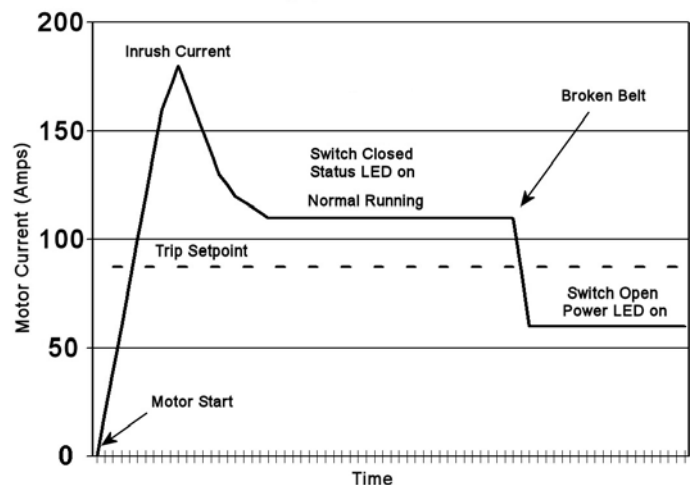

Installation

- Read all warnings before beginning
- Ensure the selected device has the correct ratings
- Disconnect and lock out power
- Mount the sensor with two screws through the base or snap onto a standard DIN mounting rail
- Place the monitored conductor through the sensor hole
- Wire the output to the controller (not polarity sensitive)
- Reconnect the power
- Calibrate the switch with the motor running normally

Dimensions

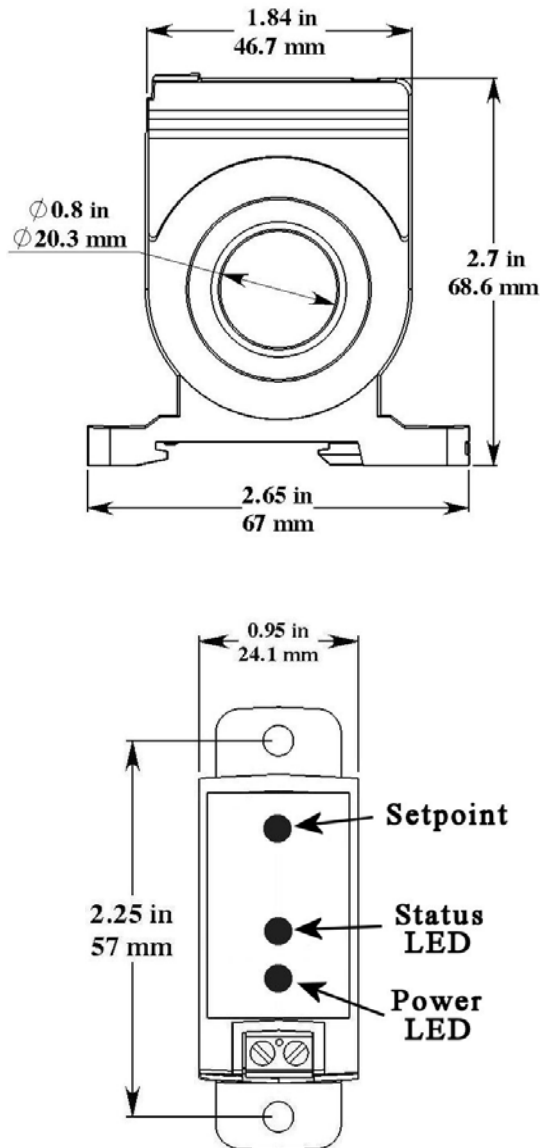

Calibration

With the sensor installed, turn on the monitored load (motor, heater, etc.) and allow it to run normally. Since the CS is factory set to switch at 1 Amp the status LED should be lit and the contacts should be closed if the load draws more than 1 Amp. Using a small screwdriver, rotate the multi-turn setpoint control counter-clockwise until the status LED turns off. Then slowly turn the knob clockwise until the status LED just comes on. Turn clockwise slightly more to eliminate false switching. The CS is now set to detect an under-current condition. A voltmeter can be used across the contacts to verify switch operation.

Wiring

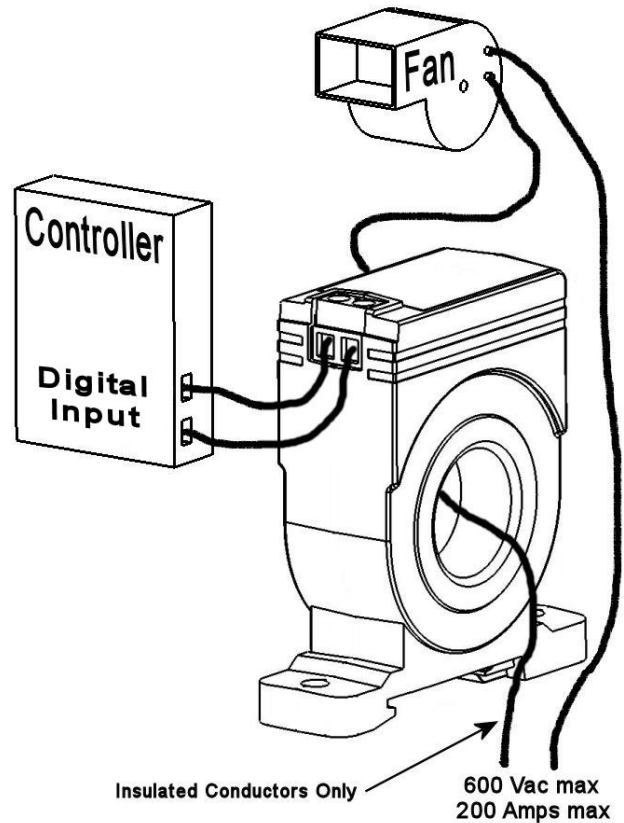

Applications

For applications with load currents exceeding the sensor current range use an external CT to reduce the current to an acceptable value. For example, to monitor a 500 Amp load current, use a 500A:5A CT and wrap the CT secondary through the CS-610-200 four times so the sensor actually only sees 20 Amps when the load current is 500 Amps.

For applications with very small load currents (such as less than 1 Amp), wrap the monitored conductor through the sensor aperture several times to increase the current measured by the sensor. For example, to monitor a 0-1 Amp load with a CS-610-200, wrap the conductor through the sensor aperture 5 times so the sensor actually sees 0-5 Amps.

For any application with multiple wraps, note that the CS-610-200 maximum current rating must be divided by the number of wraps. For example, with one wrap the maximum current is 200 Amps, with 5 wraps the maximum current is $200/5 = 40$ Amps. Ensure the load current is < 40 Amps or the device may overheat and be damaged.