



Introduction

The differential pressure transmitter is designed with dual sensors that enables it to accept high pressure ranges of 5 PSI to 500 PSI. All models can handle overload pressure 2X the maximum full scale range and burst pressure is 5X the maximum full scale range.

Features include field selectable pressure ranges and output signal types, output reversal and slow damping, port swapping and bidirectional measurements for the most flexible applications. The output signal is factory calibrated and temperature compensated for the highest start-up accuracy.

WARNING: Ensure that the maximum individual port pressure does not exceed the highest pressure range of the unit. For example, the highest individual port pressure on a WP-D-102 is 100 PSI. Exceeding this may damage the sensors and WILL give erroneous readings. See Figure 9 for ratings.

Before Installation

Read these instructions carefully before installing and commissioning the DP transmitter. Failure to follow these instructions may result in product damage. Do not use in an explosive or hazardous environment, with combustible or flammable gases, as a safety or emergency stop device or in any other application where failure of the product could result in personal injury. Take electrostatic discharge precautions during installation and do not exceed the device ratings.

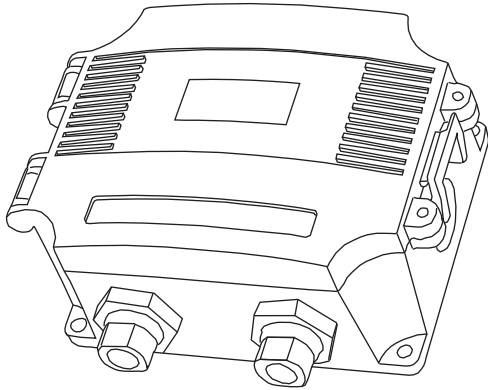

Mounting

The DP transmitter mounts on a vertical surface with the pressure ports on the bottom using the four mounting holes on the base of the unit. The four mounting holes will facilitate a #10 size screw (not supplied). See Figure 1. Ensure there is enough space around the unit to make the pressure and electrical connections. Avoid locations with severe vibrations or excessive moisture. The enclosure has a standard opening for a conduit connector or cable gland type fitting. **In this position the High port is on the left and the Low port is on the right as shown on the PCB.**

The enclosure has a hinged cover with latch. Open the cover by pulling slightly on the latch on the right side of the enclosure and at the same time pulling on the cover, as illustrated in Figure 2.

A 21 mm (0.8125") hole is provided for connection of either a 1/2" conduit connector or a cable gland style connector. Insert the conduit or cable gland connector through the hole and securely fasten using a locknut as shown in Figure 3.

Two security screws are provided which can be installed to help secure the cover once settings and wiring connections are complete. See Figure 4.

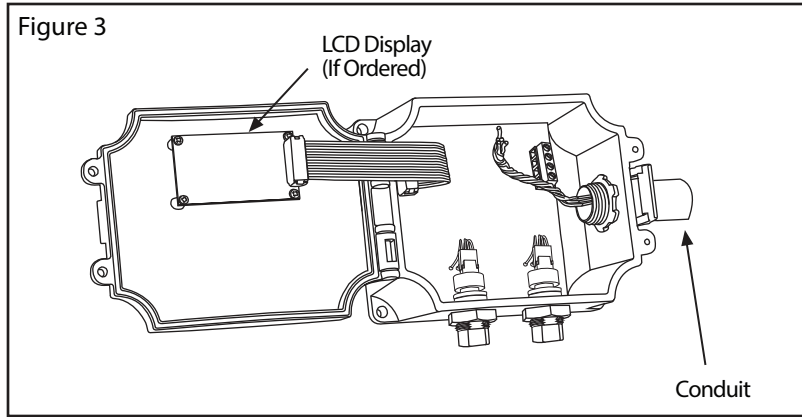
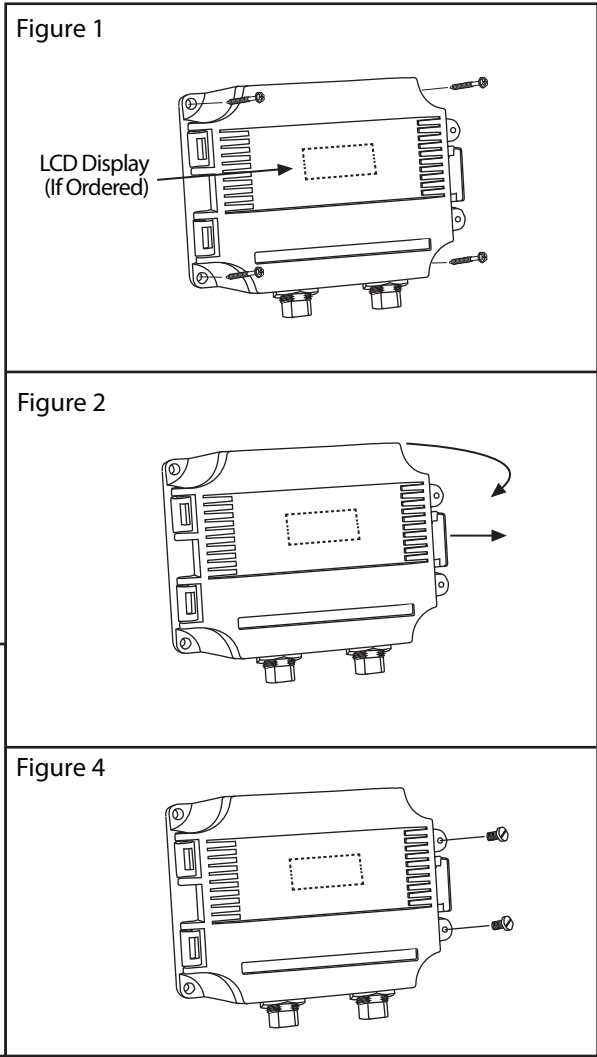

Plumbing

The two S/S pressure ports are labeled High and Low. The output signal indicates a positive value when the pressure is higher on the High port than the Low port so ensure these ports are connected correctly. Both ports accept a 1/8" NPT male fitting. Use appropriately rated pressure tubing and arrange it to minimize stress on the connections. Do not allow material to fall into the pressure ports as contamination could damage the sensors. It is recommended to use teflon tape to prevent leaks.

Wrap 1/8" NPT male fittings with teflon tape. Screw into the port on the pressure sensor until finger tight. Using an appropriate size wrench, tighten the fitting until snug as shown in Figure 5. Repeat for the second port.

Configuration

As shown on the drawing in Figure 6, several DIP switches are used to select the output signal type, the input pressure range and features that include Backlight on/off, bidirectional operation, port swap, slow damping and analog reverse functions.

WARNING: The DP transmitter must NOT have powered applied during set up or when making changes to the Output signal.

OUTPUT SELECTION: The DP transmitter comes with user-selectable outputs of 4-20 mA, 0-5 Vdc and 0-10 Vdc. **It is factory configured to operate in the CURRENT (4-20 mA output) mode**, but can be changed to VOLTAGE mode by sliding the output selection switch from the position marked CURRENT to the position marked VOLTAGE as shown in Figure 7.

In VOLTAGE mode the output scale may be changed to either 0-5 or 0-10 Vdc by moving the DIP switch to the 10V or 5V position as shown in Figure 8. **The factory default is 10V.**

If CURRENT mode was selected, DIP switch position in Figure 8 is not applicable.

RANGE SELECTION: Each model of the DP transmitter includes four pressure ranges to select from. The input pressure range is set by moving one of the 4 DIP switches to the on position as shown in Figure 9.

The factory default for every model is Range 1.

The model number is printed on a label showing the available ranges for that model is adhered to the inside of the enclosure.

FEATURES:

The factory default for all features is OFF except the Backlight if LCD is ordered. Backlight default is ON. See Figure 10.

BACKLIGHT ON: If the DP transmitter was ordered with the LCD option, this switch can be used to turn the backlight on/off. The backlight is enabled in the ON position but can be set to OFF to reduce power consumption.

Figure 5

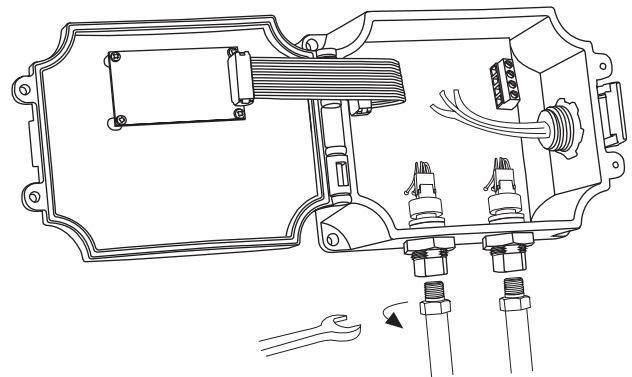

Figure 6

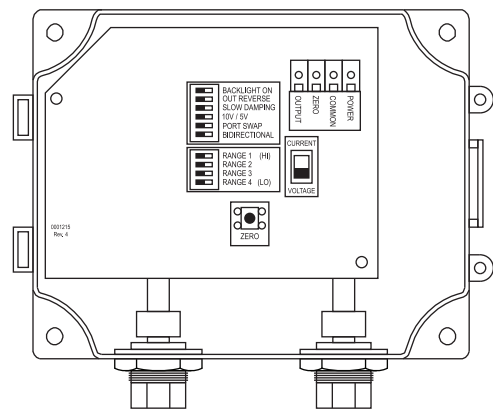

Figure 7

Output Type Selection



Factory default is CURRENT

Figure 8

Output Voltage Span Selection

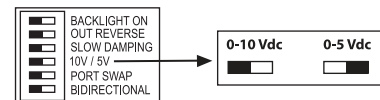

Factory Default is 0-10 Vdc

Figure 9

Pressure Range Selection

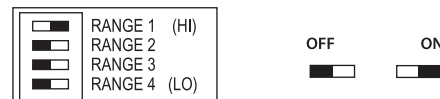

Model	Pressure Ranges (All ranges are 0 - XX)			
	1	2	3	4
101	50 PSI	25 PSI	10 PSI	5 PSI
102	100 PSI	50 PSI	20 PSI	10 PSI
103	200 PSI	100 PSI	40 PSI	20 PSI
104	500 PSI	250 PSI	100 PSI	50 PSI
105	5.0 Bar	2.5 Bar	1.0 Bar	0.5 Bar
106	7.5 Bar	3.75 Bar	1.50 Bar	0.75 Bar
107	10 Bar	5 Bar	2 Bar	1 Bar
108	30 Bar	15 Bar	6 Bar	3 Bar
109	500kPa	250 kPa	100 kPa	50 kPa
110	750 kPa	375 kPa	150 kPa	75 kPa
111	1000 kPa	500 kPa	200 kPa	100 kPa
112	3000 kPa	1500 kPa	600 kPa	300 kPa

Factory default for all models is Range 1

Configuration continued

OUTPUT REVERSE: This switch reverses the output signal polarity. In reverse mode the analog output is maximum when the pressure differential is zero and decreases as pressure increases.

SLOW DAMPING: This switch provides an 8-second averaging for surge dampening (normally it is 4-seconds).

PORT SWAP: This switch reverses the polarity of the pressure ports. It makes the HIGH port "low" and the LOW port "high". This is useful to correct plumbing errors.

BI-DIRECTIONAL: This switch changes the range from 0 to full scale differential pressure to minus full scale to plus full scale differential pressure. The analog output will read 1/2 when the differential pressure is zero. The example shown in Figure 11 shows the results when a Model 102 (0 to 100 psi) is operated in bi-directional mode (-100 to 100 psi).

To turn any of these features on slide the appropriate DIP switch to the ON position as shown in Figure 10.

Wiring

- Deactivate the 24 Vac/dc power supply until all connections are made to the device to prevent electrical shock or equipment damage.
- Use 14-22 AWG shielded wiring for all connections and do not locate the device wires in the same conduit with wiring used to supply inductive loads such as motors. Make all connections in accordance with national and local codes.
- Pull at least six inches of wire into the enclosure, then complete the wiring connection according to the wire diagram for the applicable power supply and output signal type.
- Connect the plus DC or the AC voltage hot side to the POWER terminal. For voltage output or AC power, the supply Common is connected to the COMMON terminal. **DO NOT connect power to the OUTPUT terminal as the device will be damaged.** It has a half-wave power supply so the supply Common is the same as the signal Common. See Figure 12.
- The analog output is available on the OUTPUT terminal. Check the controller Analog Input to determine the proper connection before applying power.
- If using the Zero function, connect the Remote Zero Switch between the ZERO and COMMON terminals.

Figure 10

Factory default for all settings is Off except Backlight
LCD Backlight factory default is ON

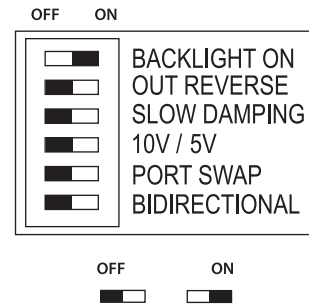
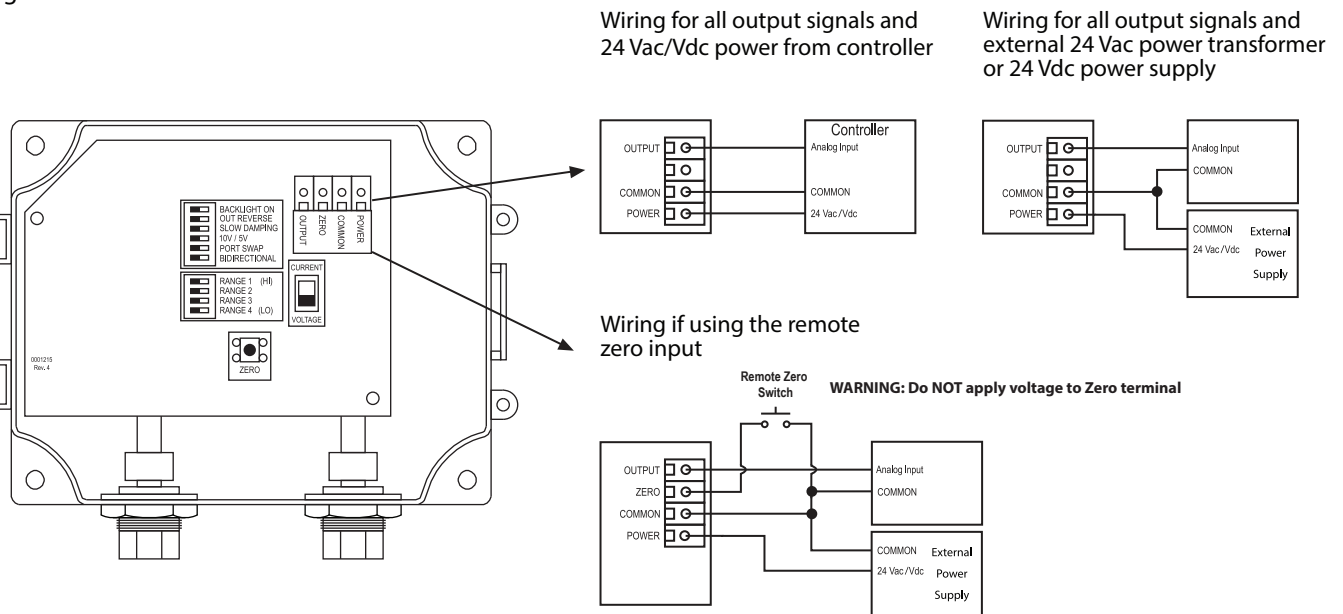

Figure 11

Bidirectional Output Readings

HIGH port	LOW port	LCD	4-20 mA	0-5 V
100 PSI	50 PSI	50 PSI	16 mA	3.75 V
50 PSI	100 PSI	-50 PSI	8 mA	1.25 V
50 PSI	50 PSI	0 PSI	12 mA	2.5 V
100 PSI	0 PSI	100 PSI	20 mA	5 V

Figure 12



Operation:

For normal operation such as 0-100 PSI, the pressure applied to the High port must be higher than the pressure applied to the Low port. If the pressure connection is reversed then the transmitter will always output 4 mA. If the Low port is left open to ambient pressure, then the High port is used to measure a positive pressure and 0 PSI = 4 mA and 100 PSI = 20 mA.

For bi-directional operation such as +/-100 PSI, the pressure applied to the High port should be higher than the pressure applied to the Low port for a positive output response. Negative pressure is indicated if the High pressure is less than the Low pressure. In this case -100 PSI = 4 mA and +100 PSI = 20 mA. Since the transmitter is linear 0 PSI = 12 mA.

Calibration:

With both ports open to the ambient pressure (or with both ports equalized at 0 pressure), press and hold the auto-zero button or provide contact closure on the ZERO terminals for at least 3 seconds. See Figure 12. Release the button or terminals and the device will calculate and store the new zero point. To protect the unit from accidental zeroing this feature is enabled only when the detected pressure on both ports is less than 5% of the full range. It is not recommended that the span calibration be performed in the field unless a high quality calibrator is available.

Specifications:

Media Compatibility:.....	17-4 PH stainless steel	Stability:.....	±0.25% F.S. typical (1 year)
Pressure Ranges:.....	4 switch selectable ranges per model. See Figure9	Zero Adjust:.....	Push-button auto-zero and digital input
Line Pressure:.....	Max. line pressure is the highest of the selectable ranges on each model	Power Supply:.....	24 Vac/Vdc ±10% (non-isolated half-wave rectified)
Proof Pressure:.....	Max. 2X highest range per model	Consumption:.....	75 mA max @ 24 Vdc
Burst Pressure:.....	Max. 5X highest range per model	Output Signal:.....	3-wire transmitter; 4-20mA (sourcing), 0-5/0-10 Vdc.
Accuracy:.....	± 1% F.S. of range selected (Range 4 is ± 2% F.S.)	Pressure Connections:.....	1/8" NPT female
Pressure Cycles:.....	>100 million	Enclosure:.....	ABS, hinged lid with gasket, IP65 (NEMA 4X)
Surge Damping:.....	Normal: 4 second averaging Slow: 8 second averaging, switch selectable	Dimensions:.....	145 X 100 X 64 mm (5.7" X 3.95" X 2.5")
Sensor Operating Range:.....	-40° to 85°C (-40° to 185°F)	Wiring Connections:.....	Screw terminal block (14 to 22 AWG)
Operating Environment:.....	0° to 50°C (32° to 122°F), 10-90% RH non-condensing	Optional LCD Display:.....	35 mm x 15 mm (1.4" w x 0.6" h) alpha-numeric 2 line x 8 character

Dimensions:

