

**Introduction**

The single point remote probe strap-on temperature thermostat incorporates a precision thermistor temperature sensor and provides a Form C relay output (NO/NC) with an adjustable setpoint. The sensor is encapsulated in a 6.35 mm (0.25") OD, 304 stainless steel probe and is available in various lengths. All probes provide excellent heat transfer, fast response and resist moisture penetration. Two enclosure styles are available.

**Before Installation**

Read these instructions carefully before installing and commissioning the temperature thermostat. Failure to follow these instructions may result in product damage. Do not use in an explosive or hazardous environment, with combustible or flammable gases, as a safety or emergency stop device or in any other application where failure of the product could result in personal injury. **Take electrostatic discharge precautions during installation and do not exceed the device ratings.**

**Mounting (Probe)**

The strap-on sensor installs directly onto any pipe where an immersion sensor with thermowell can't be installed.

Once a suitable spot is selected, remove a small section of insulation if present and set aside. It is recommended that thermal compound be used to improve heat transfer. Spread a liberal amount on the pipe. Lay probe in thermal compound and secure sensor to pipe using a worm gear clamp (not included).

For added protection it is recommended to wrap probe cable around pipe 1-2 times. Re-install insulation if present, allowing sensor cable to protrude.

See Figure 1.

**Mounting (Enclosure A)**

Mount the enclosure on a flat surface in close proximity to the area where the probe is mounted on the pipe. Secure the enclosure with (2) #10 x 25 mm (1") self tapping screws (not provided). Using a Phillips screwdriver, remove the (2) screws, as shown in Figure 2. Remove cover and set aside with screws for re-installing after wiring and set up.

A 21 mm (0.8125") hole provided for connection to a 12.77mm (0.5") EMT or cable gland style connector. Insert the EMT or cable gland connector through the hole and securely fasten using a locknut as shown in Figure 6. Make wire connections as per the "Wiring" illustrations on Page 4.

Once wiring and set up are complete, re-install cover and tighten the (2) screws using a Phillips screwdriver.

Figure 1

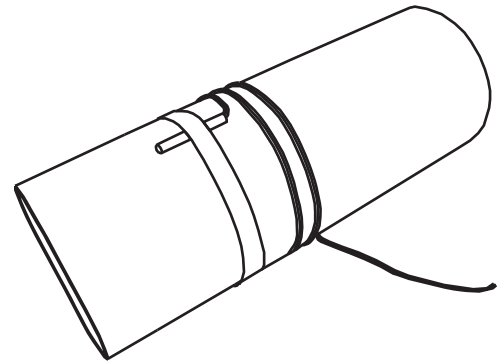

Figure 2

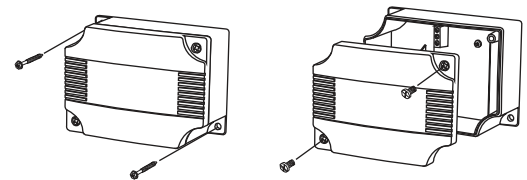

Figure 3

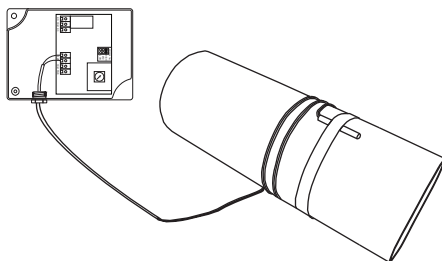
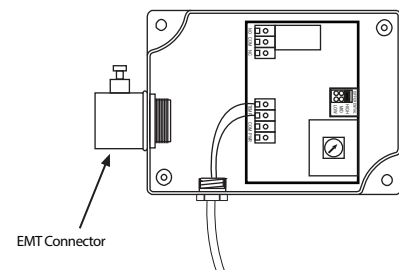
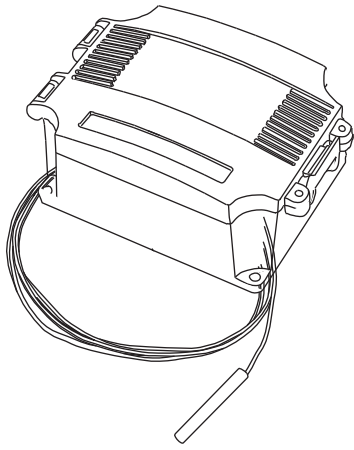

Figure 4





**Mounting (Enclosure D)**

Mount the enclosure on a flat surface in close proximity to the area where the probe inserted in the pipe. Secure the enclosure with (2) #10 x 25 mm (1") self tapping screws (not provided), as shown in Figure 5.

The enclosure has a hinged cover with latch. Open cover by pulling slightly on the latch on the right side of the enclosure. At the same time pulling on the cover, as shown in Figure 6.

A 21 mm (0.8125") hole provided for connection to a 12.77mm (0.5") EMT or cable gland style connector. Insert the EMT or cable gland connector through the hole and securely fasten using a locknut as shown in Figure 8.

Make wire connections as per the "Wiring" illustrations on Page 3.

Swing door closed until securely latched. For added security, 2 screws are provided that may be installed in the integrated screw tabs. See Figure 9.

Figure 5

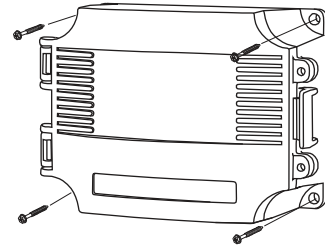

Figure 6

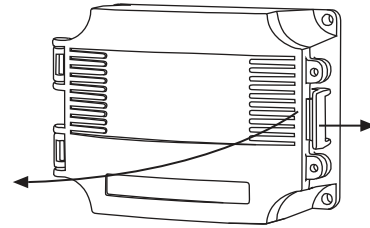

Figure 7

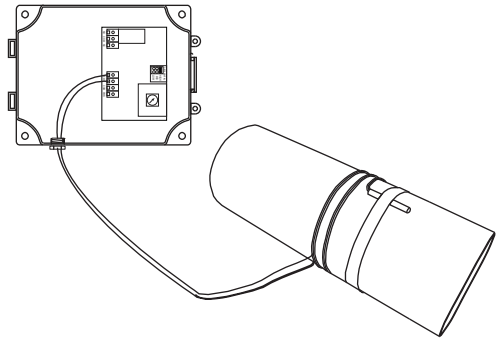

Figure 8

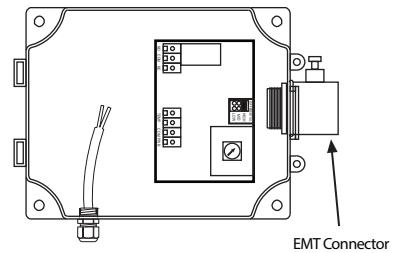
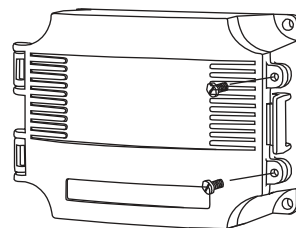
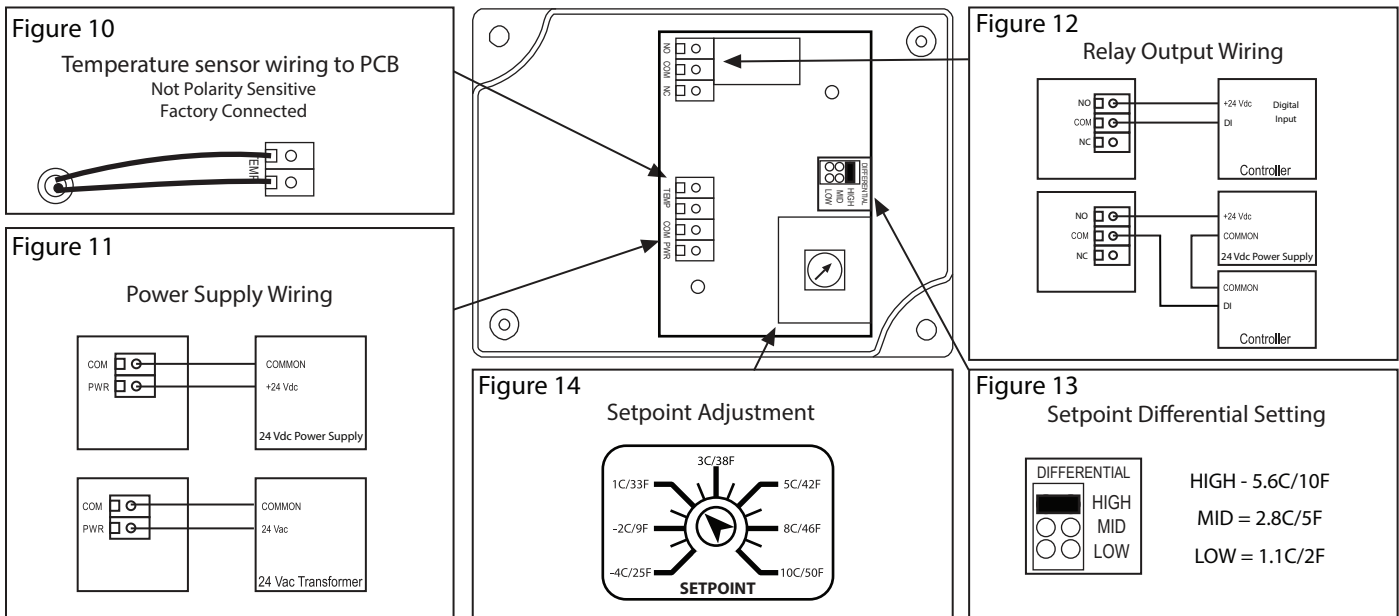

Figure 9



## Wiring

- Deactivate the 24 Vac/dc power supply until all connections are made to the device to prevent electrical shock or equipment damage.
- Use 14-22 AWG shielded wiring for all connections and do not locate the device wires in the same conduit with wiring used to supply inductive loads such as motors. Make all connections in accordance with national and local codes.
- The sensor is factory connected. If there is a need to remove and re-connect, connect the the terminals on the PCB marked TEMP. as shown in Figure 10 The temperature sensor is not polarity sensitive.
- Pull at least six inches of control wire into the enclosure, then complete the wiring connection according to the wire diagram for the applicable power supply as shown in Figure 11.
- Connect the DC positive or the AC voltage hot side to the PWR terminal. The supply common is connected to the COM terminal. See Figure 12.
- The relay has both Normally Open (NO) and Normally Closed (NC) contacts available. The relay output is available on the NO/COM/NC terminal. Make connections before applying power as shown in Figure 13.
- The setpoint differential has 3 jumper selectable settings (Low/Mid/High) Set jumper to desired differential as shown in Figure 16.
- To set the switching setpoint, turn the setpoint potentiometer to the desired temperature setting as shown in Figure 14.
- Once all connections settings are made and checked, power can be applied.



## Specification:

Power Supply	12 to 28 Vac/dc
Consumption	50 mA max
Relay Contacts	SPDT, Form C contacts (N.O. and N.C.) 5 Amps @ 30 Vdc/250 Vac resistive 1.5 Amps @ 30 Vdc/250 Vac inductive
Relay Action	Activates on temperature fall
Setpoint Operation	Single-turn knob-pot on pcb
Adjustable Setpoint	-4 to 10°C (25 to 50°F)
Setpoint Temperature	Low/Mid/High jumper selectable
Differential	1.1/2.8/5.6 °C (2/5/10 °F)
Temperature Sensor	10K ohm curve matched precision thermistor
Sensor Accuracy	±0.2°C, 0 to 70°C (±0.36°F, 32 to 158°F)
Probe Sensing Range	-20 to 105°C (-4 to 221°F)
Probe Material	304 Series Stainless Steel

Probe Diameter	0.25" (6.35 mm) Diameter
Probe Lengths	50, 100, 150 or 200 mm (2", 4", 6" or 8")
Wire Material	PVC insulated, Parallel bonded
Wire Length	1.524 m (5')
Operating Conditions	-10 to 50°C (14 to 122°F), 5 to 95% RH non-condensing
Storage Conditions	-30 to 70°C (-22 to 158°F), 5 to 95%RH, non-condensing
Enclosure	(A) ABS, UL94-5VB, IP61 (NEMA 2) (D)-ABS, UL94-5VB, IP65 (NEMA 4X)
Wiring Connections	Screw terminal block (14 to 22 AWG)

**Dimensions:**

Enclosure A

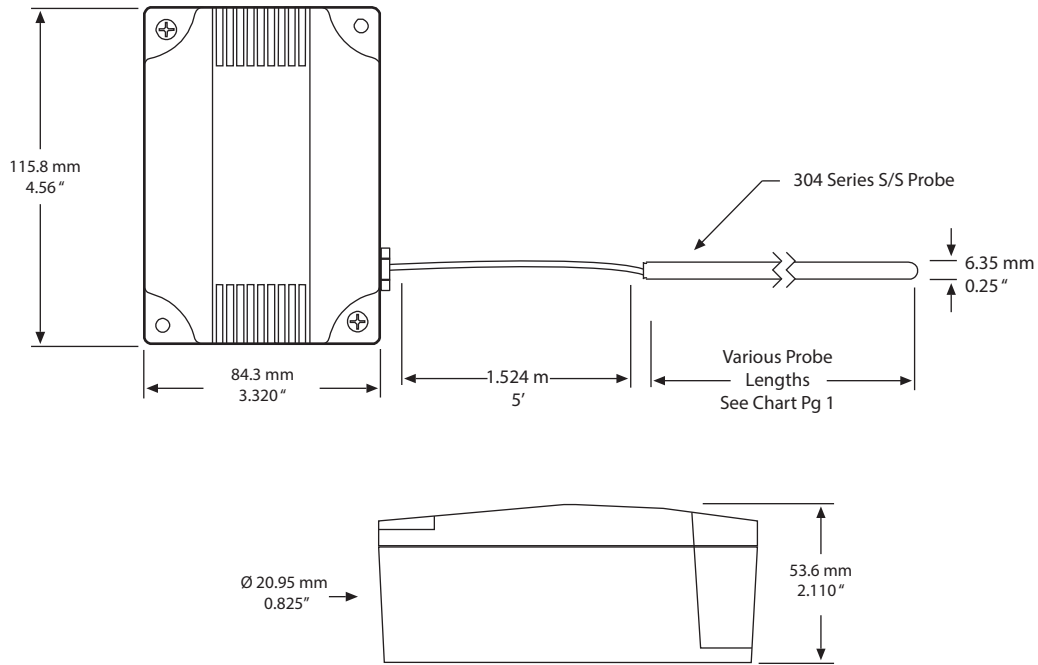

Enclosure D

