

Introduction

The TTLOS, single point outside air temperature thermostat incorporates a precision thermistor temperature sensor and provides a Form C relay output (NO/NC) with an adjustable setpoint. All probes are constructed to provide excellent heat transfer, fast response and are potted to resist moisture penetration. A sun and wind shield is integrated into a weatherproof ABS enclosure

Before Installation

Read these instructions carefully before installing and commissioning the RH transmitter. Failure to follow these instructions may result in product damage. Do not use in an explosive or hazardous environment, with combustible or flammable gases, as a safety or emergency stop device or in any other application where failure of the product could result in personal injury. Take electrostatic discharge precautions during installation and do not exceed the device ratings.

Mounting

Select a suitable mounting spot on an exterior wall where the TTLOS is best protected from direct exposure to sunlight, wind, etc. preferably on a north facing wall. Do not mount the sensor near opening windows, supply/exhaust air louvres or other known air disturbances. Avoid areas where the sensor is exposed to vibrations or rapid temperature changes.

The TTLOS provides a connection hole for 1/2" Conduit. Run a length of conduit through exterior wall and seal. Use 14-22 AWG shielded wiring for all connections and do not locate the device wires in the same conduit with wiring used to supply inductive loads such as motors. Make all connections in accordance with national and local codes.

The TTLOS sensor installs directly on an exterior wall using the four integrated mounting holes are provided on the enclosure. Select the best mounting technic based on the exterior wall material. The 4 mounting holes will facilitate a #10 size screw (Not supplied). The sensor fitting must be pointing down. See Figure 1.

The enclosure has a hinged cover with latch. Open cover by pulling slightly on the latch on the right side of the enclosure. At the same time pulling on the cover, as illustrated in Figure 2.

Feed conduit through the provided hole in bottom of enclosure and secure with a lock nut as show in Figure 3. It is recommended that weatherproof conduit or cable gland fittings be used.

Make wiring connections as per the "Wiring" illustrations on Page 2.

Swing door closed until securely latched. For added security, 2 screws are provided that may be installed in the integrated screw tabs. See Figure 4.

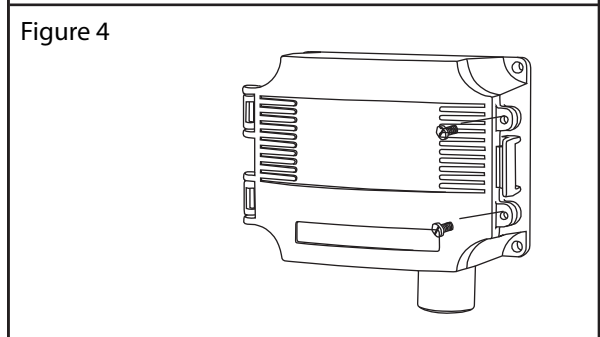
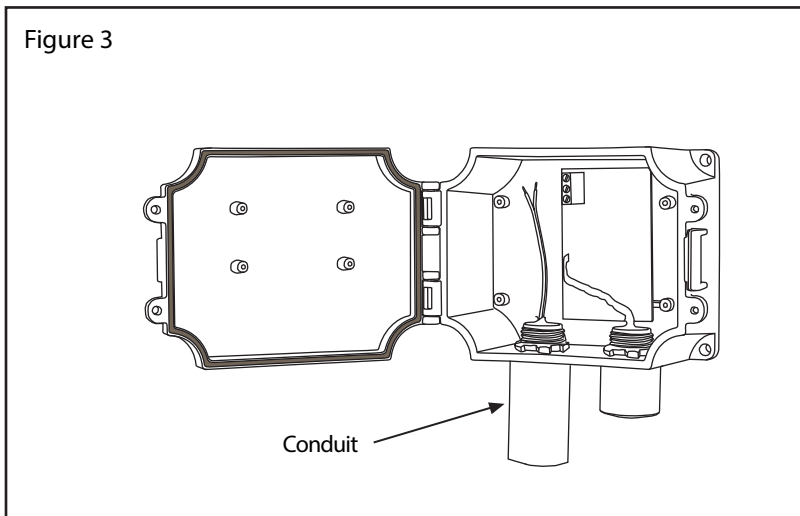
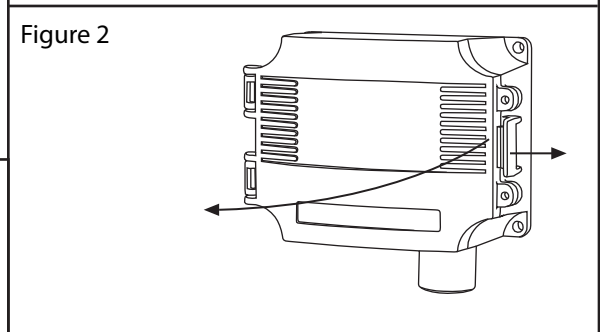
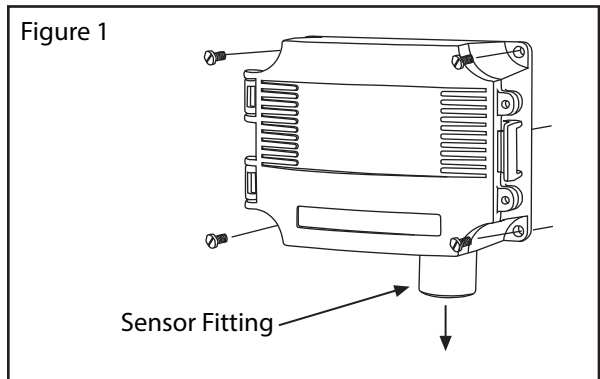

Wiring

- Deactivate the 24 Vac/dc power supply until all connections are made to the device to prevent electrical shock or equipment damage.
- Use 14-22 AWG shielded wiring for all connections and do not locate the device wires in the same conduit with wiring used to supply inductive loads such as motors. Make all connections in accordance with national and local codes.
- The temperature thermostat comes with the temperature sensor pre-wired to the PCB. If removal is required for installation then it may be re-wired as shown in Figure 5.
- Pull at least six inches of control wire into the enclosure, then complete the wiring connection according to the wire diagram for the applicable power supply as shown in Figure 6.
- Connect the DC positive or the AC voltage hot side to the PWR terminal. The supply common is connected to the COM terminal. See Figure 6.
- The relay has both Normally Open (NO) and Normally Closed (NC) contacts available. The relay output is available on the NO/COM/NC terminal. Make connections before applying power as shown in Figure 7.
- The setpoint differential has 3 jumper selectable settings (Low/Mid/High) Set jumper to desired differential as shown in Figure 8.
- To set the switching setpoint, turn the setpoint potentiometer to the desired temperature setting as shown in Figure 9.
- Once all connections settings are made and checked, power can be applied.

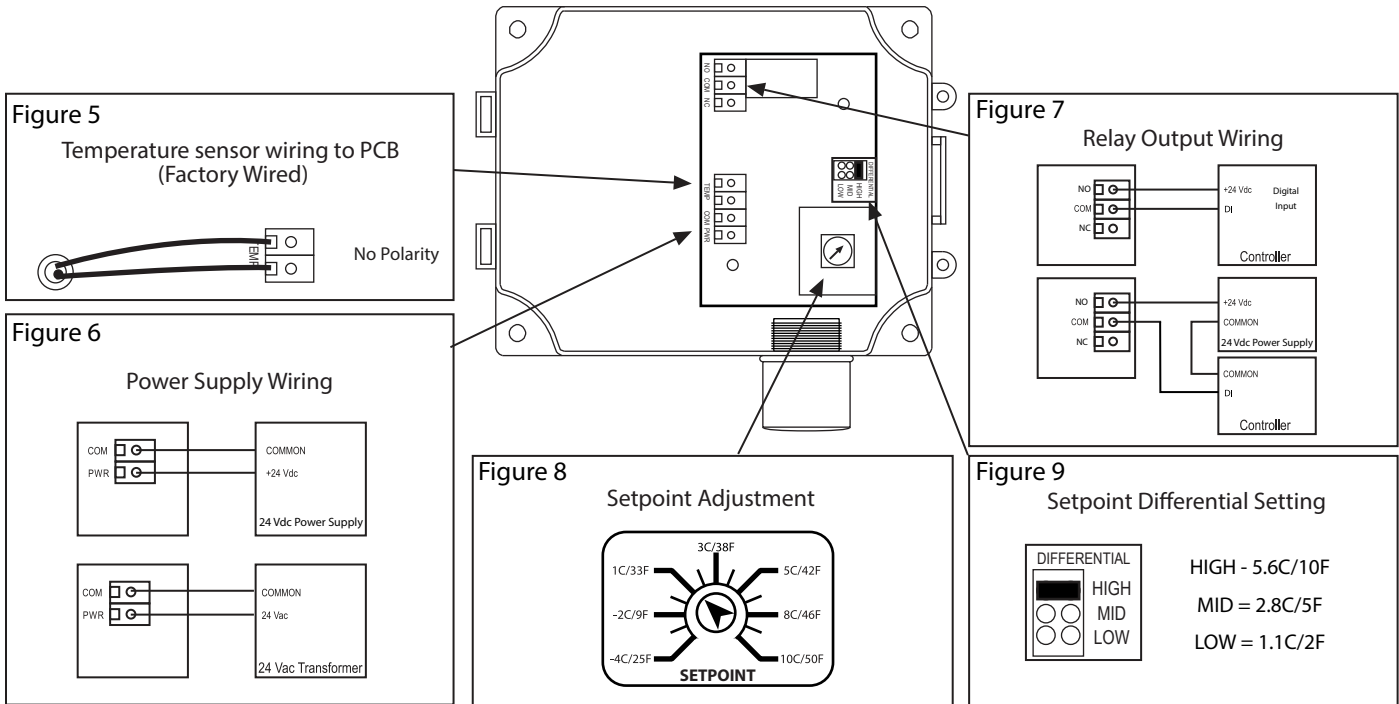

Specification:

Power Supply.....	12 to 28 Vac/dc
Consumption.....	50 mA max
Relay Contacts.....	SPDT, Form C contacts (N.O. and N.C.) 5 Amps @ 30 Vdc/250 Vac resistive 1.5 Amps @ 30 Vdc/250 Vac inductive
Relay Action.....	Activates on temperature fall
Setpoint Operation.....	Single-turn knob-pot on pcb
Adjustable Setpoint.....	-4 to 10°C (25 to 50°F)
Setpoint Temperature	Low/Mid/High jumper selectable
Differential	1.1/2.8/5.6°C (2/5/10 °F)
Temperature Sensor.....	10K ohm curve matched precision thermistor
Sensor Accuracy.....	±0.2°C (±0.36°F), 0 to 70°C (32 to 158°F)
Operating Conditions.....	-10 to 50°C (14 to 122°F), 5 to 95% RH non-condensing
Storage Conditions.....	-30 to 70°C (-22 to 158°F), 5 to 95%RH, non-condensing
Enclosure	ABS, UL94-5VB, IP65 (NEMA 4X)
Wiring Connections.....	Screw terminal block (14 to 22 AWG)

Dimensions:

