

Introduction

The single point immersion temperature thermostat incorporates a precision thermistor temperature sensor and provides a Form C relay output (NO/NC) with an adjustable setpoint. The sensor is encapsulated in a 6.35 mm (0.25") OD, 304 stainless steel probe and is available in various lengths. All probes provide excellent heat transfer, fast response and resist moisture penetration. Two enclosure styles are available.

Before Installation

Read these instructions carefully before installing and commissioning the temperature thermostat. Failure to follow these instructions may result in product damage. Do not use in an explosive or hazardous environment, with combustible or flammable gases, as a safety or emergency stop device or in any other application where failure of the product could result in personal injury. **Take electrostatic discharge precautions during installation and do not exceed the device ratings.**

Mounting

The immersion thermostat must be installed into a thermowell. Failure to use a thermowell will create leaks and could damage the sensor. It is provided in two pieces, probe and enclosure, which allows for easier installation. The probe has 1/2" NPT threaded fitting for mounting to the thermowell. Install the thermowell as recommended in Figure 1. For complete thermowell installation instructions, please refer to installation instructions provided with the thermowell.

It is recommended to use heat conductive compound. Prior to installing the sensor inject a liberal amount into the thermowell and/or on the tip of the sensor. Slide the probe into thermowell until the 1/2" NPT fitting makes contact with the thermowell. Tighten slightly by hand by turning clockwise. See Figure 2.

Using a 7/8" (23 mm) wrench, tighten the fitting into the thermowell until snug. To protect against overtightening and damaging the probe, the assembly is designed to allow the probe to slide inside the fitting. See Figure 3.

Mounting (Enclosure A)

Using a Phillips screwdriver, remove the (2) screws, as shown in Figure 4. Remove cover and set aside with screws for re-installing after wiring and set up.

Two 21 mm (0.8125") holes are provided one for connection to probe assembly and one for connection to either 12.77mm (0.5") EMT or a cable gland style connector. Insert probe wire in one of the connection holes and mount on probe fitting. Securely fasten using supplied locknut as shown in Figure 5.

Insert the EMT or cable gland connector through the hole and securely fasten using a locknut as shown in Figure 6. **Special care must be taken not to damage any internal components during installation.**

Make wire connections as per the "Wiring" illustrations on Page 3.

Once wiring and set up are complete, re-install cover and tighten the (2) screws using a Phillips screwdriver.

Figure 1

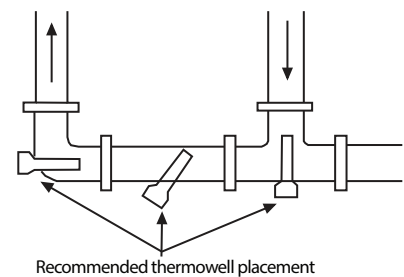

Figure 2

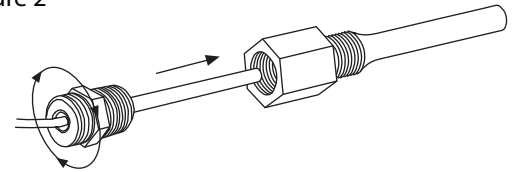

Figure 3

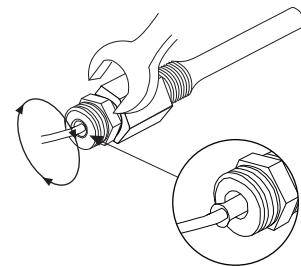

Figure 4

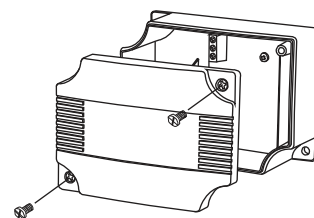

Figure 5

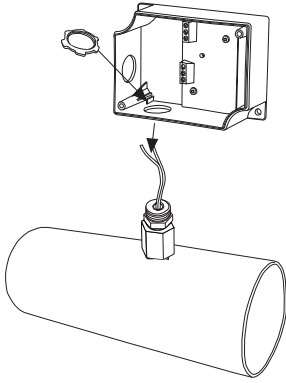

Figure 6

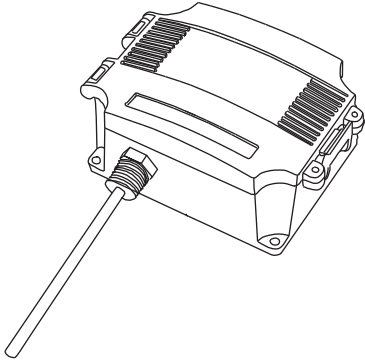
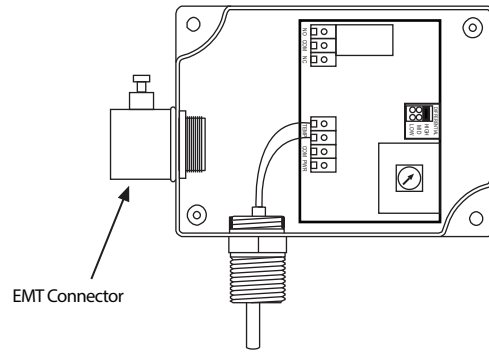

Figure 7

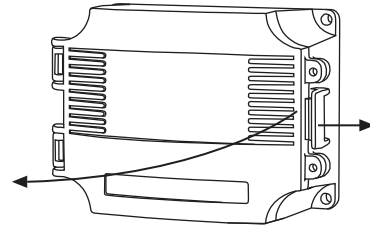
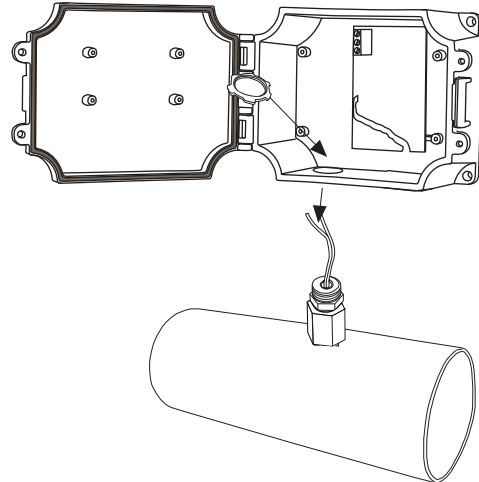

Figure 8



Mounting (Enclosure D)

The enclosure has a hinged cover with latch. Open cover by pulling slightly on the latch on the right side of the enclosure. At the same time pulling on the cover, as illustrated in Figure 7.

Two 21 mm (0.8125") holes are provided one for connection to probe assembly and one for connection to either 12.77mm (0.5") EMT or a cable gland style connector. Insert probe wire in one of the connection holes and mount on probe fitting. Securely fasten using supplied locknut as shown in Figure 8.

Insert the EMT or cable gland connector through the hole and securely fasten using a locknut as shown in Figure 9. **Special care must be taken not to damage any internal components during installation.**

Make wire connections as per the "Wiring" illustrations on Page 3.

Swing door closed until securely latched. For added security, 2 screws are provided that may be installed in the integrated screw tabs. See Figure 10.

Figure 9

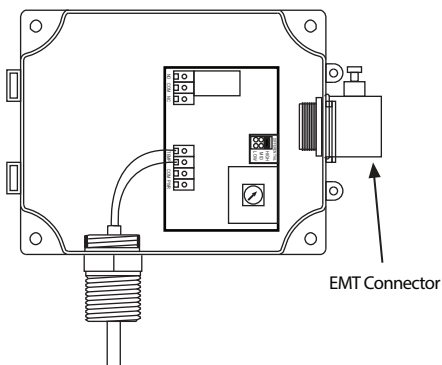
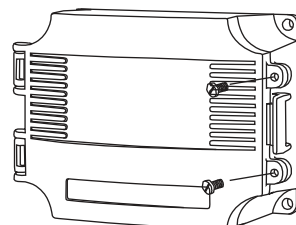
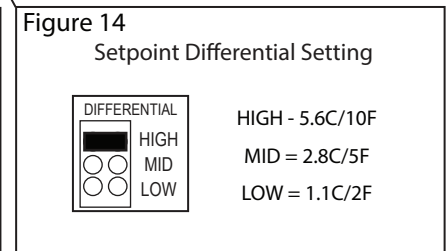
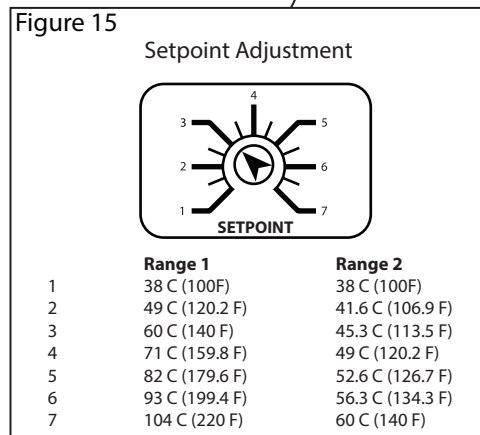
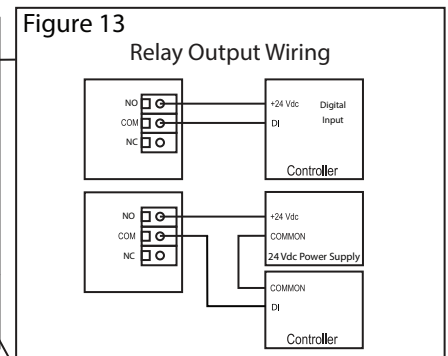
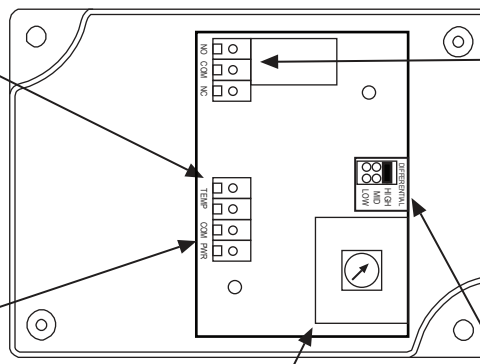
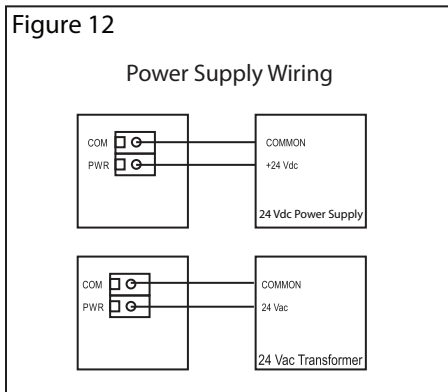
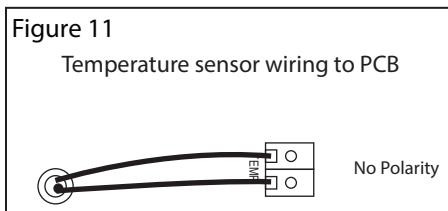

Figure 10



Wiring

- Deactivate the 24 Vac/dc power supply until all connections are made to the device to prevent electrical shock or equipment damage.
- Use 14-22 AWG shielded wiring for all connections and do not locate the device wires in the same conduit with wiring used to supply inductive loads such as motors. Make all connections in accordance with national and local codes.
- Connect the temperature sensor to the terminals on the PCB marked TEMP as shown in Figure 11. The temperature sensor is not polarity sensitive.
- Pull at least six inches of control wire into the enclosure, then complete the wiring connection according to the wire diagram for the applicable power supply as shown in Figure 12.
- Connect the DC positive or the AC voltage hot side to the PWR terminal. The supply common is connected to the COM terminal. See Figure 12.
- The relay has both Normally Open (NO) and Normally Closed (NC) contacts available. The relay output is available on the NO/COM/NC terminal. Make connections before applying power as shown in Figure 13.
- The setpoint differential has 3 jumper selectable settings (Low/Mid/High) Set jumper to desired differential as shown in Figure 14.
- To set the switching setpoint, turn the setpoint potentiometer to the desired temperature setting as shown in Figure 15.
- Once all connections settings are made and checked, power can be applied.



Specification:

| | |
|----------------------------|---|
| Power Supply..... | 12 to 28 Vac/dc |
| Consumption..... | 50 mA max |
| Relay Contacts..... | SPDT, Form C contacts (N.O. and N.C.) 5 Amps @ 30 Vdc/250 Vac resistive 1.5 Amps @ 30 Vdc/250 Vac inductive |
| Relay Action..... | Activates on temperature rise |
| Setpoint Operation..... | Single-turn knob-pot on pcb |
| Adjustable Setpoint..... | Range 1: 38 to 104 °C (100 to 220 °F) Range 2: 38 to 60 °C (100 to 140 °F) |
| Setpoint Temperature | Low/Mid/High jumper selectable |
| Differential | 1.1/2.8/5.6 °C (2/5/10 °F) |
| Temperature Sensor..... | 10K ohm curve matched precision thermistor |
| Sensor Accuracy..... | ±0.2°C, 0 to 70°C (±0.36°F, 32 to 158°F) |
| Probe Sensing Range | -20 to 105°C (-4 to 221°F) |

| | |
|----------------------------|---|
| Probe Material | 304 Series Stainless Steel |
| Probe Diameter..... | 0.25" (6.35 mm) Diameter |
| Probe Lengths | 50, 100, 150 or 200 mm (2", 4", 6" or 8") |
| Fitting Size | 1/2" NPT |
| Fitting Material | Brass or Nylon |
| Wire Material..... | PVC parallel-bonded |
| Operating Conditions | -10 to 50°C (14 to 122°F), 5 to 95% RH non-condensing |
| Storage Conditions..... | -30 to 70°C (-22 to 158°F), 5 to 95%RH, non-condensing |
| Enclosure..... | (A) ABS, UL94-5VB, IP61 (NEMA 2) (D)-ABS, UL94-5VB, IP65 (NEMA 4X) |
| Wiring Connections..... | Screw terminal block (14 to 22 AWG) |

Dimensions:

Enclosure A

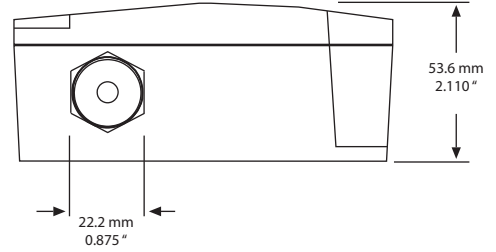
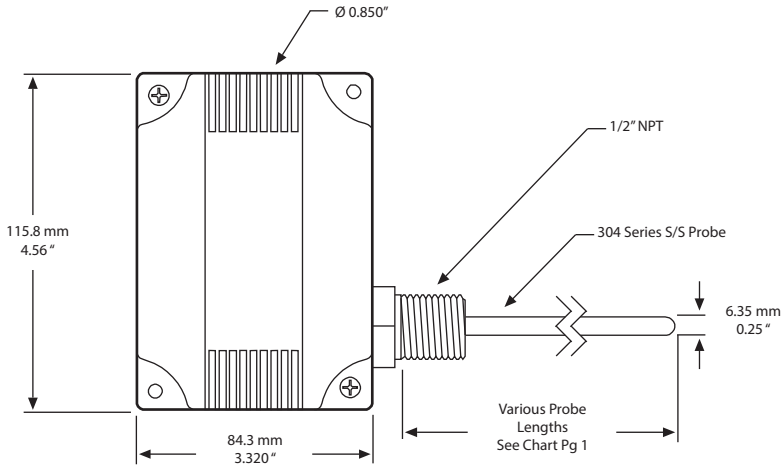

Enclosure D

