

Introduction

The RH series uses a highly accurate and reliable Thermoset Polymer based capacitance humidity sensor and Platinum RTD temperature sensor together with state-of-the-art digital linearization and temperature compensated circuitry to monitor humidity levels. A hinged, gasketed weatherproof ABS enclosure provides easy of installation and protection from the elements.

Before Installation

Read these instructions carefully before installing and commissioning the RH transmitter. Failure to follow these instructions may result in product damage. Do not use in an explosive or hazardous environment, with combustible or flammable gases, as a safety or emergency stop device or in any other application where failure of the product could result in personal injury. Take electrostatic discharge precautions during installation and do not exceed the device ratings.

Select a suitable mounting spot on an exterior wall where the sensor is best protected from direct exposure to sunlight, wind, etc. preferably on a north facing wall. Do not mount the sensor near opening windows, supply/exhaust air louvres or other known air disturbances. Avoid areas where the sensor is exposed to vibrations or rapid temperature changes.

The RH enclosure provides a connection hole for 1/2" Conduit. Run a length of conduit through exterior wall and seal. Use 14-22 AWG shielded wiring for all connections and do not locate the device wires in the same conduit with wiring used to supply inductive loads such as motors. Make all connections in accordance with national and local codes.

Mounting

The RH sensor installs directly on an exterior wall using the four integrated mounting holes are provided on the enclosure. Select the best mounting technic based on the exterior wall material. The 4 mounting holes will facilitate a #10 size screw (Not supplied). The sensor fitting must be pointing down. See **Figure 1**.

The enclosure has a hinged cover with latch. Open cover by pulling slightly on the latch on the right side of the enclosure. At the same time pulling on the cover, as illustrated in **Figure 2**.

Feed conduit through the provided hole in bottom of enclosure and secure with a lock nut as show in **Figure 3**. It is recommended that weatherproof conduit or cable gland fittings be used.

Make wiring connections as per the "Wiring" illustrations on Page 2.

Swing door closed until securely latched. For added security install the two supplied security screws as shown in **Figure 4**.

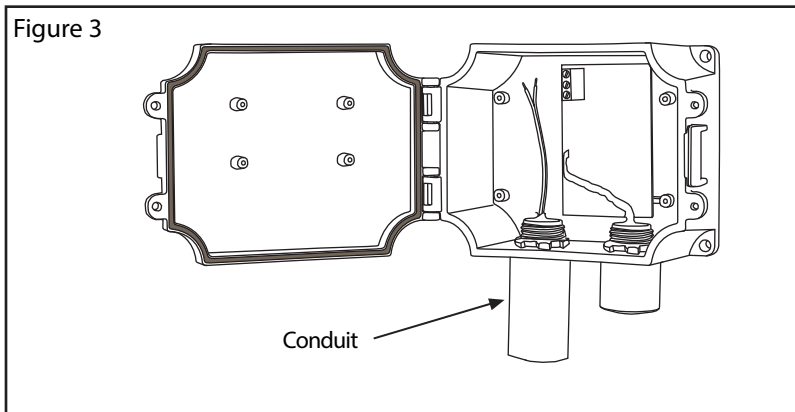
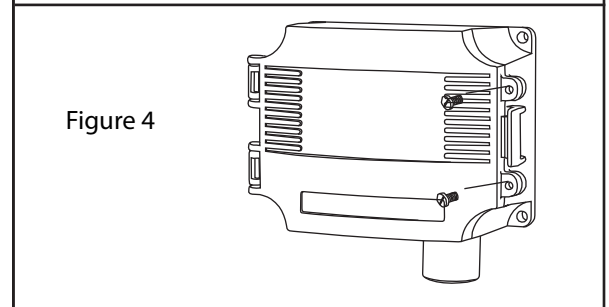
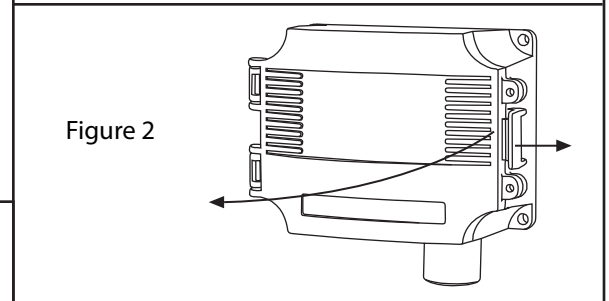
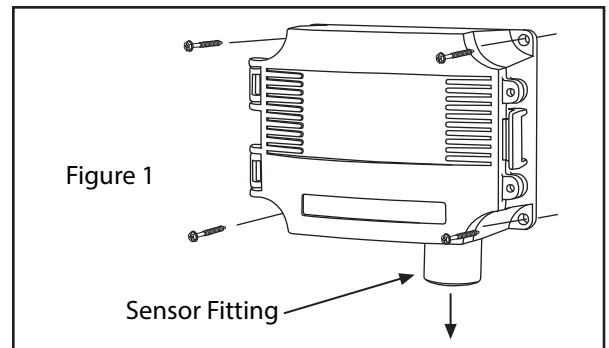

Wiring

- Deactivate the 24 Vac/dc power supply until all connections are made to the device to prevent electrical shock or equipment damage.
- Use 14-22 AWG shielded wiring for all connections and do not locate the device wires in the same conduit with wiring used to supply inductive loads such as motors. Make all connections in accordance with national and local codes.
- Pull at least six inches of wire into the enclosure, then complete the wiring connection according to the wiring diagram for the applicable power supply and output signal type.
- Connect the plus DC or the AC voltage hot side to the PWR terminal. For voltage output or AC power, the supply Common is connected to the COM terminal. The device is reverse voltage protected and will not operate if connected backwards. It has a half-wave power supply so the supply Common is the same as the signal Common. See **Figure 5**.
- The analog outputs are designated as TEMP and RH by each terminal. Check the controller Analog Input to determine the proper connection before applying power. See **Figure 5**.

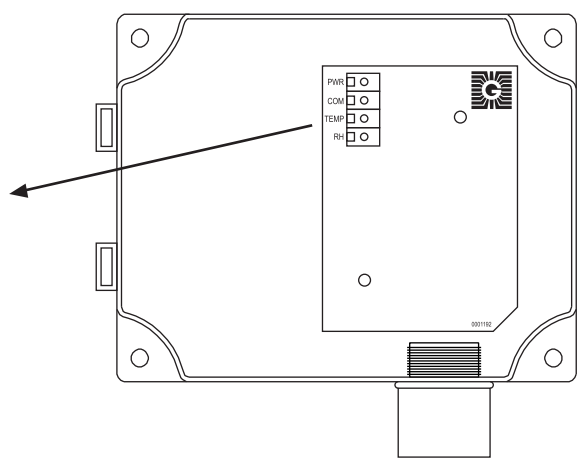
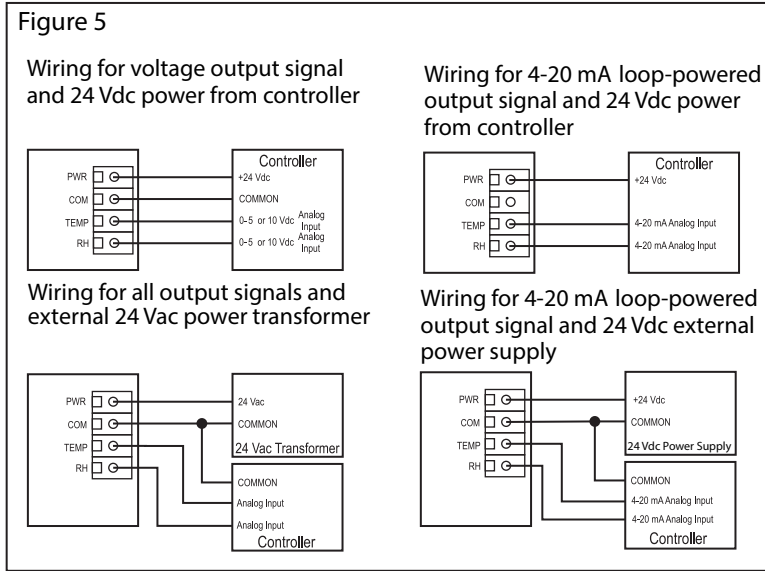

Specification:

Humidity Sensor Type:.....Thermoset polymer based capacitive
 Accuracy at 25°C:.....±2, 3, or 5% RH, (5% to 95% RH)
 Measurement Range:.....0 to 100% RH
 Hysteresis:.....±1.5% RH maximum
 Stability:.....±1% RH typical at 50% RH in 5 yrs.
 Sensor Response Time:.....15 seconds typical
 Temperature Sensor Type:.....1000 Ω Platinum. IEC751, 385 Alpha, thin film, Class B, ±0.3°C @ 0°C
 Operating Temperature:.....-40° to 70°C (-40° to 158°F)
 Operating Humidity:.....0 to 95% RH non-condensing
 Power Supply:.....18 to 30 Vdc, 15 to 26 Vac
 Consumption:.....40 mA maximum
 Input Voltage Effect:.....Negligible over specified operating range
 Protection Circuitry:.....Reverse voltage protected and output limited
 Output Signal:.....4-20 mA current loop, 0-5 or 0-10 Vdc
 Output Drive at 24 Vdc:.....550 ohms max for current output
 10K ohms min for voltage output
 Wiring Connections:.....Screw terminal block (14 to 22 AWG)
 Enclosures:.....ABS, UL94-V0, IP65 (NEMA 4X)

Dimensions:

