

Introduction

The RH300A series uses a highly accurate and reliable Thermoset Polymer based capacitance humidity sensor and state-of-the-art digital linearization and temperature compensated circuitry in an weatherproof enclosure to monitor outside humidity levels. Sensors are mounted in a sun and wind shield for more accurate monitoring. An optional temperature sensor is also available

Before Installation

Read these instructions carefully before installing and commissioning the RH transmitter. Failure to follow these instructions may result in product damage. Do not use in an explosive or hazardous environment, with combustible or flammable gases, as a safety or emergency stop device or in any other application where failure of the product could result in personal injury. Take electrostatic discharge precautions during installation and do not exceed the device ratings.

Select a suitable mounting spot on an exterior wall where the RH300A is best protected from direct exposure to sunlight, wind, etc. preferably on a north facing wall. Do not mount the sensor near opening windows, supply/exhaust air louvres or other known air disturbances. Avoid areas where the sensor is exposed to vibrations or rapid temperature changes.

The RH300A provides a connection hole for 1/2" Conduit. Run a length of conduit through exterior wall and seal. Use 14-22 AWG shielded wiring for all connections and do not locate the device wires in the same conduit with wiring used to supply inductive loads such as motors. Make all connections in accordance with national and local codes.

Mounting

The RH300A sensor installs directly on an exterior wall using the four integrated mounting holes are provided on the enclosure. Select the best mounting technic based on the exterior wall material. The 4 mounting holes will facilitate a #10 size screw (Not supplied). The sensor fitting must be pointing down. See Figure 1.

The RH300A enclosure has a hinged cover with latch. Open cover by pulling slightly on the latch on the right side of the enclosure. At the same time pulling on the cover, as illustrated in Figure 2.

Feed conduit through the provided hole in bottom of enclosure and secure with a lock nut as show in Figure 3. It is recommended that weatherproof conduit or cable gland fittings be used.

Make wiring connections as per the "Wiring" illustrations on Page 2.

Swing door closed until securely latched. For added security, 2 screws are provided that may be installed in the integrated screw tabs. See Figure 4.

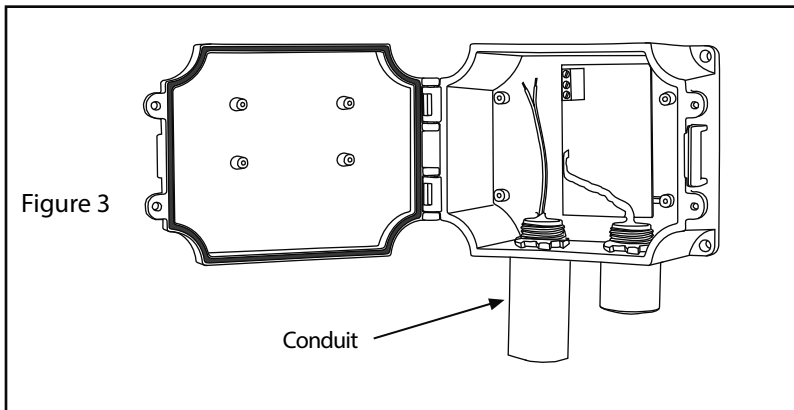
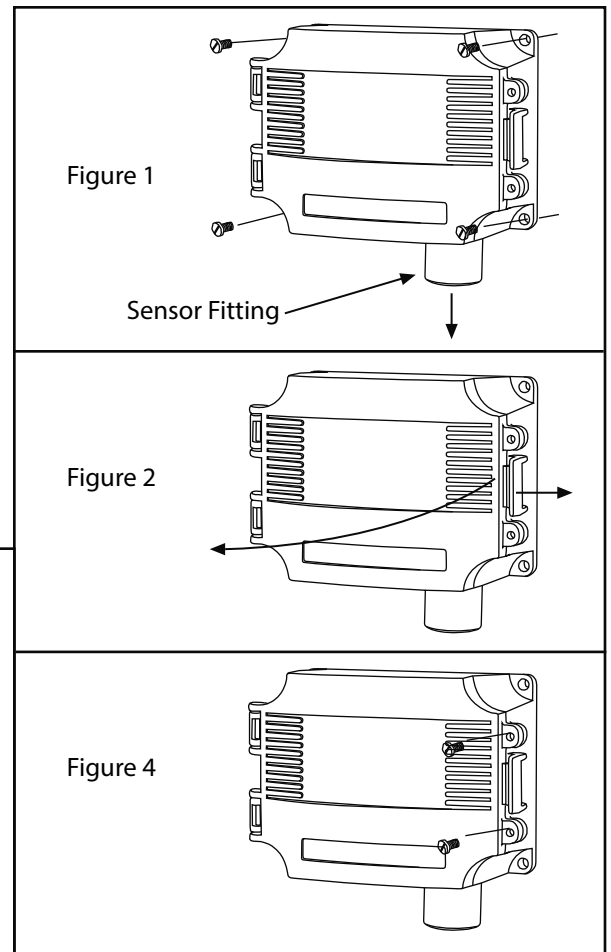

Wiring

- Deactivate the 24 Vac/dc power supply until all connections are made to the device to prevent electrical shock or equipment damage.
- Use 14-22 AWG shielded wiring for all connections and do not locate the device wires in the same conduit with wiring used to supply inductive loads such as motors. Make all connections in accordance with national and local codes.
- Pull at least six inches of wire through the wall and into the enclosure, then complete the wiring connection according to the wire diagram for the applicable power supply and output signal type.
- Select desired signal output type (mA or Vdc) by placing the output switch in required position, as shown in Figure 5. Factory default is mA (4-20 mA).
- If mA was selected, no further Output set up is required. If VOLT output is selected in Figure 5, place Voltage Output Jumper to desired span position, as shown in Figure 6. ie: 10 = 0-10 Vdc. Factory default is 10v = 0-10Vdc.
- Connect the plus DC or the AC voltage hot side to the PWR terminal. For voltage output or AC power, the supply Common is connected to the COM terminal. The device is reverse voltage protected and will not operate if connected backwards. It has a half-wave power supply so the supply Common is the same as the signal Common. See Figure 7.
- The analog output is available on the OUT terminal. Check the controller Analog Input to determine the proper connection before applying power. See Figure 7.
- If installed, the resistance temperature output is available on the two terminals labelled TEMPERATURE SENSOR. See Figure 8.

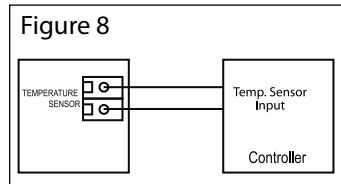
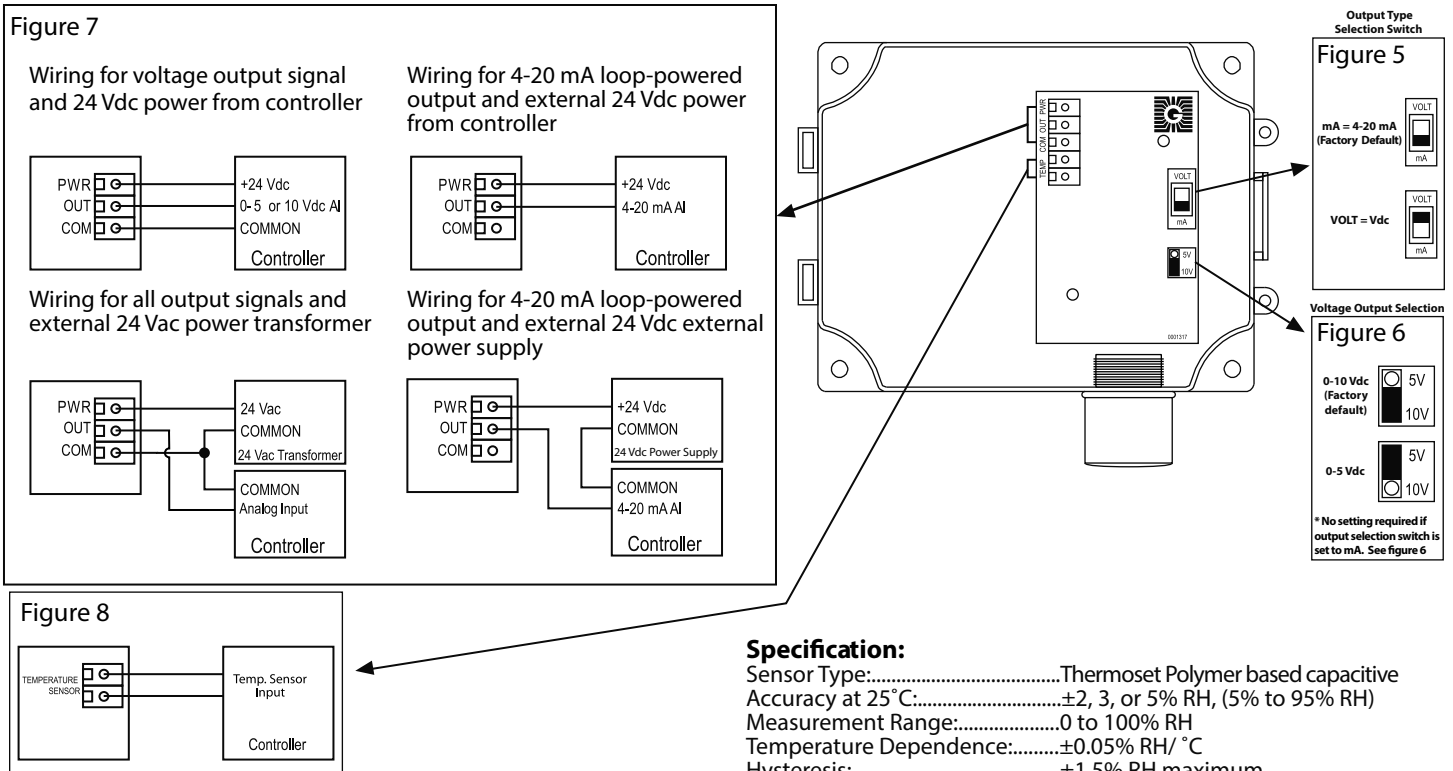

Dimensions:

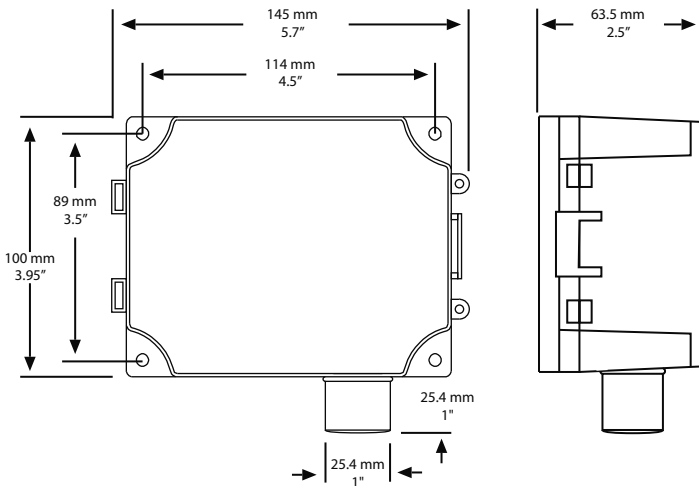

Specification:

Sensor Type:	Thermoset Polymer based capacitive
Accuracy at 25°C:	±2, 3, or 5% RH, (5% to 95% RH)
Measurement Range:	0 to 100% RH
Temperature Dependence:	±0.05% RH/ °C
Hysteresis:	±1.5% RH maximum
Repeatability:	±0.5% RH typical
Linearity:	±0.5% RH typical
Sensor Response Time:	15 seconds typical
Stability:	±1% RH typical at 50% RH in 5 yrs.
Operating Temperature:	-40° to 85°C (-40° to 185°F)
Operating Humidity:	0 to 95% RH non-condensing
Power Supply:	18 to 35 Vdc, 15 to 26 Vac
Consumption:	22 mA maximum
Input Voltage Effect:	Negligible over specified operating range
Protection Circuitry:	Reverse voltage protected and output limited
Output Signal:	4-20 mA current loop, 0-5 or 0-10 Vdc (selectable)
Output Drive at 24 Vdc:	550 ohms max for current output 10K ohms min for voltage output
Internal Adjustments:	Clearly marked ZERO and SPAN pots
Wiring Connections:	Screw terminal block (14 to 22 AWG)
Optional Temperature Sensor:	Various RTDs and thermistors available as two-wire resistance output
Enclosure:	ABS, IP65 (Nema 4X), 145 x 125.4 x 63.5mm (5.7" w x 4.95" h x 2.5" d)