

Specifications

Accuracy	+/- 2,3,5 % RH
Power Supply	24Vac/dc
Wiring Connections	Screw connectors (18-24 awg)
Output (scaled 0-100%)	4-20mA, 0-1, 0-5, 0-10 Vdc (jumper selectable)
Operating Temperature	0-70 °C (Space), -40-80 °C (Duct/OSA)

Relative Humidity Transmitter

The Relative Humidity transmitter uses a capacitive type humidity sensor and microprocessor temperature compensation for reliable, accurate readings.

Electrical Connection

Anti-static precautions should be followed to prevent damage to the device. The transmitter should be connected to the controller using 18 to 22 AWG wire and requires three wires for voltage and AC operation while only two wires are required for DC 4-20mA loop-powered operation. Use shielded cable for the highest noise immunity. Do not route signal wires in the same conduit with power cables as signal degradation may occur. The controller Analog Input (AI) must be selected to match the transmitter output before power is applied. The AI type must be a high impedance voltage input for use with 0-1, 0-5 or 0-10 Vdc transmitters, or a current input with 250 or 500 ohm impedance. Room transmitters have an operating range of 0 - 70 °C (32 - 158 °F) and the Duct and O.S.A. is -40 - 80 °C (-40 - 170 °F). The transmitter board should not be mounted where temperatures will exceed these values. See the connection diagram for more details.

If the unit is equipped with an optional temperature sensor (RTD or thermistor), the sensor output is available through the 'TEMP' terminals as a resistive signal.

Output Selection

Remove power to the transmitter before changing between voltage and current output signal types. Ensure the wiring is correct for the selected output signal type. Use caution when changing jumper positions as not to damage the circuit board, any components or the sensing elements.

The unit comes factory set for current output. To change the output signal to voltage, carefully remove the 3-position shorting jumper and replace it in the 'VOLTAGE' position. Place the two-position shorting jumper in the correct position for the required span (10 = 0 to 10 Vdc, 5 = 0 to 5 Vdc, 1 = 0 to 1 Vdc). NOTE: the voltage span jumper does not function when the output signal is set to 'CURRENT'.

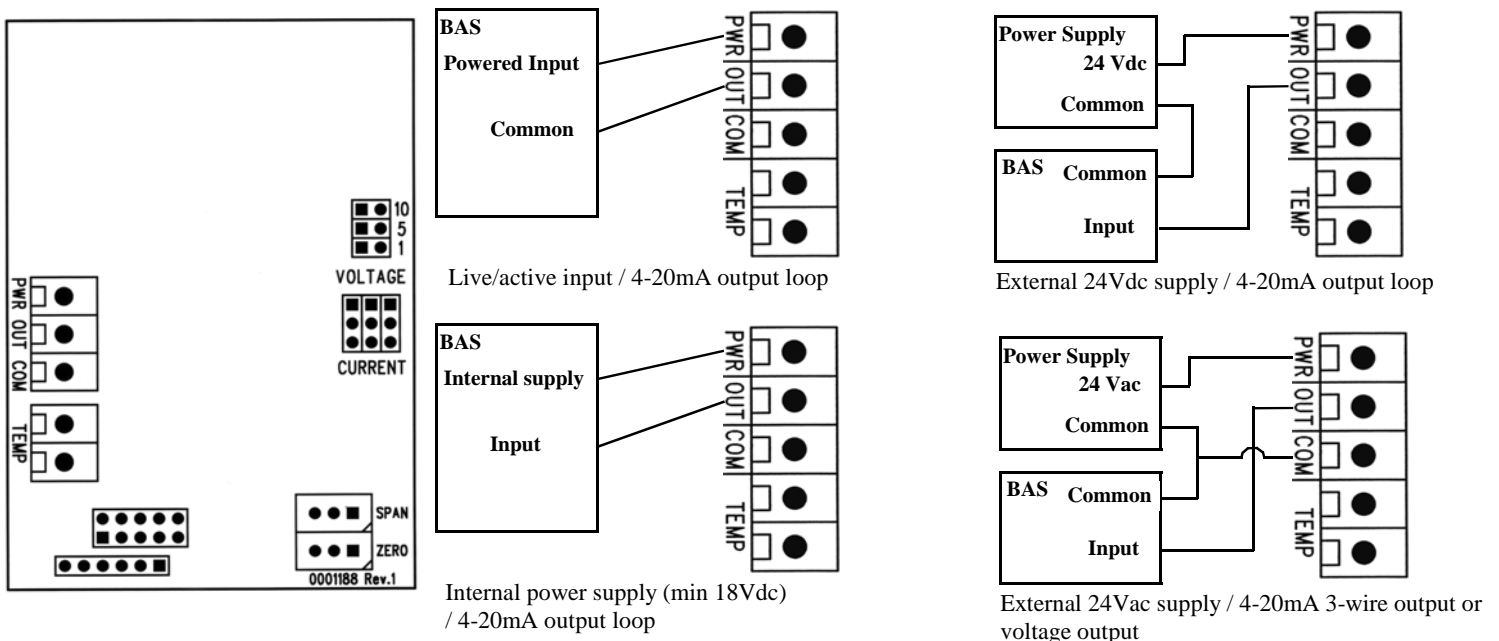

Mounting

Duct - Drill a 5/8" (or larger) hole in the return air duct. Remove the protective plastic sleeve from the probe and place it through the hole and secure the enclosure to the duct with sheetmetal screws. Orientation of the enclosure and probe will have no effect on the operation of the device.

Outside Air - For best results locate the sensor on the north side of the structure high under an eave to prevent incorrect readings from direct sunlight and damage due to the elements. Mount the OSA enclosure with the sensor module facing down to prevent the accumulation of dirt or water.